

OPERATOR'S MANUAL

INVERTER AC/DC PULSED TIG WELDER

TIG 320 AC/DC



2014. 06

IMPORTANT: Read this Owner's Manual Completely before attempting to use this equipment. Save this manual and keep it handy for quick reference. Pay particular attention to the safety instructions we have provided for your protection. Contact your distributor if you do not fully understand this manual.

CONTENT

§1 SAFETY	1
§1.1 SIGNAL EXPLANATION.....	1
§1.2 ARC WELDING DAMAGE	1
§1.3 THE KNOWLEDGE OF ELECTRIC AND MAGNETIC FIELDS	5
§2 SUMMARY	6
§ 2.1 BRIEF INTRODUCTION.....	6
§2.2 MODULE EXPLANATION	8
§2.3 WORKING PRINCIPLE.....	8
§2.4 VOLT-AMPERE CHARACTERISTIC	9
§3 INSTALLATION AND ADJUSTMENT.....	10
§3.1 PARAMETERS.....	10
3.2 DUTY CYCLE & OVER HEAT.....	11
§3.3 MOVEMENT AND PLACEMENT.....	11
§3.4 POWER SUPPLY INPUT CONNECTION.....	12
§3.5 POLARITY CONNECTION (MMA)	12
§3.6 ASSEMBLING THE EQUIPMENT (TIG)	13
§4 OPERATION	14
§4.1 LAYOUT FOR THE PANEL	14
§4.2 CONTROL PANEL.....	15
§4.3.1 PEDAL SWITCH CONTROL.....	19
§4.3.2 GUN SWITCH CONTROL CURRENT	19
§4.4 ARGON ARC WELDING OPERATION	20
§4.4.1 TIG WELDING (4T OPERATION)	20
§4.4.2 TIG WELDING (2T OPERATION).....	21
§4.5 WELDING PARAMETERS.....	23
§4.5.1 JOINT FORMS IN TIG/MMA	23
§4.5.2 THE EXPLANATION OF WELDING QUALITY	23
§4.5.3 TIG PARAMETERS MATCHING.....	23
§4.6 OPERATION ENVIRONMENT	26
§4.7 OPERATION NOTICES	27
§5 MAINTENANCE & TROUBLESHOOTING	28
§5.1 MAINTENANCE.....	28
§5.2 TROUBLESHOOTING.....	29
§5.3 ELECTRICAL PRINCIPLE DRAWING	32

§1 SAFETY

§1.1 Signal Explanation



• The above signals mean warning! Notice! Running parts and getting an electric shock or thermal parts will take damage for your body or others. The corresponding notices are as follows. It is quite a safe operation after taking several necessary protection measures.

§1.2 Arc Welding Damage

- The following signals and word explanations are to some damages for your body or others happening on the welding operation. While seeing these, please remind of yourself or others to be dangerous.
- Only ones who are trained professionally can install, debug, operate, maintain and repair the equipment.
- During the operation, non-concerned people should be lift, especially for children.
- After shut off the machine power, please maintain and examine the equipment according to §5 because of the DC voltage existing in the electrolytic capacitors.



ELECTRIC SHOCK CAN KILL.

- Never touch electrical parts.
- Wear dry, hole-free gloves and clothes to insulate yourself.
- Insulate yourself from work and ground using dry insulation. Make certain the insulation is large enough to cover your full area of physical contact with work and ground.
- Take carefully when using the equipment in small place, falling-off and wet circumstance.
- Never close the machine power before installation and adjustment.
- Ensure to install the equipment correctly and ground the work or metal to be welded to a good electrical (earth) ground according to the operation manual.
- The electrode and work (or ground) circuits are electrically “hot” when the welder is on. Do not touch these “hot” parts with your bare skin or wet clothing. Wear dry, hole-free gloves to insulate hands.
- In semiautomatic or automatic wire welding, the electrode, electrode reel, welding head, nozzle or

semiautomatic welding gun are also electrically “hot”.

- Always be sure the work cable makes a good electrical connection with the metal being welded. The connection should be as close as possible to the area being welded.
- Maintain the electrode holder, work clamp, welding cable and welding machine in good, safe operating condition. Replace damaged insulation.
- Never dip the electrode in water for cooling.
- Never simultaneously touch electrically “hot” parts of electrode holders connected to two welders because voltage between the two can be the total of the open circuit voltage of both welders.
- When working above floor level, use a safety belt to protect yourself from a fall should you get a shock.



FUMES AND GASES CAN BE DANGEROUS.

- Welding may produce fumes and gases hazardous to health. Avoid breathing these fumes and gases. When welding, keep your head out of the fume. Use enough ventilation and/or exhaust at the arc to keep fumes and gases away from the breathing zone. When welding with electrodes which require special ventilation such as stainless or hard facing or on lead or cadmium plated steel and other metals or coatings which produce highly toxic fumes, keep exposure as low as possible and below Threshold Limit Values using local exhaust or mechanical ventilation. In confined spaces or in some circumstances, outdoors, a respirator may be required. Additional precautions are also required when welding on galvanized steel.
- Do not weld in locations near chlorinated hydrocarbon vapors coming from degreasing, cleaning or spraying operations. The heat and rays of the arc can react with solvent vapors to form phosgene, a highly toxic gas, and other irritating products.
- Shielding gases used for arc welding can displace air and cause injury or death. Always use enough ventilation, especially in confined areas, to insure breathing air is safe.
- Read and understand the manufacturer’s instructions for this equipment and the consumables to be used, including the material safety data sheet and follow your employer’s safety practices.



ARC RAYS CAN BURN.

- Use a shield with the proper filter and cover plates to protect your eyes from sparks and the rays of the

arc when welding or observing open arc welding.

- Use suitable clothing made from durable flame-resistant material to protect your skin and that of your helpers from the arc rays.
- Protect other nearby personnel with suitable, non-flammable screening and /or warn them not to watch the arc nor expose themselves to the arc rays or to hot spatter or metal.



SELF-PROTECTION

- Keep all equipment safety guards, covers and devices in position and in good repair. Keep hands, hair, clothing and tools away from V-belts, gears, fans and all other moving parts when starting, operating or repairing equipment.
- Do not put your hands near the engine fan. Do not attempt to override the governor or idler by pushing on the throttle control rods while the engine is running.



DO NOT add the fuel near an open flame welding arc or when the engine is running. Stop the engine and allow it to cool before refueling to prevent spilled fuel from vaporizing on contact with hot engine parts and igniting. Do not spill fuel when filling tank. If fuel is spilled, wipe it up and do not start engine until fumes have been eliminated.



WELDING SPARKS can cause fire or explosion.

- Remove fire hazards from the welding area. If this is not possible, cover them to prevent the welding sparks from starting a fire. Remember that welding sparks and hot materials from welding can easily go through small cracks and openings to adjacent areas. Avoid welding near hydraulic lines. Have a fire extinguisher readily available.
- Where compressed gases are to be used at the job site, special precautions should be used to prevent hazardous situation.
- When not welding, make certain no part of the electrode circuit is touching the work or ground. Accidental contact can cause overheating and create a fire hazard.
- Do not heat, cut or weld tanks, drums or containers until the proper steps have been taken to insure that such procedures will not cause flammable or toxic vapors from substances inside. They can cause

an explosion even though they have been “cleaned”.

- Vent hollow castings or containers before heating, cutting or welding. They may explode.
- Sparks and spatter are thrown from the welding arc. Wear oil free protective garments such as leather gloves, heavy shirt, cuff less trousers, high shoes and a cap over your hair. Wear ear plugs when welding out of position or in confined places. Always wear safety glasses with side shields when in a welding area.
- Connect the work cable to the work as close to the welding area as practical. Work cables connected to the building framework or other locations away from the welding area increase the possibility of the welding current passing through lifting chains, crane cables or other alternate circuits. This can create fire hazards or overheat lifting chains or cables until they fail.



Rotating parts may be dangerous.

- Use only compressed gas cylinders containing the correct shielding gas for the process used and properly operating regulators designed for the gas and pressure used. All hoses, fittings, etc. should be suitable for the application and maintained in good condition.
- Always keep cylinders in an upright position securely chained to an undercarriage or fixed support.
- Cylinders should be located:
 - Away from areas where they may be struck or subjected to physical damage.
 - A safe distance from arc welding or cutting operations and any other source of heat, sparks, or flame.
- Never allow the electrode, electrode holder or any other electrically “hot” parts to touch a cylinder.
- Keep your head and face away from the cylinder valve outlet when opening the cylinder valve.
- Valve protection caps should always be in place and hand tight except when the cylinder is in use or connected for use.

§1.3 The knowledge of Electric and Magnetic Fields

Electric current flowing through any conductor causes localized Electric and Magnetic Fields (EMF). The discuss on the effect of EMF is ongoing all the world. Up to now, no material evidences show that EMF may have effects on health. However, the research on damage of EMF is still ongoing. Before any conclusion, we should minimize exposure to EMF as few as possible.

In order to minimize EMF, we should use the following procedures:

- Route the electrode and work cables together – Secure them with tape when possible.
- All cables should be put away and far from the operator.
- Never coil the power cable around your body.
- Make sure welding machine and power cable to be far away from the operator as far as possible according to the actual circumstance.
- Connect the work cable to the workpiece as close as possible to the area being welded.
- The people with heart-pacemaker should be away from the welding area.

§2 SUMMARY

§ 2.1 Brief Introduction

TIG 320 400 AC/DC welding machine adopts the latest pulse width modulation (PWM) technology and insulated gate bipolar transistor (IGBT) power module, which can change work frequency to medium frequency so as to replace the traditional hulking work frequency transformer with the cabinet medium frequency transformer. Thus, it is characterized with portable, small size, light weight, low consumption and etc.

The parameters of TIG 320 400 AC/DC on the front panel all can be adjusted continuously and steplessly, such as start current, crater arc current, welding current, base current, duty ratio, upslope time, downslope time, pre-gas, post-gas, pulse frequency, AC frequency, balance, hot start, arc force and arc length etc. When welding, it takes high frequency and high voltage for arc igniting to ensure the success ratio of igniting arc.

TIG 320 400 AC/DC Characteristics:

- **MCU control system, responds immediately to any changes.**
- **High frequency and high voltage for arc igniting to ensure the success ratio of igniting arc, the reverse polarity ignition ensures good ignition behavior in TIG-AC welding.**
- **Avoid AC arc-break with special means, even if arc-break occurs the HF will keep the arc stable.**
- **Pedal control the welding current.**
- **TIG/DC operation, If the tungsten electrode touches the workpiece when welding, the current will drop to short-circuit current to protect tungsten.**
- **Intelligent protection: over-voltage, over-current, over-heat, when the problems listed before occurred, the alarm lamp on the front panel will be on and the output current will be cut off. It can self-protect and prolong the using life.**
- **Double purposes : AC inverter TIG/MMA and DC inverter TIG/MMA, Excellent performance on Al-alloy, carbon steel, stainless steel, titanium.**

According to choosing the front panel functions, the following six welding ways can be realized.

- DC MMA
- DC TIG

- DC Pulse TIG
- AC MMA
- AC TIG
- AC Pulse TIG

1.For DC MMA, polarity connection can be chosen according to different electrodes, please refer to §3.5;

2.For AC MMA, magnetic flow caused by invariable DC polarity can be avoided;

3.For DC TIG, DCEP is used normally (workpiece connected to positive polarity, while torch connected to negative polarity). This connection has many characters, such as stable welding arc, low tungsten pole loss, more welding current, narrow and deep weld;

4.For AC TIG (rectangle wave), arc is more stable than Sine AC TIG. At the same time, you can not only obtain the max penetration and the min tungsten pole loss, but also obtain better clearance effect.

5.DC Pulsed TIG has the following characters: 1) Pulse heating. Metal in Molten pool has short time on high temperature status and freezes quickly, which can reduce the possibility to produce hot crack of the materials with thermal sensitivity. 2) The workpiece gets little heat. Arc energy is focused. Be suitable for thin sheet and super thin sheet welding. 3) Exactly control heat input and the size of the molten pool. The depth of penetration is even. Be suitable for welding by one side and forming by two sides and all position welding for pipe. 4) High frequency arc can make metal for microlite fabric, eliminate blowhole and improve the mechanical performance of the joint. 5) High frequency arc is suitable for high welding speed to improve the productivity.

TIG 320 400 AC/DC-series welding machine is suitable for all positions welding for various plates made of stainless steel, carbon steel, alloyed steel, titanium, aluminium, magnesium, cuprum, etc, which is also applied to pipe installment, mould mend, petrochemical, architecture decoration, car repair, bicycle, handicraft and common manufacture.

MMA——Manual Metal Arc welding;

PWM——Pulse-Width Modulation;

IGBT—Insulation Gate Bipolar Transistor

TIG—Tungsten Insert Gas welding

§2.2 Module Explanation

The module explanation of arc welding machine must accord with the correlative prescripts of National Standard GB10249. It is explained as the following (take TIG 320 AC/DC PULSE as an example).

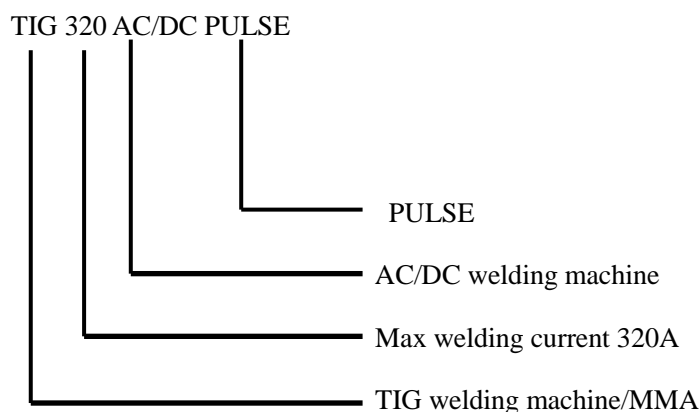

§2.3 Working Principle

The working principle of TIG 320 400 AC/DC welding machines is shown as the following figure. Three-phase 380V work frequency AC is rectified into DC (about 312V), then is converted to medium frequency AC (about 20KHz) by inverter device (IGBT module), after reducing voltage by medium transformer (the main transformer) and rectifying by medium frequency rectifier (fast recovery diodes), then is outputted DC or AC by selecting IGBT module. The circuit adopts current feedback control technology to insure current output stably. Meanwhile, the welding current parameter can be adjusted continuously and steplessly to meet with the requirements of welding craft.

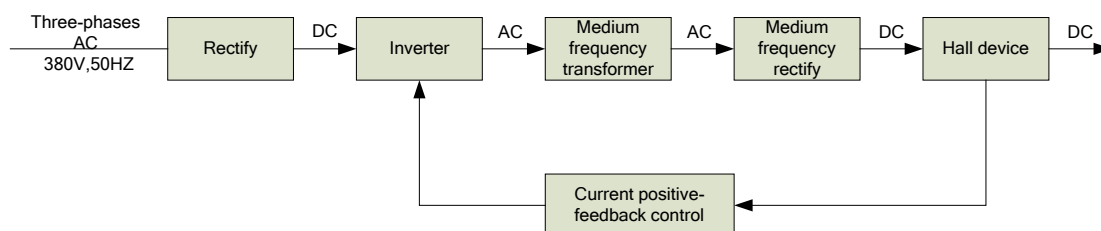

§2.4 Volt-Ampere Characteristic

TIG 320 400 AC/DC welding machine has an excellent volt-ampere characteristic, whose graph is shown as the following figure. The relation between the conventional rated loading voltage U_2 and the conventional welding current I_2 is as follows:

When $I_2 \leq 600\text{A}$, $U_2 = 10 + 0.04I_2(\text{V})$; When $I_2 > 600\text{A}$, $U_2 = 34(\text{V})$.

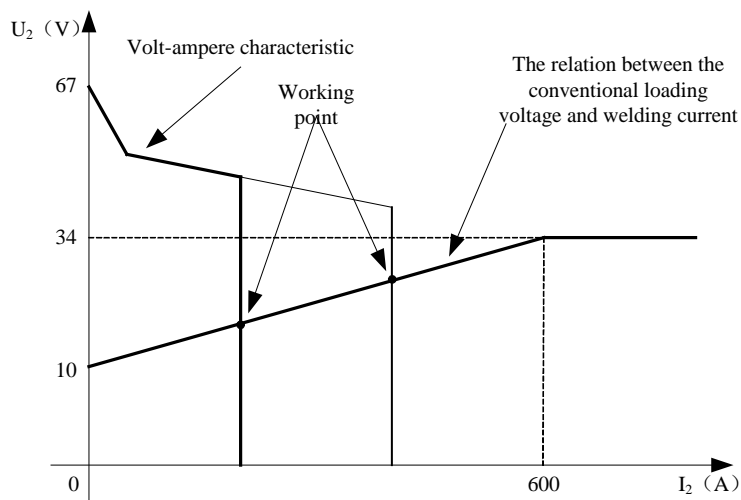

§3 Installation and Adjustment

§3.1 Parameters

Models Parameters	TIG 320 AC/DC PULSE		TIG 400 AC/DC PULSE	
Input power	3-380±10%, 50/60Hz		3-380±10%, 50/60Hz	
Rated input current (A)	21 (TIG)	27.5 (MMA)	26.5 (TIG)	36.5 (MMA)
Rated input power (KW)	9.5 (TIG)	13 (MMA)	13 (TIG)	17.4 (MMA)
Power factor	0.65		0.70	
no-load voltage(V)	61		67	
Adjustment range of start current (A)	10~welding current		10~welding current	
Adjustment range of welding current (A)	10-320		10-400	
Adjustment range of downslope time (S)	0~10		0~10	
Pre-gas time (S)	0~2		0~2	
Adjustment range of post-gas time (S)	0~10		0~10	
Clearance effect (%)	5-95		5-95	
Efficiency	≥85		≥85	
Duty cycle (40°C, 10 minutes)	60% 320A		60% 400A	
	100% 250A		100% 310A	
Protection class	IP23		IP23	
Insulation class	H		H	
Dimensions of Machine (L×W×H) (mm)	550×240×445		550×240×445	
Weight(Kg)	25.5		27	

3.2 Duty cycle & Over heat

The letter “X” stands for duty cycle, which is defined as the proportion of the time that a machine can work continuously within a certain time (10 minutes). The rated duty cycle means the proportion of the time that a machine can work continuously within 10 minutes when it outputs the rated welding current.

The relation between the duty cycle “X” and the output welding current “I” is shown as the right figure.

If the welder is over-heat, the IGBT over-heat protection unit inside it will output an instruction to cut output welding current, and brighten the over-heat pilot lamp on the front panel. At this time, the machine should be relaxed for 15 minutes to cool the fan. When

operating the machine again, the welding output current or the duty cycle should be reduced.

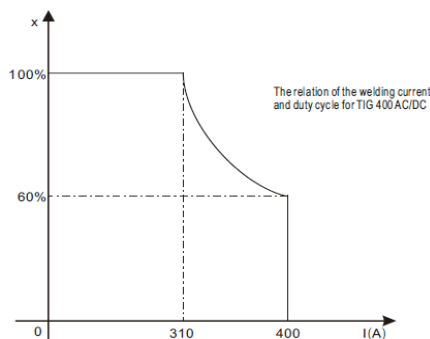
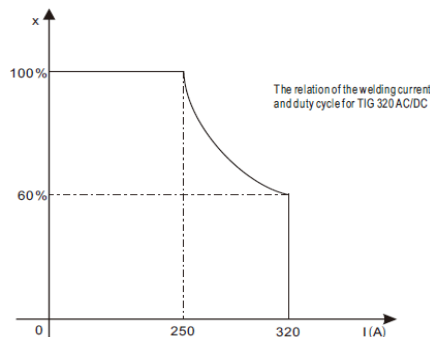

§3.3 Movement and placement

Please take care for the welder when moving it, and do not make it sloped.

It also can be moved by the handle on the top of the welder. Place the welder well when moving it to the right position. When the machine gets to the destination, it needs to be fixed up to avoid gliding.

When using forklift, its arm length must be long enough to reach the outside so as to ensure lifting safely.

The movement may result in the potential danger or substantive hazard, so please make sure that the machine is on the safe position before using it.

§3.4 Power supply input connection

TIG 320 400 AC/DC welding machines' power supply connects to 380V.

When the power supply voltage is over the safe work voltage, there are over voltage and under voltage protection inside the welder, the alarm light will on, at the same time, the current output will be cut off.

If the power supply voltage continually goes beyond the safe work voltage range, it will shorten the welder life-span. The below measures can be used:

- Change the power supply input net. Such as, connect the welder with the stable power supply voltage of distributor;
- Induce the machines using power supply in the same time;
- Set the voltage stabilization device in the front of power cable input.

§3.5 Polarity Connection (MMA)

MMA (DC): Choosing the connection of DCEN or DCEP according to the different electrodes.

Please refer to the electrode manual.

MMA (AC): No requirements for polarity connection.

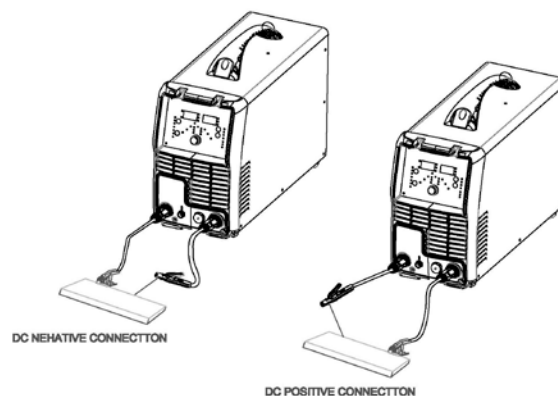

§3.6 Assembling the equipment (TIG)

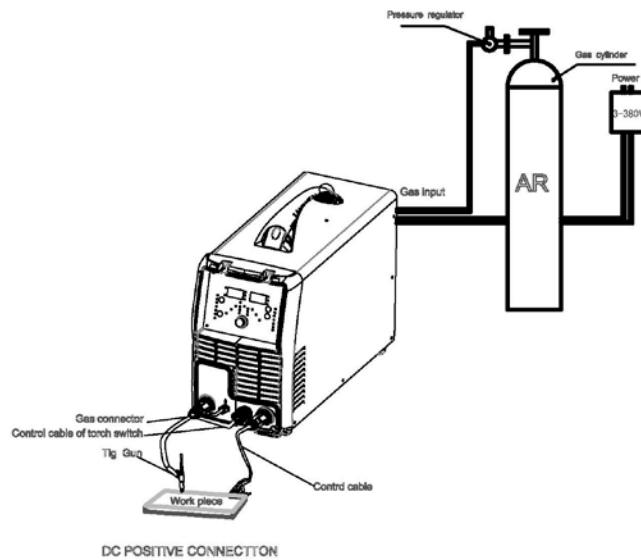

- Workpiece is connected to the positive electrode of welding machine, and welding torch is connected to the negative electrode, which is called DC POSITIVE CONNECTION; otherwise, that is called DC NEGATIVE CONNECTION. Generally, it is usually operated in DC POSITIVE CONNECTION in TIG welding mode.
- The control cable of torch switch consists of 2 wires, pedal control of 3 wires and the aero socket has 14 leads.
- Consumable parts for TIG torch, such as tungsten electrode, tip, gas nozzle, electrode shield(short/long) , please enquire us by mail or phone according to the accessory codes.
- When TIG 320 400 AC/DC welding machines are operated in HF ignition method, the ignition spark can cause interferences in equipment near the welding machine. Be sure to take specially safety precautions or shielding measures.

§4 Operation

§4.1 Layout for the panel

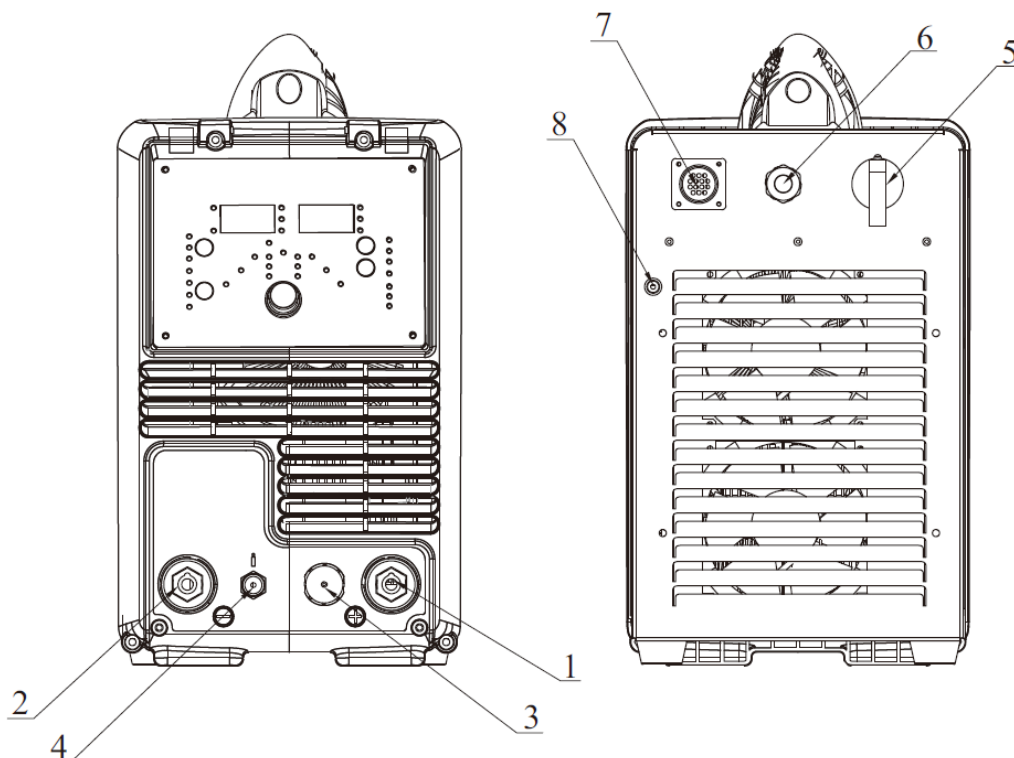

- 1 **Positive output:** The welder's positive polarity output.
- 2 **Negative output:** The welder's negative polarity output.
- 3 **Aero socket:** Is connected to torch switch control wire. (It has 14 leads and lead 8 - lead 9 are connected to torch switch control wire) .
- 4 **Shield gas connector:** Is connected to the gas input pipe of torch.
- 5 **Power source switch:** Switch to "ON", the welder is turned on, while switch to "OFF", the welder is turned off.
- 6 **Power source input:** To connect power source.
- 7 **water box connector:** To connect water box.
- 8 **Shield gas input joint:** To connect one head of the gas hose while the other head of which is connected to argon gas cylinder.

§4.2 Control panel

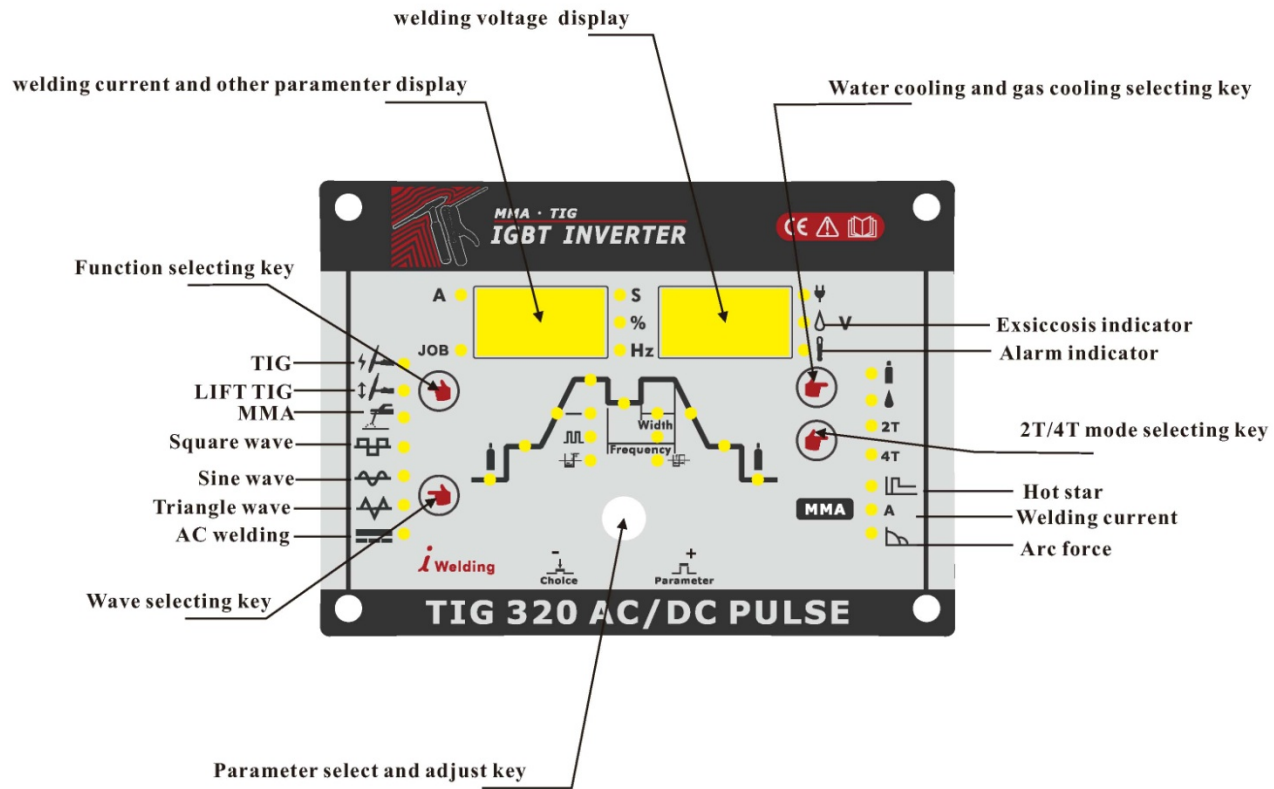

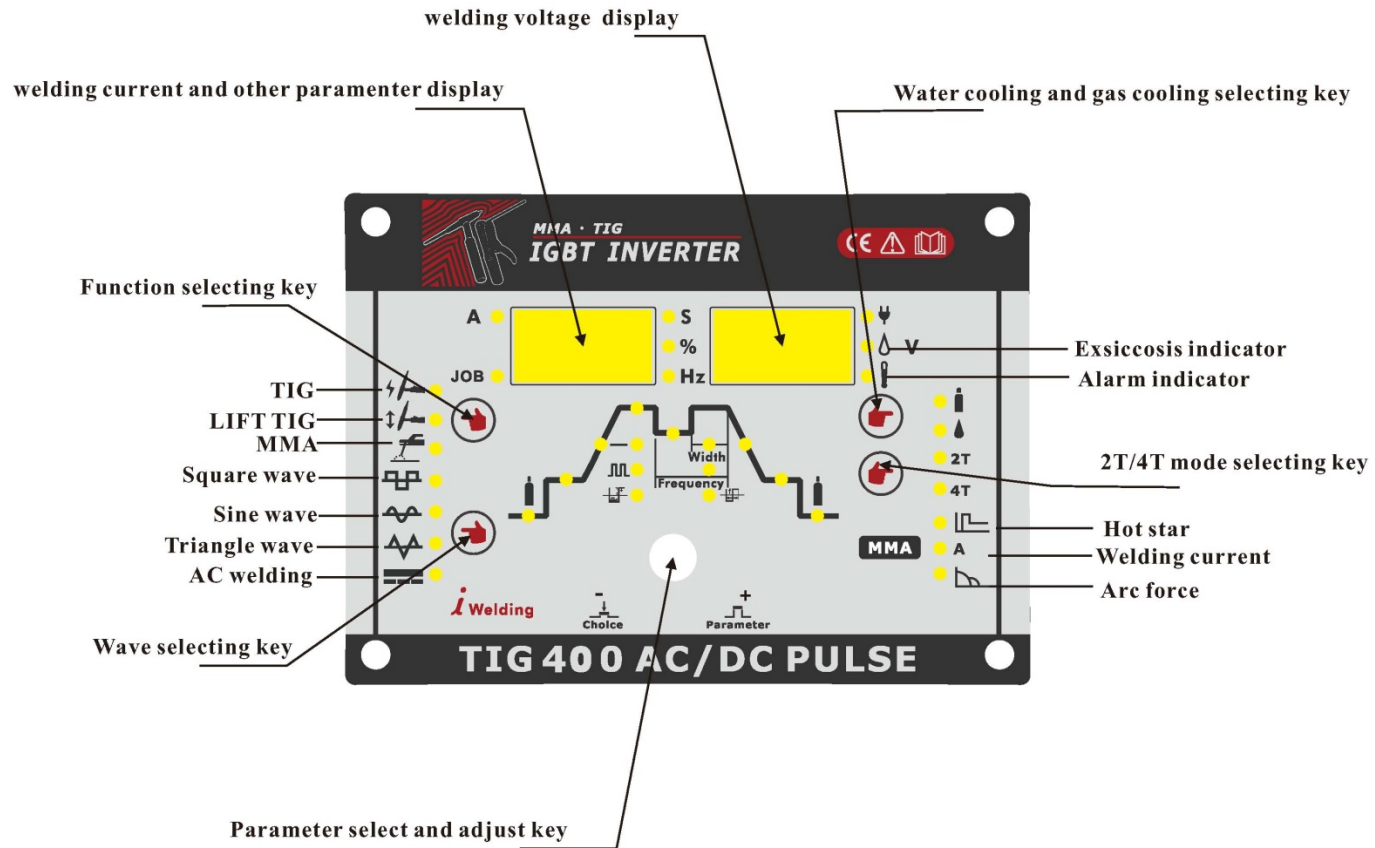

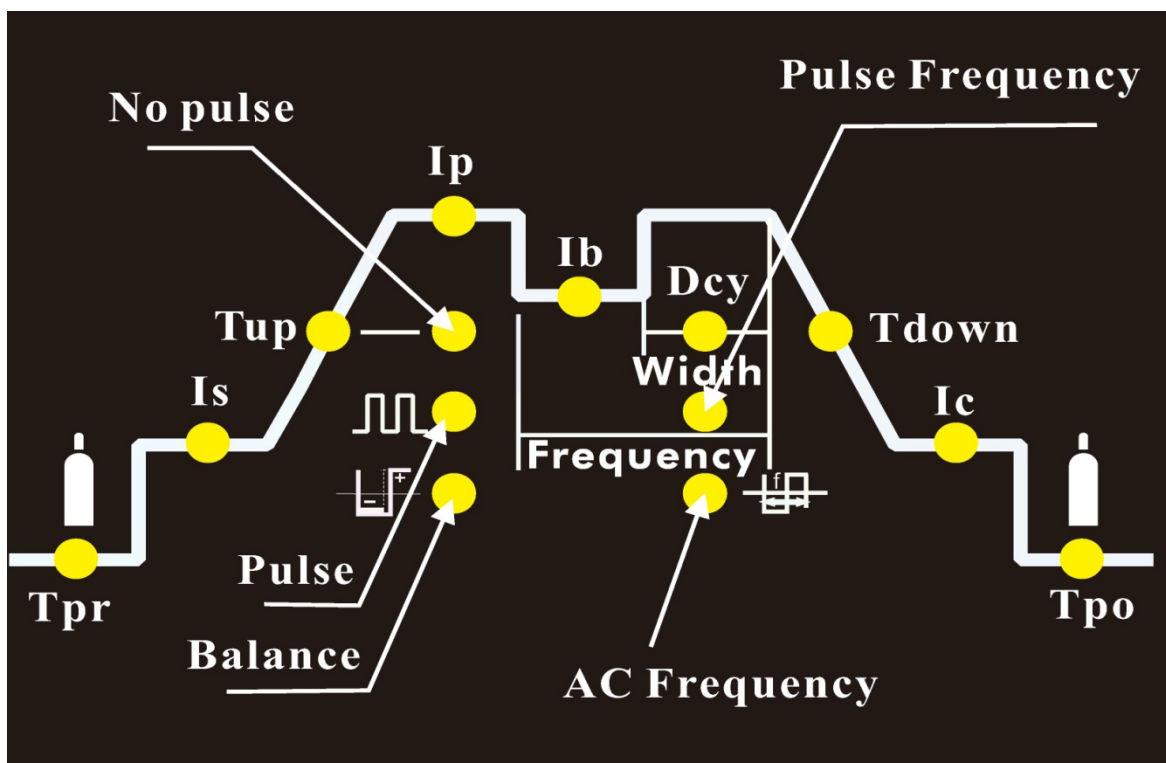

Available parameters where 2T and 4T mode have been selected:

Tpr Gas pre-flow time

Unit S
Setting range 0.0—2.0

Is Starting current (only with 4T)

Unit A
Setting range 10—320 (TIG 320); 10—400(TIG 400)

Tup Upslope time

Unit S
Setting range 0.0—10

Ip Welding current

Unit A
10—320 (TIG-320); 10—400 (TIG-400);

Ib Base current

Unit A
10—320 (TIG-320); 10—400 (TIG-400);

Dcy Ratio of pulse duration to base current duration

Unit %
Setting range 5—95

Fp Pulse frequency
 Unit Hz
 Setting range 0.5—200

Tdown Downslope time
 Unit S
 Setting range 0—10

Ic Crater arc current (only with 4T)
 Unit S
 Setting range 10-320 (TIG 320); 10-400 (TIG 400)

Tpo Gas post-flow time
 Unit S
 Setting range 0—10

AC frequency (only with TIG-AC)
 Unit Hz
 Setting range 50—250

Balance (only with TIG-AC)

Balance adjustment is mainly used to set the adjustment of eliminating metal-oxide (such as Aluminium, Magnesium and its alloy) while AC output.

Unit
 Setting range -5—+5

§4.3.1 Pedal switch control

- When plug the fourteen-lead aero-socket of pedal switch in it. Welder will identify the pedal switch, the welding current knob on the front panel will can't use, and only 2T can be selected.
- When use the adjustment knob of max-welding current beside the pedal ,can set the max-current you want.
- The eighth and ninth of the fourteen-lead aero-socket is gun switch; The first and second of the fourteen-lead aero-socket is short circuit; The third、fourth and fifth of the fourteen-lead aero-socket is pedal adjustable resistance.

Adjustment knob of welding current

Connected to the 12-lead aero socket on the front panel

Adjustment knob of max welding current



§4.3.2 Gun switch control current

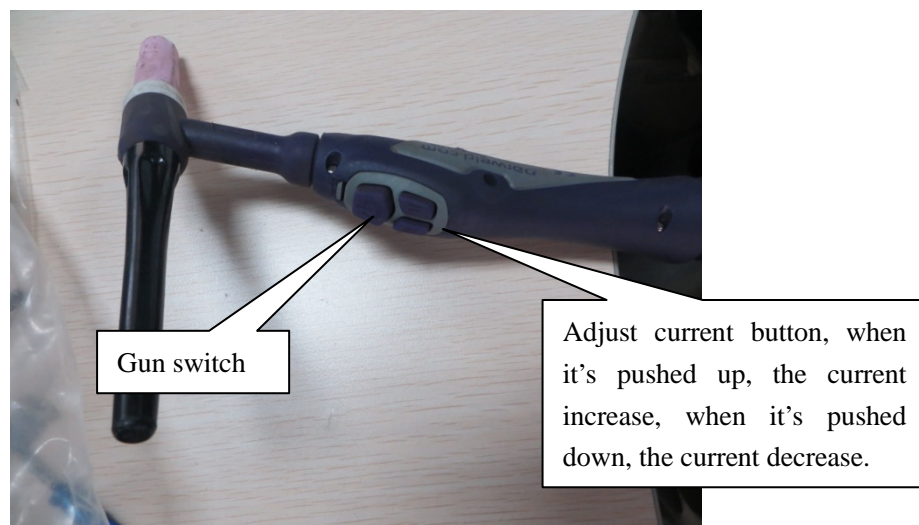

Gun switch

Adjust current button, when it's pushed up, the current increase, when it's pushed down, the current decrease.

§4.4 Argon Arc Welding Operation

§4.4.1 TIG welding (4T operation)

The start current and crater current can be pre-set. This function can compensate the possible crater that appears at the beginning and end of the welding. Thus, 4T is suitable for the welding of medium thickness plates.

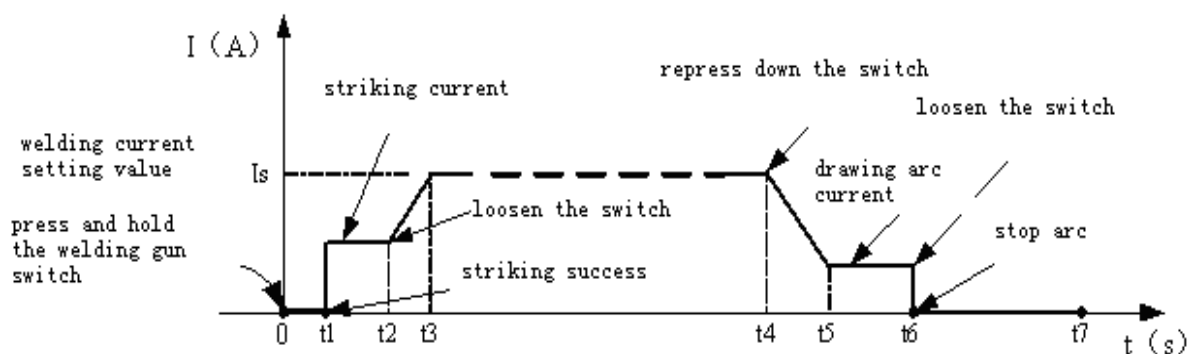

Introduction :

- 0: Press and hold the gun switch, Electromagnetic gas valve is turned on. The shielding gas starts to flow;
- 0~ t_1 : Pre-gas time (0.1~1S);
- t_1 ~ t_2 : Arc is ignited at t_1 and then output the setting value of start current;
- t_2 : Loosen the gun switch, the output current slopes up from the start current;
- t_2 ~ t_3 : The output current rises to the setting value (I_w or I_b), the upslope time can be adjusted;
- t_3 ~ t_4 : Welding process. During this period, the gun switch is loosen;

Note: Select the pulsed output, the base current and welding current will be outputted alternately; otherwise, output the setting value of welding current;

- t_4 : Press the torch switch again, the welding current will drop in accordance with the selected down-slope time.
- t_4 ~ t_5 : The output current slopes down to the crater current. The downslope time can be adjusted;
- t_5 ~ t_6 : The crater current time;
- t_6 : Loosen the gun switch, stop arc and keep on argon flowing;

- $t_6 \sim t_7$: Post-gas time can be set by the post-gas time adjustment knob on the front panel (0.1~10S) ;
- t_7 : Electromagnetic valve is closed and stop argon flowing. Welding is finished.

§4.4.2 TIG welding (2T operation)

This function without the adjustment of start current and crater current is suitable for the Re-tack welding, transient welding, thin plate welding and so on.

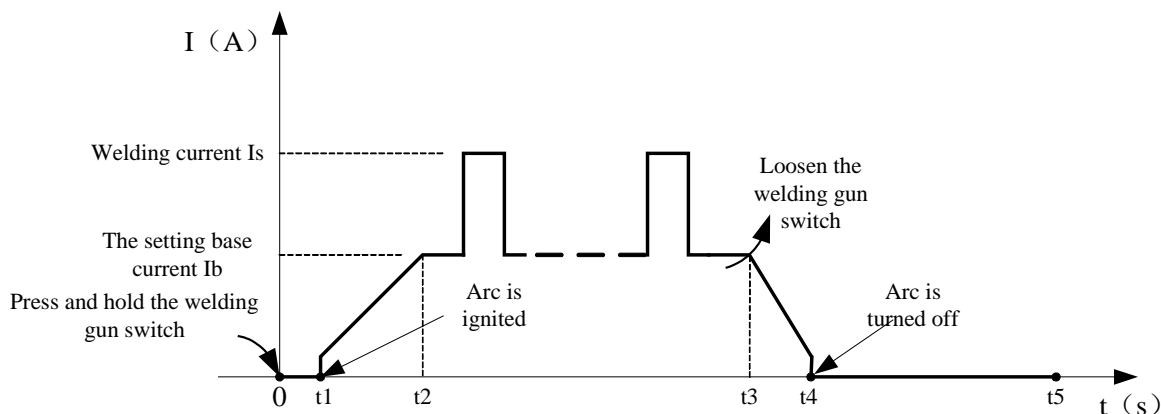

Introduction:

- 0: Press the gun switch and hold it. Electromagnetic gas valve is turned on. The shielding gas starts to flow.
- $0 \sim t_1$: Pre-gas time (0.1~1s)
- $t_1 \sim t_2$: Arc is ignited and the output current rises to the setting welding current (I_w or I_b) from the min welding current.
- $t_2 \sim t_3$: During the whole welding process, the gun switch is pressed and held without releasing.

Note: Select the pulsed output, the base current and welding current will be outputted alternately; otherwise, output the setting value of welding current;

- t_3 : Release the gun switch, the welding current will drop in accordance with the selected down-slope time.
- $t_3 \sim t_4$: The current drops to the minimum welding current from the setting current (I_w or I_b), and then arc is turned off.
- $t_4 \sim t_5$: Post-gas time, after the arc is turned off. You can adjust it (0.1~10s) through turning the knob on the front panel.

- t5: electromagnetic gas valve turned off, the shield gas stops to flow, and welding is finished.

Short circuit protect function:

① TIG /DC/LIFT: If the tungsten electrode touches the workpiece when welding, the current will drop to 20A, which can reduce the tungsten spoilage farthestly, prolong the using life of the tungsten electrode, and prevent tungsten clipping.

② TIG /DC/HF: If the tungsten electrode touches the workpiece when welding, the current will drop to 0 within 1s, which can reduce the tungsten spoilage farthestly, prolong the using life of the tungsten electrode, and prevent tungsten clipping.

③MMA operation: if the electrode touches workpiece over two seconds, the welding current will drop to the 0 automatically to protect the electrode.

Prevent arc-break function: TIG operation, Avoid arc-break with special means, even if arc-break occurs the HF will keep the arc stable

④TIG: If the TIG torch is pressed quickly, the welding current will drop a half, then if the TIG torch is pressed quickly again, the welding current will get back.

Notices:

- Check the condition of welding and connection units firstly, otherwise there will be malfunction such as ignition spark、 gas leakage、 out of control and so on.
- Check that whether there is enough Argon gas in the shield gas cylinder, you can test the electromagnetic gas valve through the switch on the front panel.
- Do not let the torch aim at your hand or else of your body. When you press the torch switch, the arc is ignited with a high-frequency, high-voltage spark, and the ignition spark can cause interferences in equipment.
- The flow rate is set according to the welding power used in the job. Turn the regulation screw to adjust the gas flow which is shown on the gas hose pressure meter or the gas bottle pressure meter.
- The spark ignition works better if you keep the 3mm distance from the workpiece to the tungsten electrode during the ignition.

Note: When select AC output, the current and the wave form are as same as the above, but output polarity changes alternately.

§4.5 Welding Parameters

§4.5.1 Joint forms in TIG/MMA

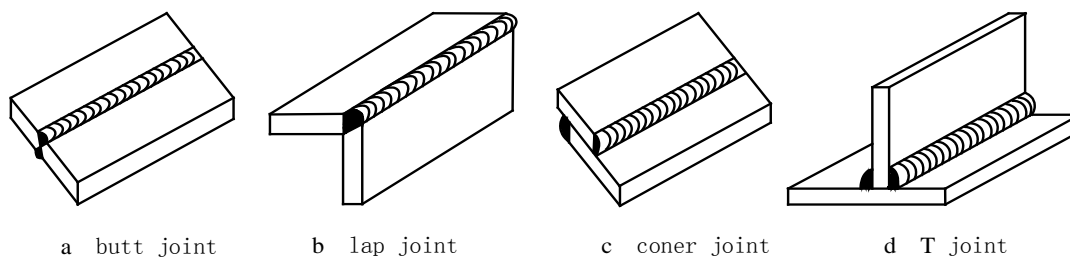

§4.5.2 The explanation of welding quality

The relation of welding area color & protect effect of stainless steel

Welding area color	argent , golden	blue	red-grey	grey	black
Protect effect	best	better	good	bad	worst

The relation of welding area color & protect effect of Ti-alloy

Welding area color	bright argent	orange-yellow	blue-purple	caesious	white powder of titanium oxid
Protect effect	best	better	good	bad	worst

§4.5.3 TIG Parameters Matching

The corresponding relationship between gas nozzle diameter and electrode diameter

Gas nozzle diameter/mm	Electrode diameter/mm
6.4	0.5
8	1.0
9.5	1.6 or 2.4
11.1	3.2
Notice: the above parameters originate from 《Welding Dictionary》 P142, Volume 1 of Edition 2.	

Gas nozzle and the shield gas flow rate

Welding current range/A	DC positive connection		AC	
	Gas nozzle diameter/mm	Gas flow rate/L · min ⁻¹	Gas nozzle diameter/mm	Gas flow rate/L · min ⁻¹
10~100	4~9.5	4~5	8~9.5	6~8
101~150	4~9.5	4~7	9.5~11	7~10
151~200	6~13	6~8	11~13	7~10
201~300	8~13	8~9	13~16	8~15

Notice: the above parameters originate from 《Welding Dictionary》 P149, Volume 1 of Edition 2.

tungsten electrode diameter /mm	sharpened of the electrode diameter/mm	angle of cone (°)	background current/A
1.0	0.125	12	2~15
1.0	0.25	20	5~30
1.6	0.5	25	8~50
1.6	0.8	30	10~70
2.4	0.8	35	12~90
2.4	1.1	45	15~150
3.2	1.1	60	20~200

TIG of stainless steel (single run welding)

Workpiece thickness /mm	Joint form	tungsten electrode diameter/mm	welding wire diameter/mm	Argon gas flow rate/ L · min ⁻¹	welding current (DCEP)	Welding speed/ cm · min ⁻¹
0.8	Butt joint	1.0	1.6	5	20~50	66
1.0	Butt joint	1.6	1.6	5	50~80	56
1.5	Butt joint	1.6	1.6	7	65~105	30
1.5	Corner joint	1.6	1.6	7	75~125	25
2.4	Butt joint	1.6	2.4	7	85~125	30
2.4	Corner joint	1.6	2.4	7	95~135	25
3.2	Butt joint	1.6	2.4	7	100~135	30
3.2	Corner joint	1.6	2.4	7	115~145	25
4.8	Butt joint	2.4	3.2	8	150~225	25
4.8	Corner joint	3.2	3.2	9	175~250	20

Notice: the above parameters originate from 《Welding Dictionary》 P150, Volume 1 of Edition 2.

Parameters of piping back sealing welding for mild steel (DCEP)

Piping diameter Φ/mm	Tungsten electrode diameter/mm	Gas nozzle diameter/mm	Welding wire diameter/mm	Welding current/A	Arc voltage/V	Argon flow rate / L • min ⁻¹	Welding rate / cm • min ⁻¹
38	2.0	8	2	75~90	11~13	6~8	4~5
42	2.0	8	2	75~95	11~13	6~8	4~5
60	2.0	8	2	75~100	11~13	7~9	4~5
76	2.5	8~10	2.5	80~105	14~16	8~10	4~5
108	2.5	8~10	2.5	90~110	14~16	9~11	5~6
133	2.5	8~10	2.5	90~115	14~16	10~12	5~6
159	2.5	8~10	2.5	95~120	14~16	11~13	5~6
219	2.5	8~10	2.5	100~120	14~16	12~14	5~6
273	2.5	8~10	2.5	110~125	14~16	12~14	5~6
325	2.5	8~10	2.5	120~140	14~16	12~14	5~6

Notice: the above parameters originate from 《Welding Dictionary》 P167, Volume 1 of Edition 2.

Parameters of AC TIG (MMA) for Aluminum and its alloy

Sheet thickness /mm	Welding wire diameter /mm	Tungsten electrode diameter /mm	Pre-heat Temperature /°C	Welding current /A	Argon flow rate / L • min ⁻¹	Gas nozzle diameter /mm	Remark
1	1.6	2	—	45~60	7~9	8	Flange welding
1.5	1.6~2.0	2	—	50~80	7~9	8	Flange or butt welding by one side
2	2~2.5	2~3	—	90~120	8~12	8~12	Butt welding
3	2~3	3	—	150~180	8~12	8~12	V-groove butt welding
4	3	4	—	180~200	10~15	8~12	
5	3~4	4	—	180~240	10~15	10~12	
6	4	5	—	240~280	16~20	14~16	

8	4~5	5	100	260~ 320	16~20	14~16	
10	4~5	5	100~ 150	280~ 340	16~20	14~16	
12	4~5	5~6	150~ 200	300~ 360	18~22	16~20	
14	5~6	5~6	180~ 200	340~ 380	20~24	16~20	
16	5~6	6	200~ 220	340~ 380	20~24	16~20	
18	5~6	6	200~ 240	360~ 400	25~30	16~20	
20	5~6	6	200~ 260	360~ 400	25~30	20~22	
16~20	5~6	6	200~ 260	300~ 380	25~30	16~20	
22~25	5~6	6~7	200~ 260	360~ 400	30~35	20~22	

Notice: the above parameters originate from 《Welding Dictionary》 P538, Volume 2 of Edition 2.

§4.6 Operation Environment

- Height above sea level is below 1000m.
- Operation temperature range:-10⁰C~+40⁰C.
- Relative humidity is below 90 % (20⁰C).
- Preferably site the machine some angles above the floor level, the maximum angle does not exceed 15⁰.
- Protect the machine against heavy rain or in hot circumstance against direct sunshine.
- The content of dust, acid, corrosive gas in the surrounding air or substance can not exceed normal standard.
- Take care that there is sufficient ventilation during welding. There is at least 30cm free distance between the machine and wall.

§4.7 Operation Notices

- Read §1 carefully before attempting to use this equipment.
- Connect the ground wire with the machine directly, and refer to §3.5.
- In case closing the power switch, no-load voltage may be exported. Do not touch the output electrode with any part of your body.
- Before operation, no concerned people should be left. Do not watch the arc in unprotected eyes.
- Ensure good ventilation of the machine to improve duty ratio.
- Turn off the engine when the operation finished to economize energy source.
- When power switch shuts off protectively because of failure. Don't restart it until problem is resolved. Otherwise, the range of problem will be extended.

§5 Maintenance & Troubleshooting

§5.1 Maintenance

In order to guarantee that arc welding machine works high-efficiently and in safety, it must be maintained regularly. Let customers understand the maintenance methods and means of arc welding machine more , enable customers to carry on simple examination and safeguarding by oneself, try one's best to reduce the fault rate and repair times of arc welding machine, so as to lengthen service life of arc welding machine .Maintenance items in detail are in the following table.

- **Warning: For safety while maintaining the machine, please shut off the supply power and wait for 5 minutes, until capacity voltage already drop to safe voltage 36V!**

date	Maintenance item
Daily examination	<p>Observe that whether panel knob and switch in the front and at the back of arc welding machine are flexible and put correctly in place. If the knob has not been put correctly in place, please correct; If you can't correct or fix the knob , please replace immediately;</p> <p>If the switch is not flexible or it can't be put correctly in place, please replace immediately; Please get in touch with maintenance service department if there are no accessories.</p> <p>After turn-on power, watch/listen to that whether the arc welding machine has shaking, whistle calling or peculiar smell. If there is one of the above problems, find out the reason to get rid of; if you can't find out the reason, Please contact local this area agent or the branch company.</p> <p>Observe that whether the display value of LED is intact. If the display number is not intact, please replace the damaged LED. If it still doesn't work, please maintain or replace the display PCB.</p> <p>Observe that whether the min/max value on LED accords with the set value. If there is any difference and it has affected the normal welding craft, please adjust it.</p> <p>Check up that Whether fan is damaged and is normal to rotate or control. If the fan is damaged, please change immediately. If the fan does not rotate after the arc welding machine is overheated , observe that whether there is something blocked in the blade, if it is blocked, please get rid of ; If the fan does not rotate after getting rid of the above problems, you can poke the blade by the rotation direction of fan. If the fan rotates normally, the start capacity should be replaced ; If not, change the fan.</p> <p>Observe that whether the fast connector is loose or overheated. if the arc welding machine has the above problems, it should be fastened or changed.</p> <p>Observe that Whether the current output cable is damaged. If it is damaged, it should be wrapped up, insulated or changed.</p>

Monthly examination	<p>Using the dry compressed air to clear the inside of arc welding machine. Especially for clearing up the dusts on radiator, main voltage transformer, inductance, IGBT module, the fast recover diode and PCB, etc.</p> <p>Check up the bolt in arc welding machine, if it is loose, please screw down it. If it is skid, please replace. If it is rusty, please erase rust on bolt to ensure it works well.</p>
Quarter- yearly examination	<p>Whether the actual current accords with the displaying value. If they does not accord, they should be regulated. The actual current value can be measured by the adjusted plier-type ampere meter.</p>
Yearly examination	<p>Measure the insulating impedance among the main circuit, PCB and case, if it below $1M\Omega$, insulation is thought to be damaged and need to change , and need to change or strengthen insulation.</p>

§5.2 Troubleshooting

- Before arc welding machines are dispatched from the factory, they have already been debugged accurately. So forbid anyone who is not authorized by us to do any change to the equipment!
- Maintenance course must be operated carefully. If any wire becomes flexible or is misplaced, it maybe potential danger to user!
- Only professional maintenance personal who is authorized by us could overhaul the machine!
- Guarantee to shut off the arc welding machine's power before turn on the outline of the equipment!
- If there is any problem and has no the authorized professional maintenance personal, please contact local agent or the branch company!

If there are some simple troubles of TIG 320 400 AC/DC-series welding machine, you can consult the following overhauling chart:

S/N	Troubles		Reasons	Solution
1	Turn on the power source, and fan works, but the power pilot lamp is not on.		The power light damaged or connection is not good	Check and repair Pr7
			The transformer of power is broken	Repair or change the transformer
			Control PCB failures	Repair or change the control Pr4
2	Turn on the power source, and the power lamp is on, but fan doesn't work		There is something in the fan	Clear out
			The start capacitor of fan damaged	Change capacitor
			The fan motor damaged	Change fan
3	Turn on the power source, the power lamp is not on, and fan doesn't work		No power supply input	Check whether there is power supply
			The fuse inside the machine damaged	Change it (3A)
4	The number on the display is not intact.		The LED in the display is broken	Change the LED
5	The max and min value displayed doesn't accord with the set value.		The max value is not accordant (refer to §3.1)	Adjust potentiometer I _{min} on the power board.
			The min value is not accordant (refer to §3.1)	Adjust potentiometer I _{max} in the current meter.
6	No no-load voltage output (MMA)		The machine is damaged	Check the main circuit and the Pr4.
7	Arc can not be ignited (TIG)	There is spark on the HF igniting board.	The welding cable is not connected with the two output of the welder.	Connect the welding cable to the welder's output.
			The welding cable damaged.	Repair or change it.
			The earth cable connected unstably.	Check the earth cable.
			The welding cable is too long.	Use an appropriate welding cable.
			There is oil or dust on the workpiece.	Check and remove it.
			The distance between tungsten electrode and workpiece is too long.	Reduce the distance (about 3mm).
	There is not spark on the HF igniting board.	The HF igniting board does not work.	Repair or change Pr8	
		The distance between the discharger is too short.	Adjust this distance (about 0.7mm).	
		The malfunction of the welding gun switch.	Check the welding gun switch, control cable and aero socket.	
8	No gas flow (TIG)		Gas cylinder is close or gas pressure is low	Open or change the gas cylinder
			Something in the valve	Remove it

S/N	Troubles	Reasons		Solution
		Electromagnetic valve is damaged		Change it
9	Gas always flows	The gas-test on the front panel is on		The gas-test on the front panel is off
		Something in the valve		Remove it
		Electromagnetic valve is damaged		Change it
		The adjustment knob of pre-gas time on the front panel is damaged		Repair or change it
10	The welding current can not be adjusted	The welding current potentiometer on the front panel connection is not good or damaged		Repair or change the potentiometer
11	No AC output while selecting "AC"	The power PCB is in trouble.		Repair or change it.
		The AC drive PCB damaged.		Change it.
		The AC IGBT module damaged.		Change it.
12	The welding current displayed isn't accordant with the actual value.	The min value displayed isn't accordant with the actual value. (Please refer to § 3.1)		Adjust potentiometer Imin on the power board.
		The max value displayed isn't accordant with the actual value. (Please refer to § 3.1)		Adjust potentiometer Imax on the power board.
13	The penetration of molten pool is not enough.	The welding current is adjusted too low		Increase the welding current
		The arc is too long in the welding process		Use 2T operation
14	The alarm lamp on the front panel is on	Over heat protection	Two much welding current	Reduce the welding current output
			Working time too long	Reduce the duty cycle (work intermittently)
		Over-voltage protection	Power supply fluctuates	Using the stable power supply
		Low-voltage protection	Power supply fluctuates	Using the stable power supply
			Too many machines using power supply in the same time	Reduce the machines using power supply in the same time
Over-current protection	Unusual current in the main circuit	Check and repair the main circuit and drive Pr6		

§5.3 Electrical principle drawing

