

OPERATORS' MANUAL



MULTIMIG 355F/MULTIMIG 515F INVERTER Based Welding Machine

IMPORTANT: Read this Owner's Manual Completely before attempting to use this equipment. Save this manual and keep it handy for quick reference. Pay particular attention to the safety instructions we have provided for your protection. Contact your distributor if you do not fully understand this manual.

CONTENT

- §1 Safety.....**
- §1.1 Symbols Explanation.....
- §1.2 Machine Operating warnings!.....
- §1.3 EMC device classification
- §1.4 EMC measure.....
- §1.5 Warning label.....
- §2 Overview.....**
- §2.1 Features
- §2.2 Technical Data.....
- §2.3 Brief Introduction.....
- §2.4 Duty cycle and Over-heat.....
- §2.5 Working Principle.....
- §2.6 Volt-Ampere Characteristic.....
- §3 Panel Functions & Descriptions.....**
- §3.1 Machine Layout Description**
- §3.1.1 Front and rear panel layout of welding machine
- §3.1.2 Front and rear panel layout of wire feeder
- §3.1.3 Internal panel layout of wire feeder
- §3.1.4 Front and rear panel layout of water cooling.....
- §3.2 Front Panel Functions and Descriptions**
- §3.2.1 Front Panel Functions of wire feeder
- §3.2.2 Operating process of wire feeder.....
- §3.2.3 Implicit parameter adjustment (Fn).....
- §3.2.4 JOB mode.....
- §3.2.5 Synergic Function
- §3.2.6 MMA Function - Front Panel Description.....
- §3.2.7 TIG Function - Front Panel Description.....
- §3.2.8 MIG Function - Front Panel Description.....
- §4 Installation & Operation**
- §4.1 Installation & Operation for MMA Welding.....**
- §4.1.1 Set up installation for MMA Welding

§4.1.2 MMA Welding.....

§4.1.3 MMA Welding Fundamentals

§4.2 Installation & Operation for TIG Welding

§4.2.1 Set up installation for TIG Welding

§4.2.2 DC TIG Welding

§4.2.3 TIG Welding Fusion Technique.....

§4.2.4 Tungsten Electrodes

§4.2.5 Tungsten Preparation.....

§4.2.6 Gun switch control current.....

§4.2.7 Pedal switch control

§4.3 Installation & Operation for MIG Welding

§4.3.1 Set up installation for MIG Welding

§4.3.2 Wire Feed Roller Selection

§4.3.3 Wire Installation and Set Up Guide.....

§4.3.4 MIG Torch Liner Installation

§4.3.5 MIG Torch Liner Types and Information

§4.3.6 Torch & Wire Feed Set Up for Aluminium Wire.....

§4.3.7 Set up installation for Spool Gun

§4.3.8 MIG Welding.....

§4.3.9 MIG Torch /Spool Gun control

§4.4 Standard welding programs

§4.5 Welding parameters.....

§4.6 Operation environment.....

§4.7 Operation Notices

§5 Welding trouble shooting.....

§5.1 MIG welding trouble shooting.....

§5.2 MIG wire feed trouble shooting

§5.3 DC TIG welding trouble shooting

§5.4 MMA welding trouble shooting.....

§6 Maintenance & Troubleshooting

§6.1 Maintenance.....

§6.2 Troubleshooting

§6.3 List of error code

§6.4 Electrical schematic drawing.....

§1 Safety

Welding and cutting equipment can be dangerous to both the operator and people in or near the surrounding working area, if the equipment is not correctly operated. Equipment must only be used under the strict and comprehensive observance of all relevant safety regulations. Read and understand this instruction manual carefully before the installation and operation of this equipment.

§1.1 Symbols Explanation



- The above symbols mean warning!

Notice! Running parts, getting an electric shock or making contacts with thermal parts will cause damage to your body and others. The underline message is as follows:

Welding is quite a safe operation after taking several necessary protection measures!

§1.2 Machine Operating warnings!

- The following symbols and words explanations are for some damages to your body or others, which could happen during the welding operation. While seeing these symbols, please remind yourself and others to be careful.
- Only people who are trained professionally can install, debug, operate, maintain and repair the welding equipment covered with this Operator's Manual!
- During the welding operation, non-concerned people should NOT be around, especially children!
- After shutting off the machine power, please maintain and examine the equipment according to §7 because of the DC voltage existing in the electrolytic capacitors at the output of the power supply!

**ELECTRIC SHOCK CAN KILL.**

Touching live electrical parts can cause fatal shocks or severe burns. The electrode and work circuit is electrically live whenever the output is on. The input power circuit and internal machine circuits are also live when power is on. In Mig/Mag welding, the wire, drive rollers, wire feed housing, and all metal parts touching the welding wire are electrically live. Incorrectly installed or improperly grounded equipment is dangerous.

- Never touch live electrical parts.
- Wear dry, hole-free gloves and clothes to insulate your body.
- Be sure to install the equipment correctly and ground the work or metal to be welded to a good electrical (earth) ground according to the operation manual.
- The electrode and work (or ground) circuits are electrically “hot” when the machine is ON. Do not touch these “hot” parts with your bare skin or wet clothing. Wear dry, hole-free gloves to insulate hands.
- In semiautomatic or automatic wire welding, the electrode, electrode reel, welding head, nozzle or semiautomatic welding gun are also electrically “hot”.
- Insulate yourself from work and ground using dry insulation. Make certain the insulation is large enough to cover your full area of physical contact with work and ground.
- Be Careful when using the equipment in small places, falling-off and wet circumstance.
- Always be sure the work cable makes a good electrical connection with the metal being welded. The connection should be as close as possible to the area being welded.
- Maintain the electrode holder, work clamp, welding cable and welding machine in good, safe operating condition. Replace damaged insulation.
- Never dip the electrode in water for cooling.
- Never simultaneously touch electrically “hot” parts of electrode holders connected

to two welders because voltage between the two can be the total of the open circuit voltage of both welders.

- When working above the floor level, use a safety belt to protect yourself from a fall should you get an electric shock!



FUMES AND GASES CAN BE DANGEROUS.

Smoke and gas generated whilst welding or cutting can be harmful to people's health. Welding produces fumes and gases. Breathing these fumes and gases can be hazardous to your health.

- Do not breathe the smoke and gas generated whilst welding or cutting, keep your head out of the fumes. Use enough ventilation and/or exhaust at the arc to keep fumes and gases away from the breathing zone. When welding with electrodes which require special ventilation such as stainless or hard facing or on lead or cadmium plated steel and other metals or coatings which produce highly toxic fumes, keep exposure as low as possible and below the Threshold Limit Values using local exhaust or mechanical ventilation. In confined spaces or in some circumstances, outdoors, a respirator may be required. Additional precautions are also required when welding on galvanized steel.
- Do not weld in locations near chlorinated hydrocarbon vapors coming from degreasing, cleaning or spraying operations. The heat and rays of the arc can react with solvent vapors to form phosgene, a highly toxic gas, and other irritating products.
- Shielded gases used for arc welding can displace air and cause injury or death. Always use enough ventilation, especially in confined areas, to insure breathing air is safe.
- Read and understand the manufacturer's instructions for this equipment and the consumables to be used, including the material safety data sheet and follow your employer's safety practices.



ARC RAYS: Harmful to people's eyes and skin.

Arc rays from the welding process produce intense visible and invisible ultraviolet and infrared rays that can burn eyes and skin.

- Use a shield with the proper filter and cover plates to protect your eyes from sparks and the rays of the arc when welding or observing open arc welding.
- Use suitable clothing made from durable flame-resistant material to protect your skin and that of your coworkers from the arc rays.
- Protect other nearby personnel with suitable, non-flammable screening and /or warn them not to watch the arc nor expose themselves to the arc rays or to hot spatter or metal.



SELF-PROTECTION

- Keep all equipment safety guards, covers and devices in position and in good repair. Keep hands, hair, clothing and tools away from V-belts, gears, fans and all other moving parts when starting, operating or repairing equipment.
- Do not put your hands near the engine fan. Do not attempt to override the governor or idler by pushing on the throttle control rods while the engine is running.



DO NOT add any fuel near an open-flame welding arc or when the engine is running. Stop the engine and allow it to cool before refueling to prevent spilled fuel from vaporizing on contact with hot engine parts and igniting. Do not spill fuel when filling tank. If fuel is spilled, wipe it up and do not start engine until fumes have been eliminated.

**WELDING SPARKS can cause fire or explosion.**

Welding on closed containers, such as tanks, drums, or pipes, can cause them to explode. Flying sparks from the welding arc, hot work piece, and hot equipment can cause fires and burns. Accidental contact of electrode to metal objects can cause sparks, explosion, overheating, or fire. Check and be sure the area is safe before doing any welding

- Remove fire hazards material from the welding area. If this is not possible, cover them to prevent the welding sparks from starting a fire. Remember that welding sparks and hot materials from welding can easily go through small cracks and openings to adjacent areas. Avoid welding near hydraulic lines. Have a fire extinguisher readily available.
- Where compressed gases are to be used at the job site, special precautions should be used to prevent hazardous situation.
- When not welding, make certain no part of the electrode circuit is touching the work or ground. Accidental contact can cause overheating and create a fire hazard.
- Do not heat, cut or weld tanks, drums or containers until the proper steps have been taken to insure that such procedures will not cause flammable or toxic vapors from substances inside. They can cause an explosion even though they have been “cleaned”.
- Vent hollow castings or containers before heating, cutting or welding. They may explode.
- Sparks and spatter are thrown from the welding arc. Wear oil free protective garments such as leather gloves, heavy shirt, cuff less trousers, high shoes and a cap over your hair. Wear earplugs when welding out of position or in confined places. Always wear safety glasses with side shields when in a welding area.
- Connect the work cable to the work as close to the welding area as practical. Work cables connected to the building framework or other locations away from the welding area increase the possibility of the welding current passing through lifting

chains, crane cables or other alternate circuits. This can create fire hazards or overheat lifting chains or cables until they fail.



Rotating parts may be dangerous.

- Use only compressed gas cylinders containing the correct shielding gas for the process used and properly operating regulators designed for the gas and pressure used. All hoses, fittings, etc. should be suitable for the application and maintained in good condition.
- Always keep cylinders in an upright position securely chained to an undercarriage or fixed support.
- Cylinders should be located:
 - Away from areas where they may be struck or subjected to physical damage.
 - At a safe distance from arc welding or cutting operations and any other source of heat, sparks, or flame.
- Never allow the electrode, electrode holder or any other electrically “hot” parts to touch a gas cylinder.
- Keep your head and face away from the cylinder valve outlet when opening the cylinder valve.
- Valve protection caps should always be in place and hand tight except when the cylinder is in use or connected for use.



Gas Cylinders.

Shielding gas cylinders contain gas under high pressure. If damaged, a cylinder can explode. Because gas cylinders are normally part of the welding process, be sure to treat them carefully. CYLINDERS can explode if damaged.

- Protect gas cylinders from excessive heat, mechanical shocks, physical damage, slag, open flames sparks, and arcs.

- Insure cylinders are held secure and upright to prevent tipping or falling over.
- Never allow the welding electrode or earth clamp to touch the gas cylinder, do not drape welding cables over the cylinder.
- Never weld on a pressurised gas cylinder, it will explode and kill you.
- Open the cylinder valve slowly and turn your face away from the cylinder outlet valve and gas regulator.



Gas build up.

The build up of gas can causes a toxic environment, deplete the oxygen content in the air resulting in death or injury. Many gases use in welding are invisible and odourless.

- Shut off shielding gas supply when not in use.
- Always ventilate confine spaces or use approved air-supplied respirator.



Electric and Magnetic Fields.

Electric current flowing through any conductor causes localized Electric and Magnetic Fields (EMF). The discussion on the effect of EMF is ongoing in the entire world. Up to now, no material evidences show that EMF may have effects on health. However, the research on the effect of EMF is still ongoing. Before any conclusion, we should minimize exposure to EMF as few as possible.

In order to minimize EMF, we should use the following procedures:

- Route the electrode and work cables together – Secure them with tape when possible.
- All cables should be put away and far from the operator.
- Never coil the power cable around your body.
- Make sure welding machine and power cable to be far away from the operator as far as possible according to the actual circumstance.

- Connect the work cable to the workpiece as close as possible to the area being welded.
- The people with heart-pacemaker should be away from the welding area.



Noise can damage hearing.

Noise from some processes or equipment can damage hearing. You must protect your ears from loud noise to prevent permanent loss of hearing.

- To protect your hearing from loud noise, wear protective ear plugs and/or ear muffs. Protect others in the workplace.
- Noise levels should be measured to be sure the decibels (sound) do not exceed safe levels.



Hot parts.

Items being welded generate and hold high heat and can cause severe burns. Do not touch hot parts with bare hands. Allow a cooling period before working on the welding gun. Use insulated welding gloves and clothing to handle hot parts and prevent burns.

§1.3 EMC device classification

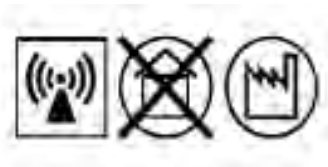

Radiation Class A Device.

- Only can be used in the industrial area
- If it is used in other area, it may cause connection and radiation problems of circuit.

Radiation Class B device.

- It can meet the radiation requirements of residential area and industrial area. It also can be used in residential area which power is supplied by public low voltage circuit.

EMC device can be classified by power nameplate or technical data.

hanker welding machines belong to Class A.

§1.4 EMC measure



In the special situation, The specified area may be affected, the standard of radiation limit value has been complied with (eg: The device, which is easy effected by electromagnetism, is used at the installation location, or there is radio or TV near the installation location). In this condition, the operator should adopt some appropriate measures to remove interference.

Accoring to the domestic and international standards, the ambient devices' electromagnetism situation and anti-interference ability must be checked:

- Safety device
- Power line, Signal transmission line and Date transmission line
- Date processing equipment and telecommunication equipment
- Inspection and calibration device

The effective measures avoid the problem of EMC:

a) Power source

Even though the power source connection meet rules, we still need to take additional measure to remove the electromagnetic interference. (eg: Use the right power filter.)

b) The welding line

- Try to shorten the length of cable
- Put the cable together
- Be Far away from other cable

c) Equipotential connection

d) Ground connection of work-piece

- When necessary, use appropriate capacitance to connect the ground.

e) Shielding, when necessary

- Shield the ambient devices

- Shield the whole welding machine

§1.5 Warning label

The device with a warning label. **Do not remove, destroy or cover this label.** These warnings are intended to avoid incorrect device operations that could result in serious personal injury or property damage.

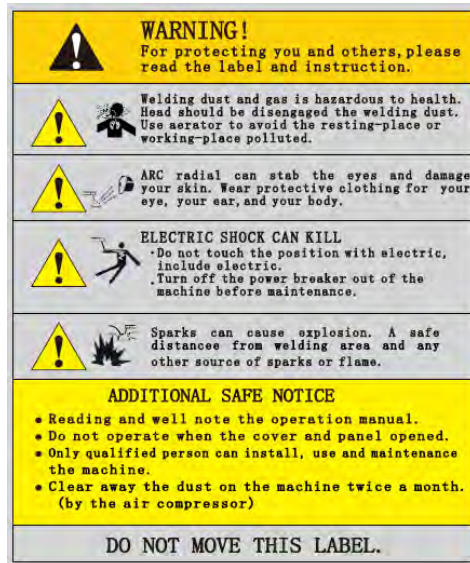

§2 Overview

§2.1 Features

- New PWM technology and IGBT inverter technology.
- MIG/MAG with Pulse SYN/Dual pulse SYN/Manual and SYN function
 - Synergic programs for aluminum, mill steel, stainless steel and CuSi
 - JOB mode (Save and call 100 different job records)
 - 2T /4T/S4T/Spot Weld welding mode
 - function parameter adjustment
- MMA function (Stick electrode)
 - VRD (Voltage Reduction Device)
 - Hot start (improves electrode starting)
 - Adjustable Arc Force
- DC TIG
 - Lift Arc ignition (prevents tungsten sticking during arc ignition)
 - 2T /4T Trigger Control
 - Adjustable Down slope
 - Gas/air cooling mode
- Internal wire feeder, gear driven for up to 300mm Ø spool
- Euro style MIG torch connection
- IP23 rating for environmental/safety protection
- Tolerant to variable power supply
- Spool Gun Connection

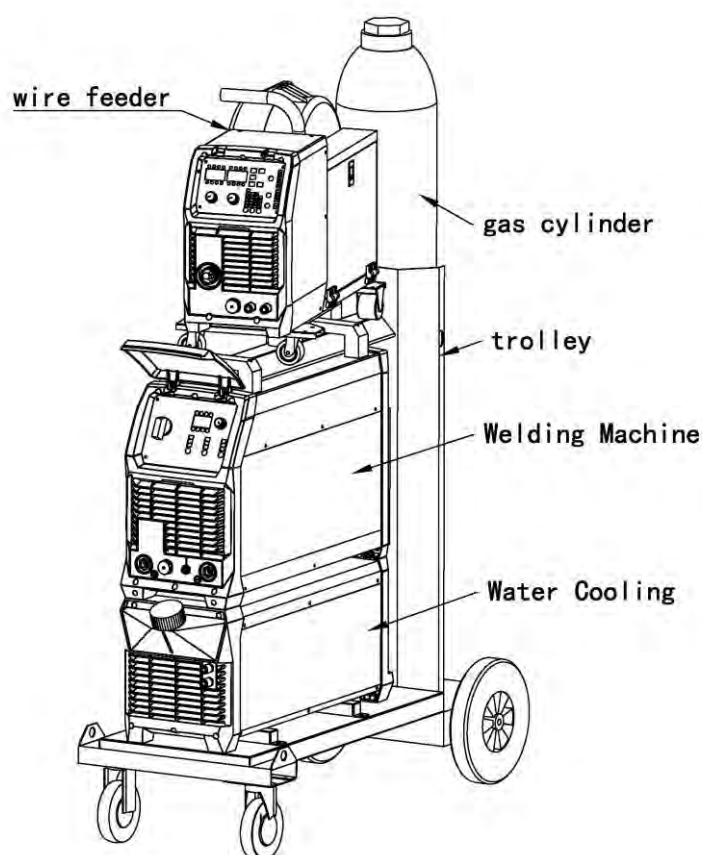

§2.2 Technical Data

Models Parameters	MULTIMIG 355F	MULTIMIG 515F
Input Voltage (V)	3~415±10%	3~415±10%
Frequency (HZ)	50/60	50/60
Input Current (A)	MIG 19 TIG 15 MMA 21	MIG 33 TIG 27.5 MMA 35
Input Power (KW)	MIG 12.8 TIG 10 MMA 14	MIG 21.5 TIG 18 MMA 23
Welding Current (A)	40-350(MIG)	40-500(MIG)
Welding Voltage (V)	10-35(MIG)	10-50(MIG)
No-load Voltage (V)	67	66
Duty cycle (40°C)	60%350A 100%275A	60%500A 100%400A
Diameter(mm)	Fe:0.6/0.9/1.0/1.2 Ss:0.8/0.9/1.0/1.2 Flux-Cored:0.6/0.8/0.9/1.0/1.2	Fe:0.6/0.9/1.0/1.2/1.6 Ss:0.8/0.9/1.0/1.2/1.6 Flux-Cored:0.6/0.8/0.9/1.0/1.6
Protection class	IP23	IP23
Insulation class	H	H
Dimensions (mm)	690*260*470	644*253*423
Weight (Kg)	21.5	30
Power Factor	0.7	0.7

Note: The above parameters are subject to change with future machine improvement!

§2.3 Brief Introduction

MULTI-GMAW series of welding machines is a new inverter-based MIG/MMA/TIG Welding machine with Synergic Programs and Dual pulse functions. The MIG function allows you to weld with Gas Shielded wire applications giving excellent, professional welding results. Easy step-less adjustment of voltage and wire feed coupled with integrated digital meters allows easy setting of welding parameters. **MULTI-GMAW** series of welding machines features MIG welding with Synergic welding programs designed for ease of use with your selected gas mixture. The operator selects the gas mixture and wire diameter they are using then simply start welding. Once this is done the operator can make fine adjustments to the voltage for even greater control of the weld pool. The added Lift-Arc DC TIG capability delivers perfect arc ignition every time and a remarkably smooth stable arc produces high quality TIG welds. TIG functionality includes adjustable Down Slope & Post Gas as well as being gas solenoid-valve equipped. The stick welding (MMA) capability delivers easy electrode welding with high quality results, including

cast Iron, stainless and low hydrogen. An additional feature is the Spool gun ready function that allows the simple connection of Spool Gun for the use of thin or softer wires that don't have the column strength to feed through MIG torches, such as aluminum wire. In the JOB mode, 100 different JOB records can be stored and called , improve the quality of welding process .

MULTI-GMAW series of arc welding machine is an industrial quality machine that is suitable for all positions welding for various plates made of stainless steel, carbon steel, alloyed steel etc. Applications applied to pipe installment, petrochemical, architecture equipment, car repair, bicycle repair, handicraft and common steel fabrication.

MULTI-GMAW series of welding machines has built-in automatic protection functions to protect the machines from over-voltage, over-current and over-heat. If any one of the above problems happens, the alarm lamp on the front panel will be lit and output current will be shut off automatically for the machine to protect itself and prolong the equipment using life.

§2.4 Duty cycle and Over-heat

The letter “X” stands for Duty Cycle, which is defined as the portion of the time a welding machine can weld continuously with it's rated output current within a certain time cycle (10 minutes).

The relation between the duty cycle “X” and the output welding current “I” is shown as the right figure.

If the welding machine is overheating, the IGBT over-heat protection sensing will send a signal to the welding machine control unit to cut the output welding current OFF and light the over-heat pilot lamp on the front panel. In that case, the machine should not be welding for 10-15 minutes to cool down with the fanrunning. When operating the machine again, the welding output current or the duty cycle should be reduced.

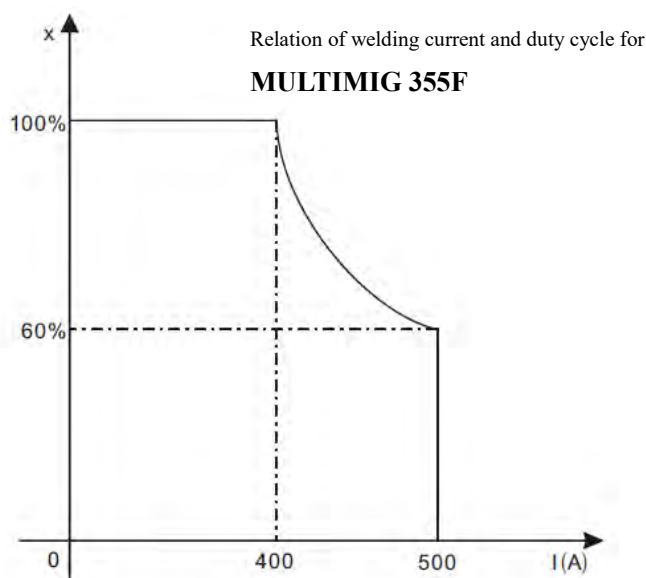

§2.5 Working Principle

The working principle of MULTI-GMAW series welding machine is shown as the following figure. Three-phase 380V work frequency AC is rectified into DC (530V), then is converted to medium frequency AC (about 20KHz) by inverter device (IGBT), after reducing voltage by medium transformer (the main transformer) and rectifying by medium frequency rectifier (fast recovery diodes), and is outputted by inductance filtering. The circuit adopts current feedback control technology to insure current output stably when MMA or TIG. And adopts voltage feedback control technology to insure voltage output stably when MIG. Meanwhile, the welding current parameter can be adjusted continuously and infinitely to meet with the requirements of welding craft.

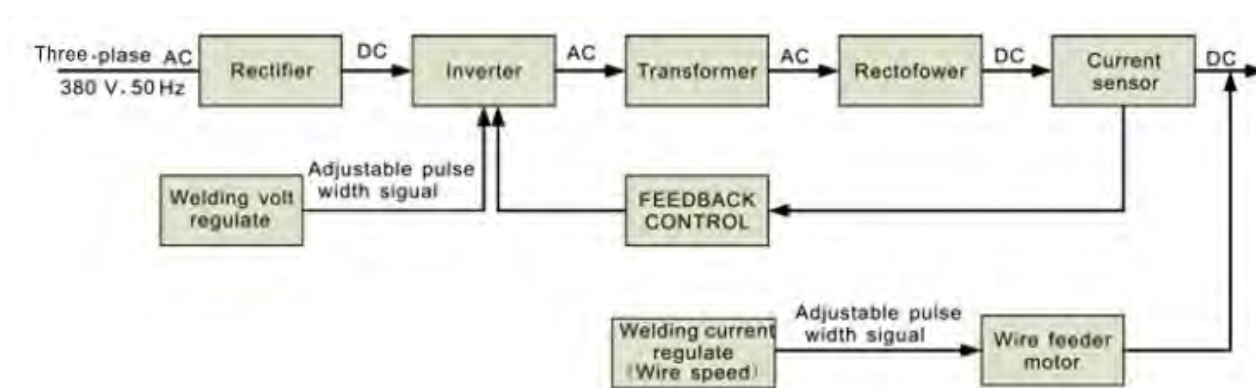

§2.6 Volt-Ampere Characteristic

MULTI-GMAW series of welding machines has an excellent volt-ampere characteristic, whose graph is shown as the following figure. The relation between the rated loading voltage U_2 and welding current I_2 is as follows: $U_2=14+0.05I_2(V)$

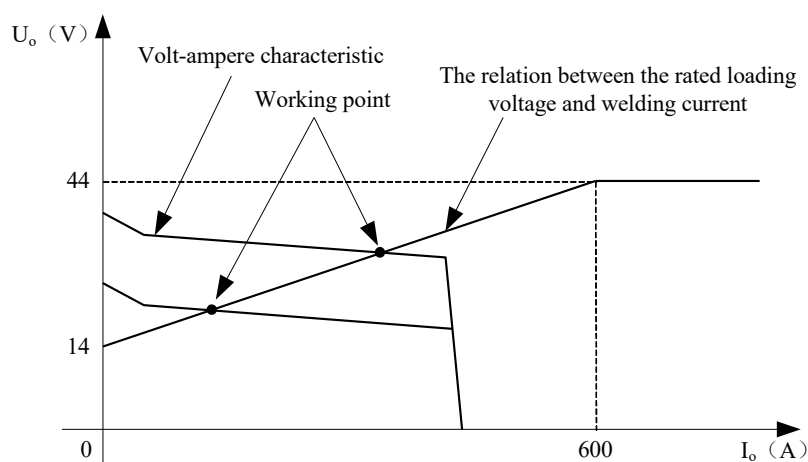

§3 Panel Functions & Descriptions

§3.1 Machine Layout Description

§3.1.1 Front and rear panel layout of welding machine

1. “-” Output terminal
2. Gas outlet
3. TIG gun control connector
4. “+” Output terminal
5. Gas Inlet
6. “+” Output terminal
7. The wire feeder control connector
8. The water cooling control connector
9. Input power cable
10. Power switch
11. Adjustment Knob
12. No water LED
13. Alarm Led
14. Power Led
15. The digital meter
16. 2T/4T Selector Switch
17. Gas/Air cooling mode Selector Switch
18. MIG/TIG/MMA/VRD MMA Selector Switch
19. Fan

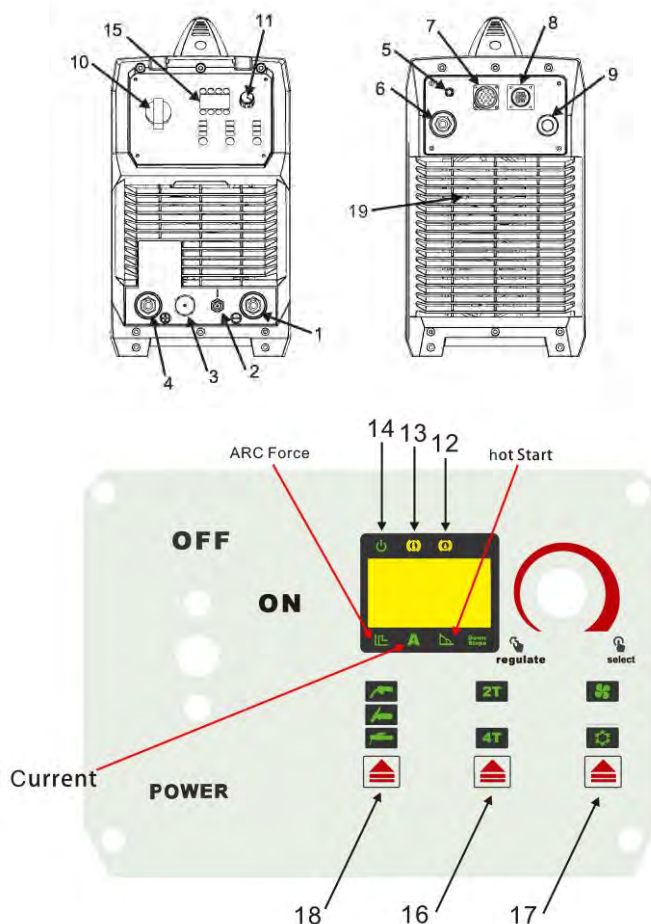

§3.1.2 Front and rear panel layout of

wire feeder

1. Mig Torch/Spool Gun Connector
2. Spool Gun Power Supply Connection
3. Water Inlet connector (blue)
4. Water outlet connector (red)
5. Gas Inlet
6. The wire feeder control connector
7. “+” input terminal
8. Water Inlet connector (blue)

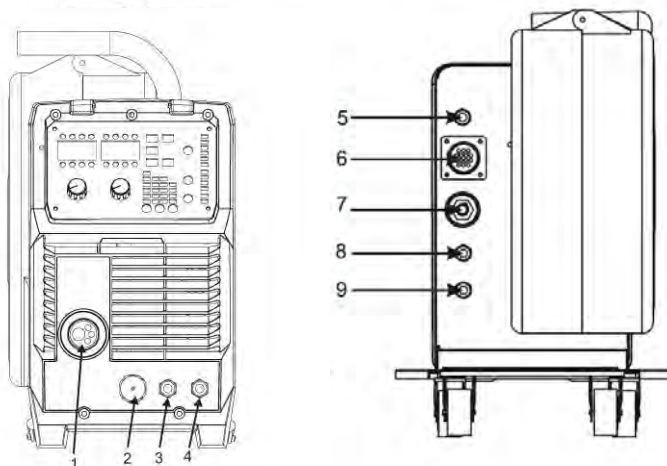

9. Water outlet connector (red)

§3.1.3 Internal panel layout of wire feeder

1. Spool holder assembly
2. Wire feed assembly

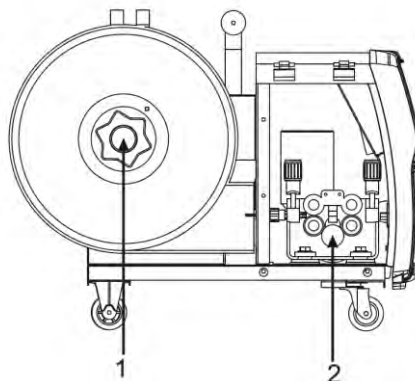

§3.1.4 Front and rear panel layout of water cooling

1. Water inlet
2. Water Inlet connector (blue)
3. Water outlet connector (red)
4. The water cooling control connector
5. Water Inlet connector (blue)
6. Water outlet connector (red)

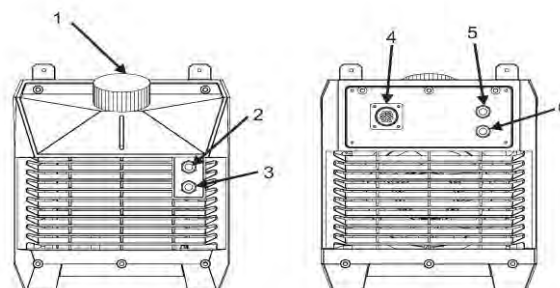

§3.2 Front Panel Functions and Descriptions

§3.2.1 Front Panel Functions of wire feeder

1. Adjustment Knob
2. Adjustment Knob
3. MIG-MAG Manual / MIG-MAG SYN selector switch
4. Manual wire key
5. 2T/4T /Spot Weld selector Switch
6. JOB key (Call save JOB parameters)
7. Gas/Air cooling mode Selector Switch
8. Save/Delete key (Press and hold the key to delete the job parameters that have been save)
9. Function key

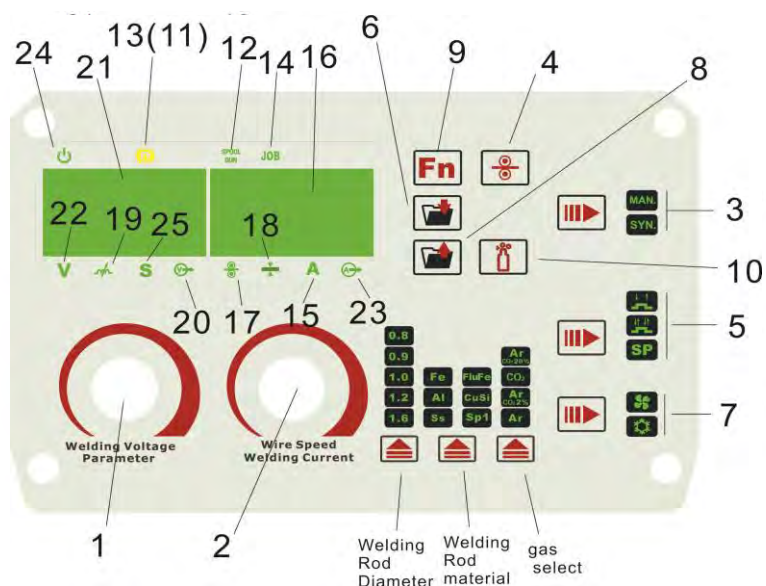



17. Wire feed LED

- 10. Air check key
- 11. No water LED
- 12. Spool Gun LED
- 13. Alarm Led
- 14. JOB LED
- 15. Welding current LED
- 16. The digital meter
- 25. Second Light
- 18. Material thickness
- 19. Inductance LED
- 20. voltage feedback LED
- 21. The digital meter
- 22. Welding voltage LED
- 23. Current feedback LED
- 24. Power LED

§3.2.2 Operating process of wire feeder

1) Welding method selection (press the selector switch(1) to select, the corresponding indicator light)

-  MIG-MAG Manual
-  MIG-MAG SYN

2) Welding mode selection (press the selector switch(2) to select, the corresponding indicator light)

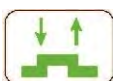

2T mode

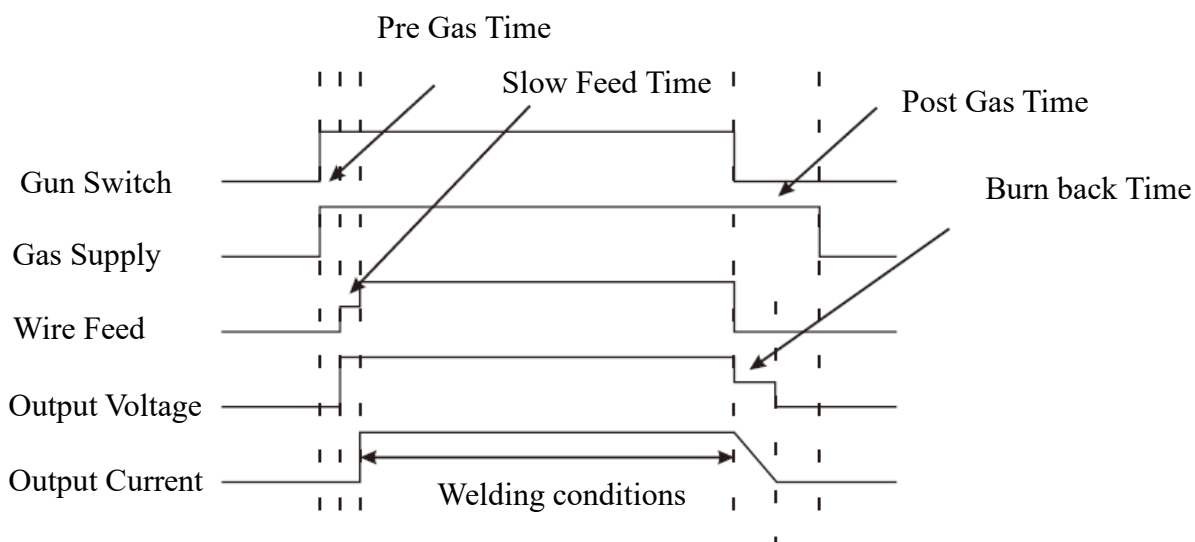
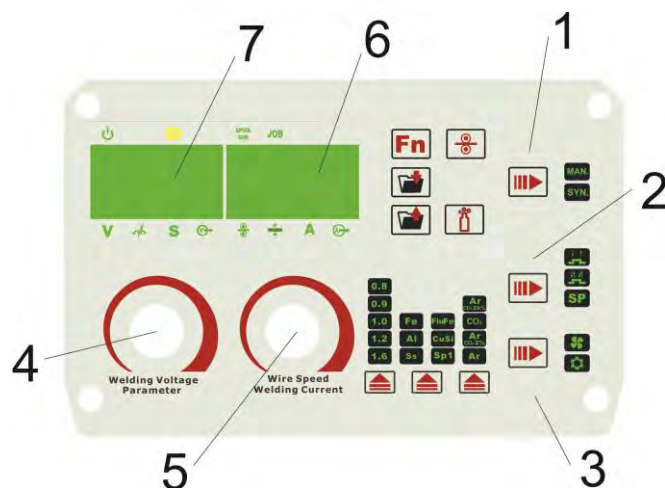



4T mode

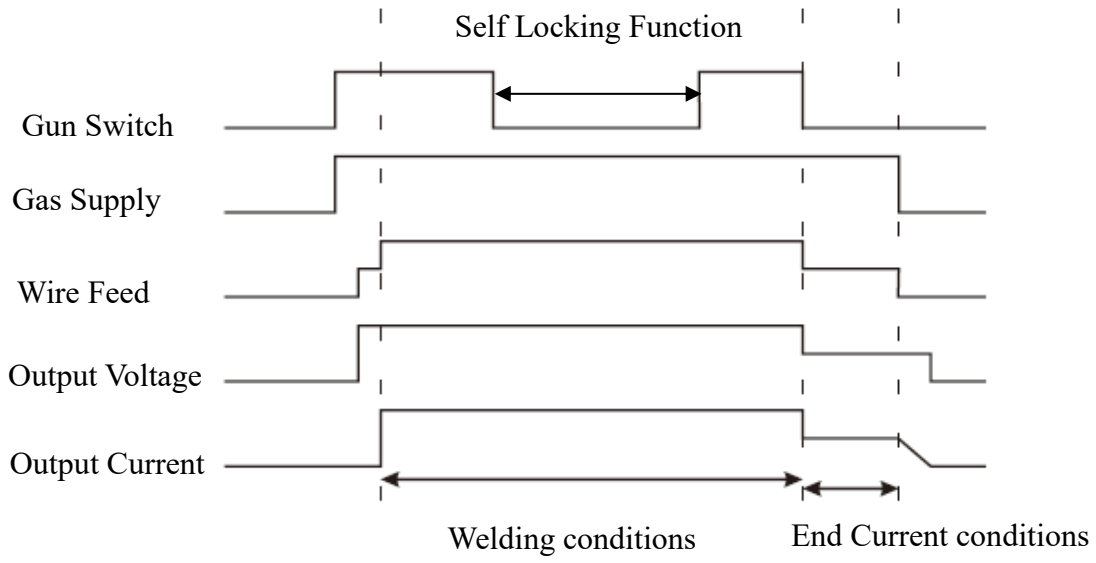

SP Spot weld

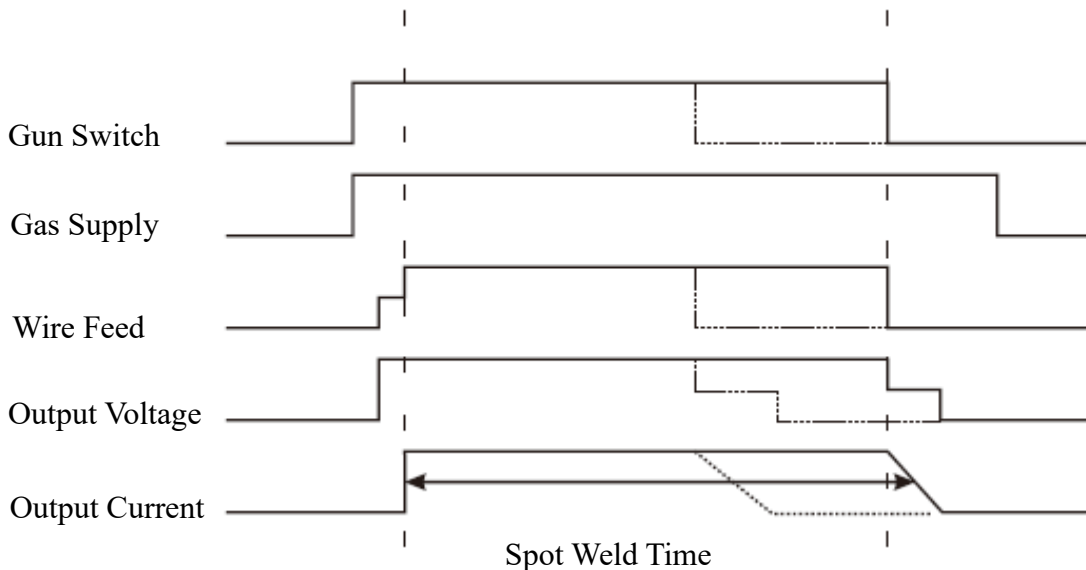

- 3) Cooling mode selection (press the selector switch(3) to select, the corresponding indicator light)
- 4) Synergic programs selection by the adjustment knob (4) , it will show on the digital meter (7) , refer to§ 4.4 (wire material/ wire diameter/protective gas)
- 5) Material thickness selection by the adjustment knob (5) , it will show on the digital meter (6) , begin to welding.
- 6) During the whole welding process, you can adjust arc length and Inductance by the knob (6) on the front panel (The optimal value of arc length and Inductance is "0").
 - Arc length adjustment: clockwise arc variable length, counterclockwise rotation, the arc becomes shorter;
 - Inductance adjustment: clockwise arc become soft, reduce spattering, also the arc is length, inverse clockwise arc hardens, splash increased, and the arc is shorter.

§3.2.3 Implicit parameter adjustment (Fn)

1) Implicit parameter menu and parameter adjustment method for import and export

- Press the function key (3), the indicator light that into the implicit function parameter adjusting mode.
- Select the parameter code that needs to be modified by the knob(1), it will show on the digital meter (5); Adjust the parameter value by the knob (2), it will show on the digital meter (4).

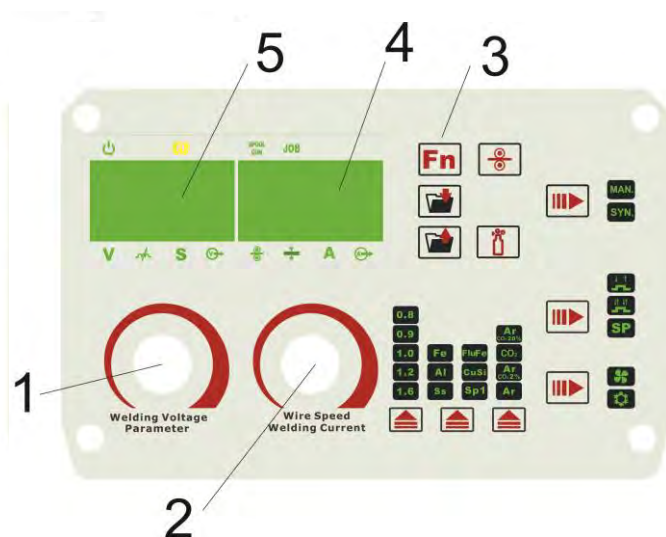

- Press the function key (3) again, the indicator light is off, exit implicit function parameter adjusting mode.

2) Implicit parameter function introduction

DISPLAY	FUNCTION	ADJUSTABLE RANGE	MODE
PrG	PRE GAS	0-5S	
PoG	POST GAS	0-10S	
SFt	SLOW FEED TIME	0-10S	
bub	BURN BACK	0-10	
SPt	SPOT WELD TIME	0-10S	
SPG	SPOOL GUN	oFF/on	
Dsl	DOWN SLOPE	0-10S	

§3.2.4 JOB mode

In the JOB mode, 100 different JOB records can be stored and called, improve the quality of welding process.

Save the JOB programs

Welding machine before leaving the factory did not save the JOB programs, to be called before, you must first save the JOB programs

- Set JOB mode parameters (welding function, welding mode, welding parameters, etc).
- Press the JOB key(3), go in save state.
- Select JOB number by the adjustment Knob (1), it will show on the digital meter (4).

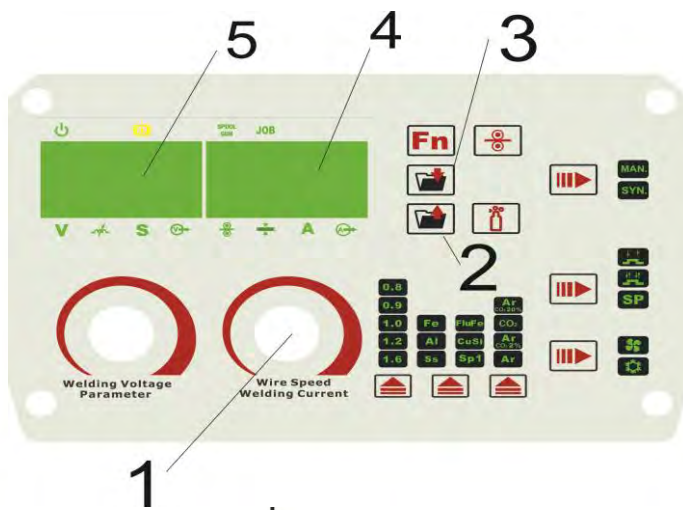

NOTE: the digital meter (5) display "---",the JOB number no JOB programs .

- Press the Save/Delete key (2),save successful.

Call the JOB programs

- Press the JOB key(2),the JOB LED is on.
- Select the required JOB number by the adjustment Knob (1), it will show on the digital meter (3).
- Press the JOB key(2) again, the JOB LED is off, exit JOB mode.

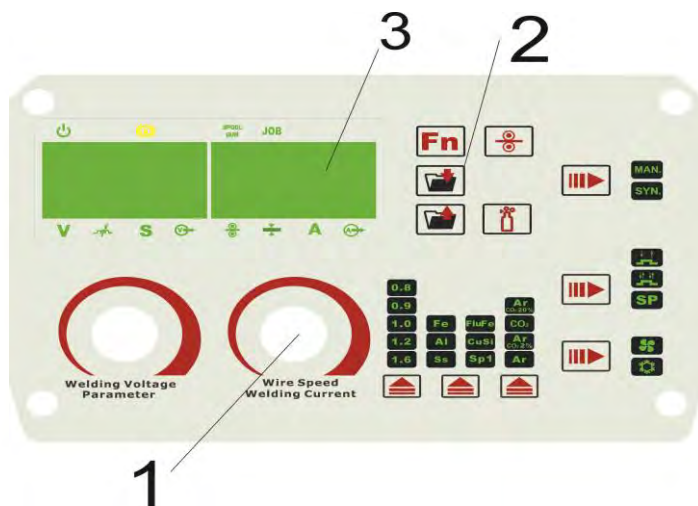

§3.2.5 Synergic Function

This makes the setup of MIG welding more simple, the operator simply sets the welding current like MMA or TIG welding and the machine calculates the optimal voltage and wire speed for the material type, wire type and size and shielding gas being used. Obviously other variables such as welding joint type and thickness, air temperature affect the optimal voltage and wire feed setting, so the program provides a voltage fine tuning function for the synergic program selected. Once the voltage is adjusted in a synergic program, it will stay fixed at this variation when the current

setting is changed. To reset the voltage for a synergic program back to factory default, change to another program and back again

The synergic programs are given a number from 1-23, this is accessed on the L display (21) using the L knob (1), indicator 'P'. To select the relevant program for the welding application, check the chart printed on the inside door of the wire feeder or further on in this manual.

§3.2.6 MMA Function - Front Panel Description

1. Welding Current /Arc Force /Hot Start Set
2. Welding Current /Arc Force /Hot Start Display
3. Hot Start LED
4. Welding Current LED
5. Arc Force LED

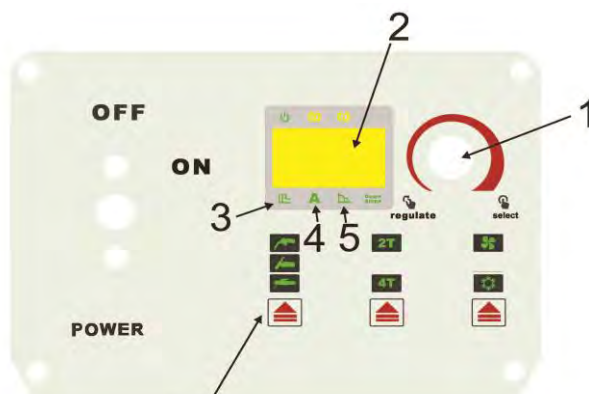

§3.2.7 TIG Function - Front Panel Description

Description

1. Welding Current /Down Slope Time Set
2. Welding Current /Down Slope Time Display
3. Down Slope Time LED
4. TIG Function Select
5. 2T/4T Trigger Select
6. Water/Air Cooling Mode Select

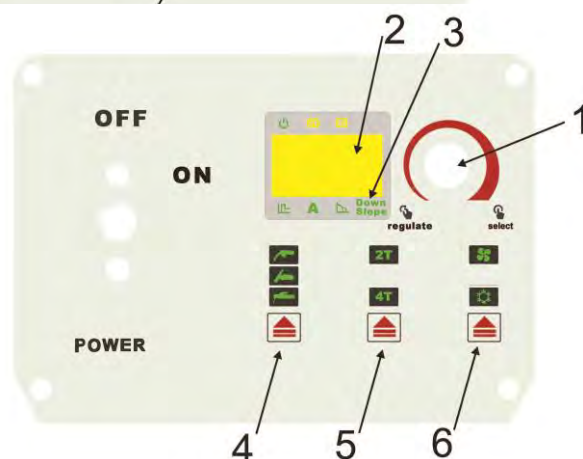

§3.2.8 MIG Function - Front Panel Description

MIG-MAG SYN Function

1. Synergic programs numbers select, refer to § 4.4
1. Voltage/ Arc length/ Inductance Set
2. Material thickness /Current/ Wire Speed Set
3. MIG-MAG Dual Pulse SYN Function Select
4. Manual Wire Select
5. 2T/4T /Spot Weld Select
6. Water/Air Cooling Mode Select
7. Function Select, refer to § 4.4

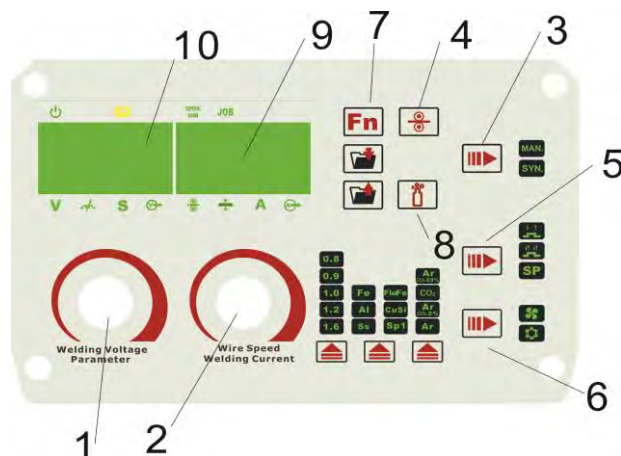

- 8. Air Check Select
- 9. Current/ Wire Speed / Material Thickness Display
- 10. Programs Numbers/ Voltage/ Arc length/ Inductance Display

MIG-MAG Manual Function

- 1. Voltage/ Inductance Set
- 2. Material thickness /Current/ Wire Speed Set
- 3. MIG-MAG Manual Function Select
- 4. Manual Wire Select
- 5. 2T/4T /Spot Weld Select
- 6. Water/Air Cooling Mode Select
- 7. Function Select, refer to § 4.4
- 8. Air Check Select
- 9. Material thickness /Current/ Wire Speed Display
- 10. Voltage/ Inductance Display

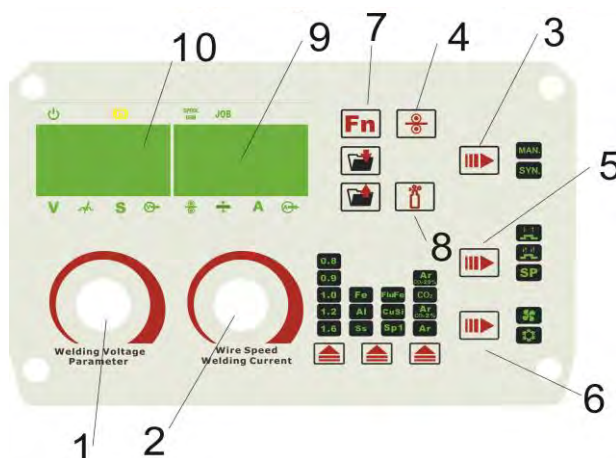

MIG-MAG SYN Function

- 1. Synergic programs numbers select, refer to § 4.4
- 1. Voltage/ Inductance Set
- 2. Material thickness /Current/ Wire Speed Set
- 3. MIG-MAG SYN Function Select
- 4. Manual Wire Select
- 5. 2T/4T /S4T/Spot Weld Select
- 6. Water/Air Cooling Mode Select
- 7. Function Select, refer to § 4.4
- 8. Air Check Select
- 9. Material thickness /Current/ Wire Speed Display
- 10. Programs Numbers /Voltage/ Inductance Display

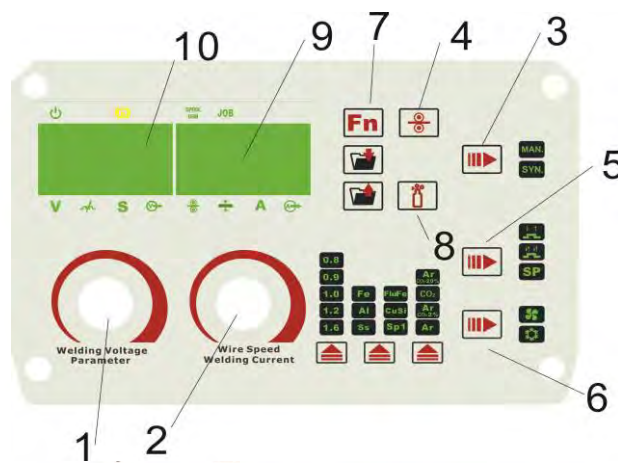

§4 Installation & Operation

§4.1 Installation & Operation for MMA Welding

§4.1.1 Set up installation for MMA Welding

(1) Connection of Output Cables

Connection of Output Cables Two sockets are available on this welding machine. For MMA welding the electrode holder is shown be connected to the positive socket, while the earth lead (work piece) is connected to the negative socket, this is known as DCEP. However various electrodes require a different polarity for optimum results and careful attention should be paid to the polarity, refer to the electrode manufacturers information for the correct polarity.

DCEP: Electrode connected to “+” output socket.

DCEN: Electrode connected to “-” output socket.

(2) Turn the power source on and press the TIG/MMA/MIG key to select the MMA function.

(3) Set the welding current relevant to the electrode type and size being used as recommended by the electrode manufacturer.

(4) Set the Hot Start and Arc Force using the knob.

Set the welding current /Hot Start and Arc Force using the knob

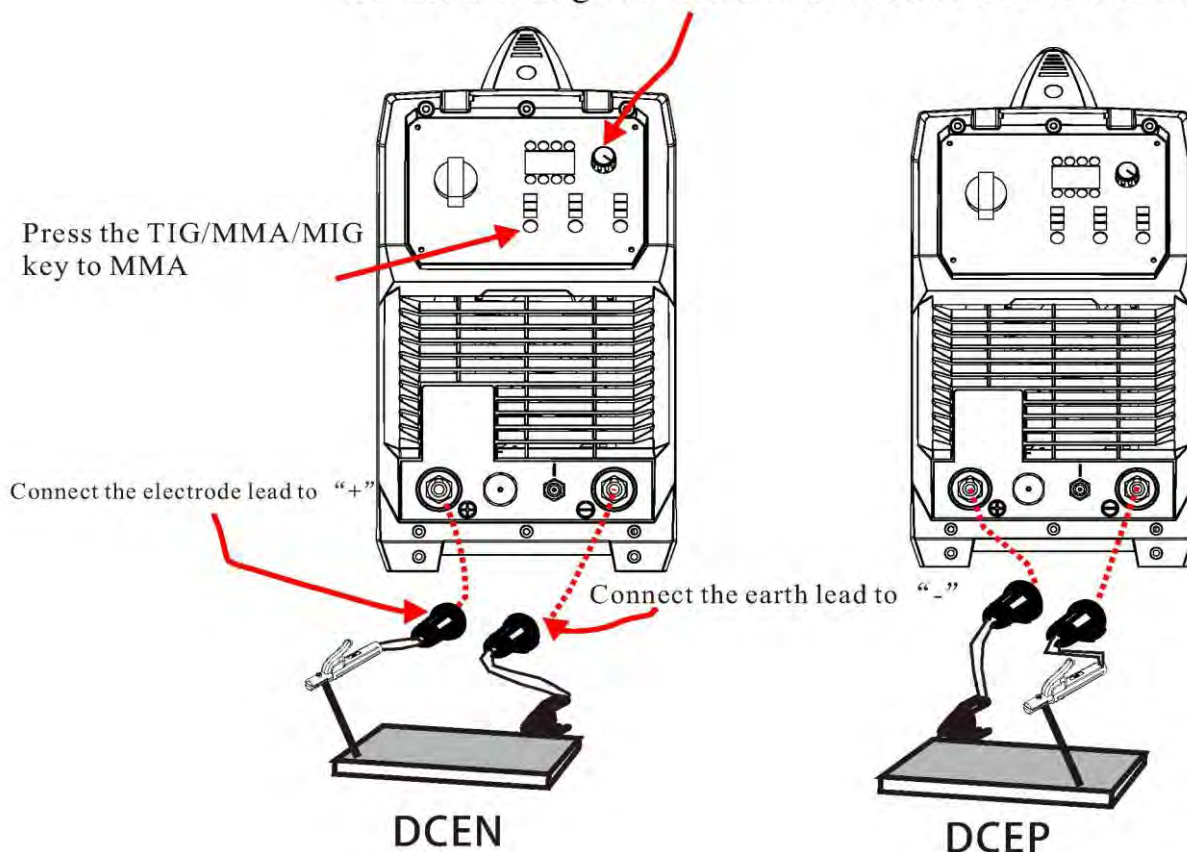

(5) Place the electrode into the electrode holder and clamp tight.

(6) Strike the electrode against the work piece to create and arc and hold the electrode steady to maintain the arc.

§4.1.2 MMA Welding

One of the most common types of arc welding is manual metal arc welding (MMA) or stick welding. An electric current is used to strike an arc between the base material and a consumable electrode rod or 'stick'. The electrode rod is made of a material that is compatible with the base material being welded and is covered with a flux that gives off gaseous vapours that serve as a shielding gas and providing a layer of slag, both of which protect the weld area from atmospheric contamination. The electrode core itself acts as filler material the residue from the flux that forms slag covering over the weld metal must be chipped away after welding.

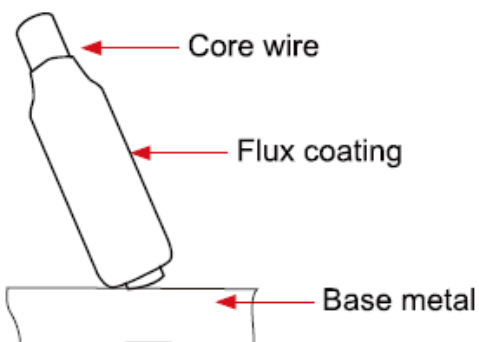
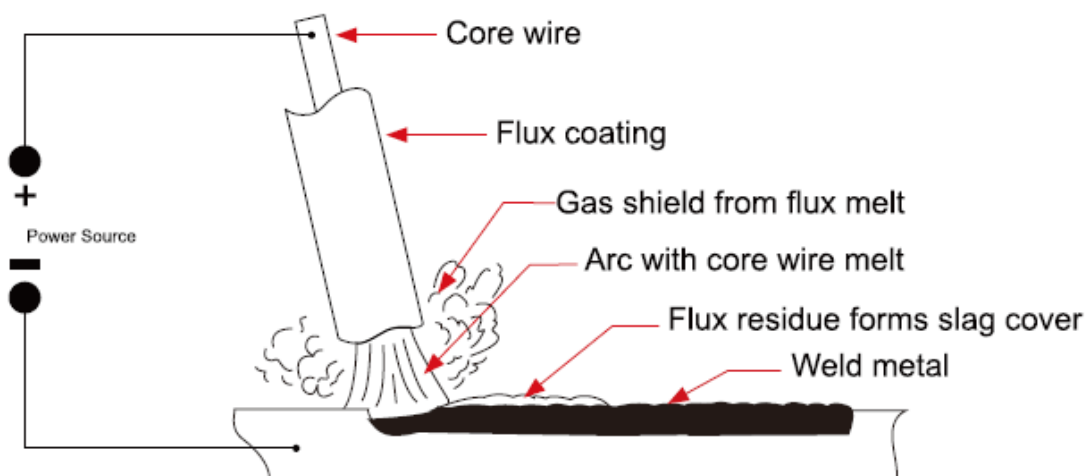

- The arc is initiated by momentarily touching the electrode to the base metal.
- The heat of the arc melts the surface of the base metal to form a molten pool at the end of the electrode.
- The melted electrode metal is transferred across the arc into the molten pool and becomes the deposited weld metal.
- The deposit is covered and protected by a slag which comes from the electrode coating.
- The arc and the immediate area are enveloped by an atmosphere of protective gas

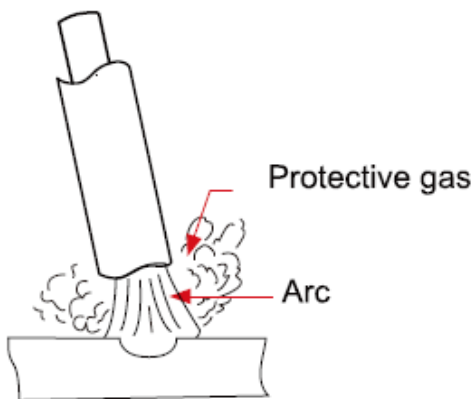

Manual metal arc (stick) electrodes have a solid metal wire core and a flux coating. These electrodes are identified by the wire diameter and by a series of letters and numbers. The letters and numbers identify the metal alloy and the intended use of the electrode.

The **Metal Wire Core** works as conductor of the current that maintains the arc. The core wire melts and is deposited into the welding pool.

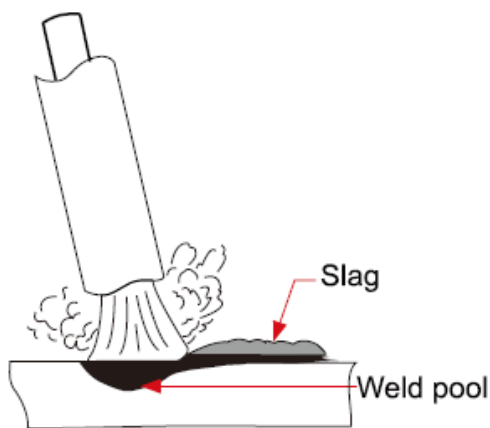

The covering on a shielded metal arc welding electrode is called **Flux**.

The flux on the electrode performs many different functions.

These include:

- producing a protective gas around the weld area
- providing fluxing elements and deoxidizer
- creating a protective slag coating over the weld as it cools ●
- establishing arc characteristics
- adding alloying elements.

Covered electrodes serve many purposes in addition to filler metal to the molten pool. These additional functions are provided mainly by the covering on the electrode.

§4.1.3 MMA Welding Fundamentals

Electrode Selection

As a general rule, the selection of an electrode is straight forward, in that it is only a matter of selecting an electrode of similar composition to the parent metal. However, for some metals there is a choice of several electrodes, each of which has particular properties to suit specific classes of work. It is recommended to consult your welding supplier for the correct selection of electrode.

Electrode Size

Average Thickness of Material	Maximum Recommended Electrode Diameter
1.0-2.0 mm	2.5 mm
2.0-5.0 mm	3.2 mm
5.0-8.0 mm	4.0 mm
>8.0 mm	5.0 mm

The size of the electrode generally depends on the thickness of the section being welded, and the thicker the section the larger the electrode required. The table gives the maximum size of electrodes that maybe used for various thicknesses of section base on using a general purpose type 6013 electrode.

Welding Current (Amperage)

Electrode Size ø mm	Current Range (Amps)
2.5 mm	60-95
3.2 mm	100-130
4.0 mm	130-165
5.0 mm	165-260

Correct current selection for a particular job is an important factor in arc welding. With the current set too low, difficulty is experienced in striking and maintaining a stable arc. The electrode tends to stick to the work, penetration is poor and beads with a distinct rounded profile will be deposited. Too high current is accompanied by overheating of the

electrode resulting undercut and burning through of the base metal and producing excessive spatter. Normal current for a particular job may be considered as the maximum, which can be used without burning through the work, over-heating the electrode or producing a rough spattered surface. The table shows current ranges generally recommended for a general purpose type 6013 electrode.

Arc Length

To strike the arc, the electrode should be gently scraped on the work until the arc is established. There is a simple rule for the proper arc length; it should be the shortest arc that gives a good surface to the weld. An arc too long reduces penetration, produces spatter and gives a rough surface finish to the weld. An excessively short arc will cause sticking of the electrode and result in poor quality welds. General rule of thumb for down hand welding is to have an arc length no greater than the diameter of the core wire.

Electrode Angle

The angle that the electrode makes with the work is important to ensure a smooth, even transfer of metal. When welding in down hand, fillet, horizontal or overhead the angle of the electrode is generally between 5 and 15 degrees towards the direction of travel. When vertical up welding the angle of the electrode should be between 80 and 90 degrees to the work piece.

Travel Speed

The electrode should be moved along in the direction of the joint being welded at a speed that will give the size of run required. At the same time, the electrode is fed downwards to keep the correct arc length at all times. Excessive travel speeds lead to poor fusion, lack of penetration etc, while too slow a rate of travel will frequently lead to arc instability, slag inclusions and poor mechanical properties.

Material and Joint Preparation

The material to be welded should be clean and free of any moisture, paint, oil, grease, mill scale, rust or any other material that will hinder the arc and contaminate the weld material. Joint preparation will depend on the method used include sawing, punching, shearing, machining, flame cutting and others. In all cases edges should be clean and free of any contaminants. The type of joint will be determined by the chosen application.

§4.2 Installation & Operation for TIG Welding**§4.2.1 Set up installation for TIG Welding**

- (1) Insert the earth cable plug into the positive socket on the front of the machine and tighten it.
- (2) Plug the welding torch into the negative socket on the front panel, and tighten it.
- (3) Connect the gas line of TIG Gun to outlet gas connector on the front of the machine . **Check for Leaks!**
- (4) Connect the control cable of torch switch to 12 pin socket on the front of the machine .
- (5) Connect the water inlet and outlet pipe of TIG Gun to inlet and outlet water connector on the front of the cooling water .
- (6) Connect the control cable of cooling water with the aero socket on the rear panel of welding machine.
- (7) Connect the gas regulator to the Gas Cylinder and connect the gas line to the Gas Regulator.

Check for Leaks!

- (8) Connect the gas line to the machine inlet gas connector via the quick push lock connector located on the rear panel. **Check for Leaks!**
- (9) Connect the power cable of welding machine with the output switch in electric box on site.

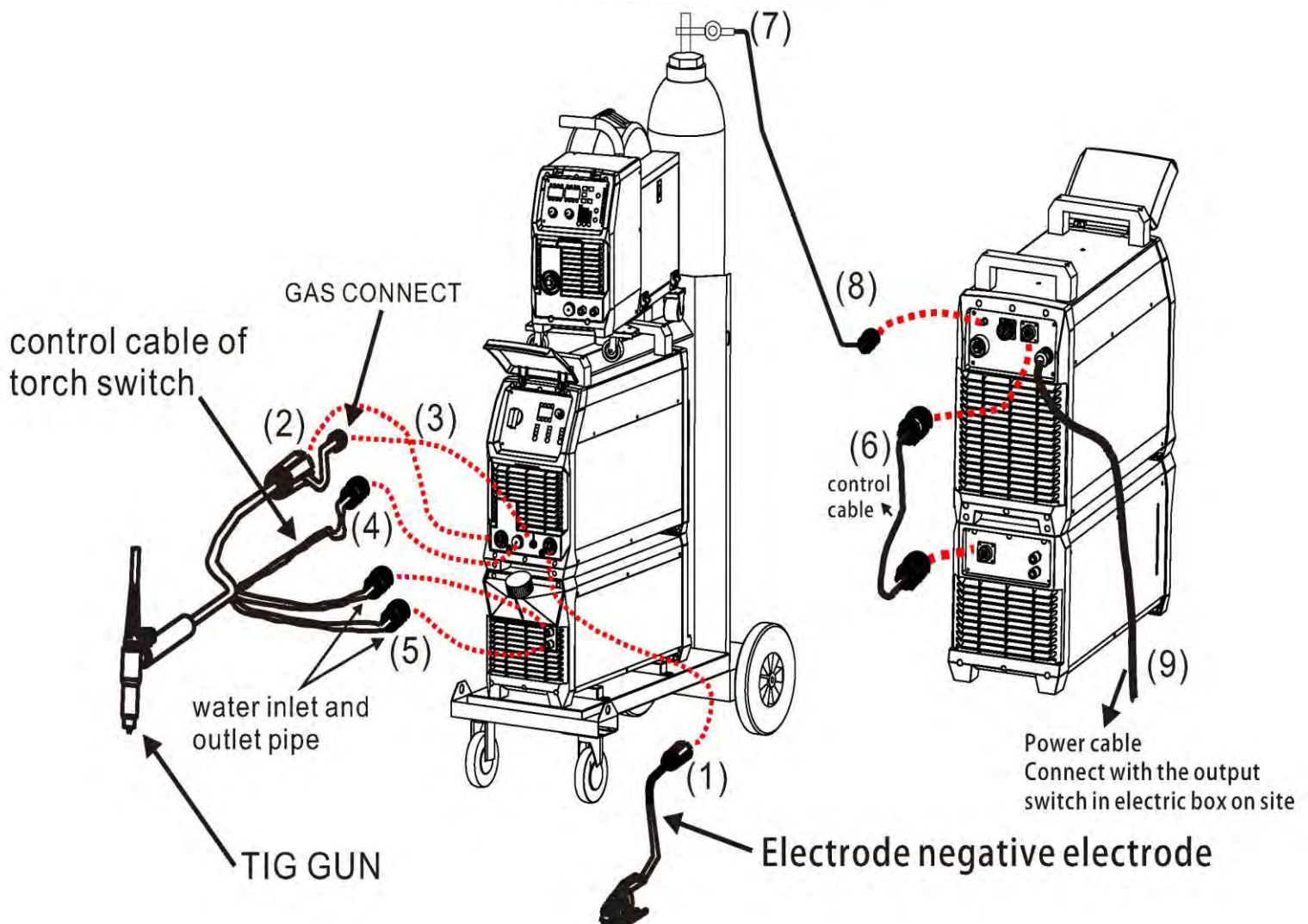

NOTE: Air cooling mode without cooling device, and the water pipe is not needed for the air cooling mode.

- (10) Carefully open the valve of the gas cylinder, set the required gas flow rate.
- (11) Select TIG function on the front panel.
- (12) Set torch operation 2T / 4T.
 - When 2T operation is selected press trigger Gas starts, touch and lift arc start, release trigger Gas and Arc stops.
 - When 4T operation is selected press and release trigger Gas starts, touch and lift arc start, press and release trigger Gas and Arc stops.
- (13) Select cooling mode gas / water on the front panel.

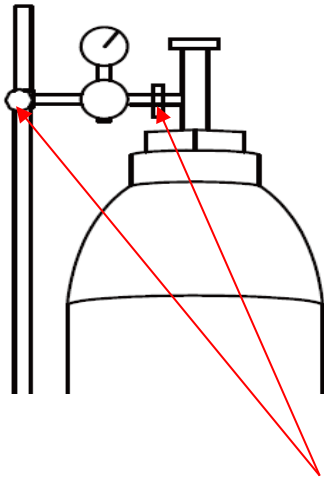

(10) Carefully open the valve of the gas cylinder, set the required gas flow rate.

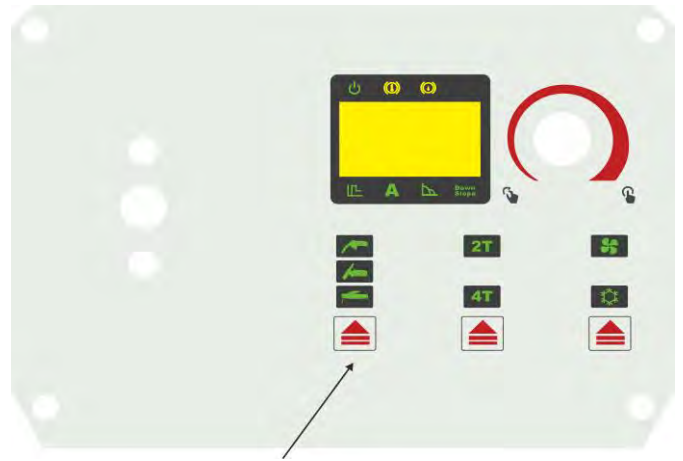

(11) Select TIG function using the key.

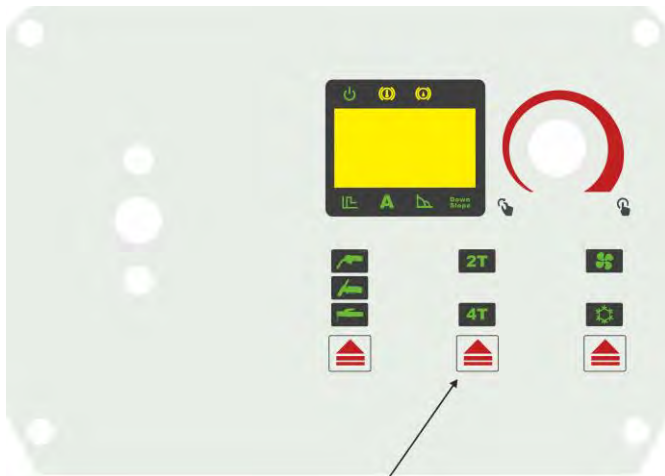

(12) Select 2T, 4T Trigger as required using the key.



(13) Select gas / water cooling mode .

LIFT ARC DC TIG Operation

Lift Arc ignition allows the arc to be started easily in DC TIG by simply touching the tungsten to the work piece and lifting it up to start the arc. This prevents the tungsten tip sticking to the work piece and breaking the tip from the tungsten electrode. There is a particular technique called “rocking the cup” used in the Lift Arc process that provides easy use of the Lift Arc function.

(14) Select welding current and Down slope Time as required on the front panel. The selected welding current and Down slope Time will show on the digital meter.

(15) Assemble front end parts of the TIG torch making sure they are correctly assembled, use the correct size and type of tungsten electrode for the job, the tungsten electrode requires a sharpened point for DC welding.

(16) Lay the outside edge of the Gas Cup on the work piece with the Tungsten Electrode 1-

2mm from the work piece. Press and hold the torch switch to activate to gas flow and welding power.

(17) With a small movement rotate the Gas Cup forward so that the Tungsten Electrode touches the work piece.

(18) Now rotate the Gas Cup in the reverse direction to lift the Tungsten electrode from the work piece to create the arc.

(19) Release the trigger to stop the welding.

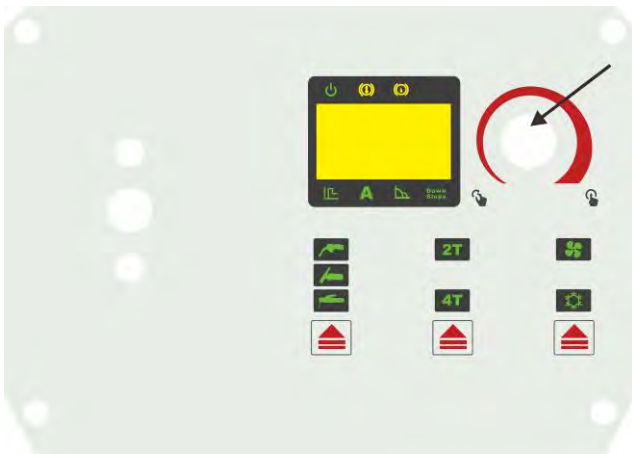

(14) Select the required Amperage and Down slope Time using the control knob.



(15) Assemble front end parts of the TIG torch, fitting a sharpened tungsten suitable for DC welding.



(16) Lay the outside edge of the Gas Cup on the work piece with the Tungsten Electrode 1- 2mm from the work piece. Press and hold the trigger button on TIG torch to start the gas flow.



(17) With a small movement rotate the Gas Cup forward so that the Tungsten Electrode touches the work piece.



(18) Now rotate the Gas Cup in the reverse direction to lift the Tungsten electrode from the work piece to create the arc.

(19) Release the trigger to stop the welding.

IMPORTANT! - We strongly recommend that you check for gas leaks prior to operation of your machine. We recommend that you close the cylinder valve when the machine is not in use.

§4.2.2 DC TIG Welding

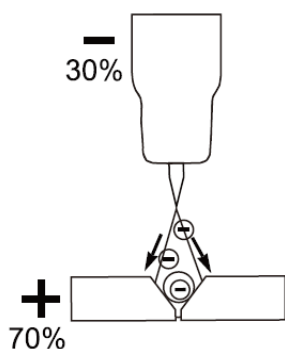

The DC power source uses what is known as DC (direct current) in which the main electrical component known as electrons flow in only one direction from the negative pole (terminal) to the positive pole (terminal). In the DC electrical circuit there is an electrical principle at work which should always be taken into account when using any DC circuit. With a DC circuit 70% of the energy (heat) is always on the positive side. This needs to be understood because it determines what

terminal the TIG torch will be connected to (this rule applies to all the other forms of DC welding as well).

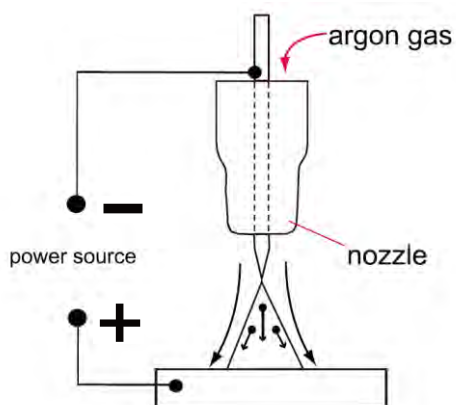

DC TIG welding is a process in which an arc is struck between a TUNGSTEN electrode and the metal work piece. The weld area is shielded by an inert gas flow to prevent contamination of the tungsten, molten pool and weld area. When the TIG arc is struck the inert gas is ionized and superheated changing its molecular structure which converts

it into a plasma stream. This plasma stream flowing between the tungsten and the work piece is

the TIG arc and can be as hot as 19,000°C. It is a very pure and concentrated arc which provides the controlled melting of most metals into a weld pool. TIG welding offers the user the greatest amount of flexibility to weld the widest range of material and thickness and types. DC TIG welding is also the cleanest weld with no sparks or spatter.

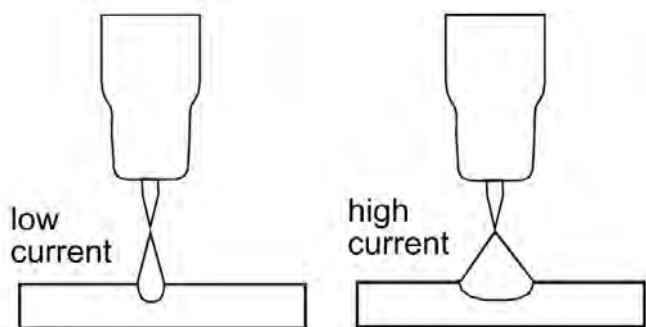

The intensity of the arc is proportional to the current that flows from the tungsten. The welder regulates the welding current to adjust the power of the arc. Typically thin material requires a less powerful arc with less heat to melt the material so less current (amps) is

required, thicker material requires a more powerful arc with more heat so more current (amps) are necessary to melt the material.

LIFT ARC IGNITION for TIG (tungsten inert gas) Welding

Lift Arc is a form of arc ignition where the machine has low voltage on the electrode to only a few volts, with a current limit of one or two amps (well below the limit that causes metal to transfer and contamination of the weld or electrode). When the machine detects that the tungsten has left the surface and a spark is present, it immediately (within microseconds) increases power, converting the spark to a full arc. It is a simple, safe lower cost alternative arc ignition process to HF (high frequency) and a superior arc start process to scratch start.

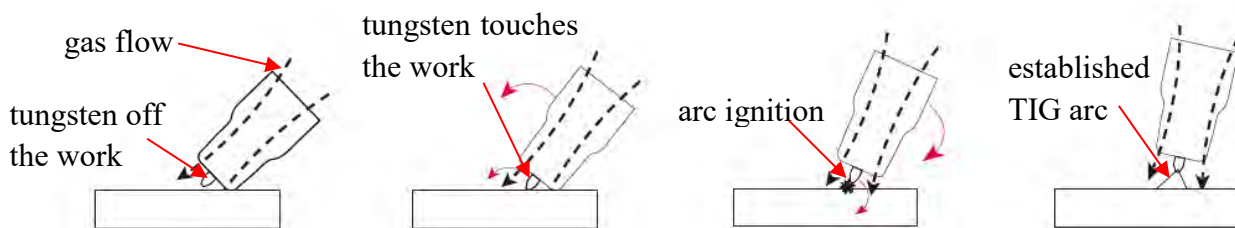

Lay the nozzle on the job without the tungsten touching the work.

Rock the torch sideways so that the tungsten touches the work & hold momentarily.

Rock the torch back in the opposite direction, the arc will ignite as the tungsten lifts off the work.

Lift the torch to maintain the arc.

§4.2.3 TIG Welding Fusion Technique

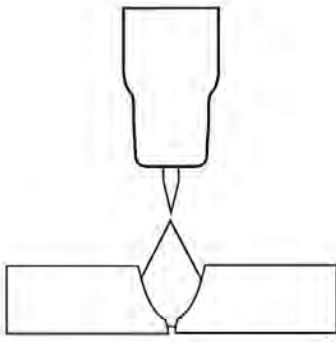

Manual TIG welding is often considered the most difficult of all the welding processes. Because the welder must maintain a short arc length, great care and skill are required to prevent contact between the electrode and the work piece. Similar to Oxygen Acetylene torch welding, Tig welding normally requires two hands and in most instances requires the welder to manually feed a filler wire into the weld pool with one hand while manipulating the welding torch in the other. However, some welds combining thin materials can be accomplished without filler metal like edge, corner, and butt joints. This is known as Fusion welding where the edges of the metal pieces are melted together using only the heat and arc force generated by the TIG arc. Once the arc is started the tungsten is held in place until a weld pool is created, a circular movement of the tungsten will assist in creating a weld pool of the desired size. Once the weld pool is established tilt the torch at about a 75° angle and move smoothly and evenly along the joint while fusing the materials together.

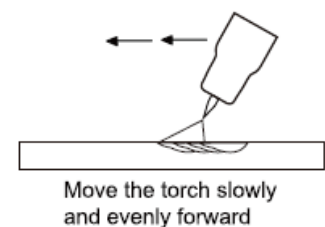
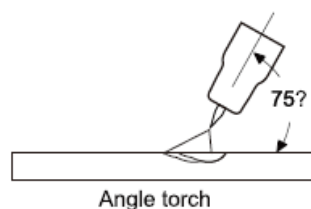
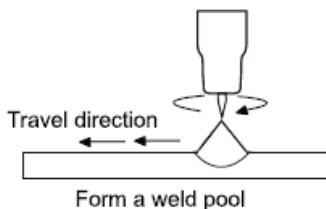

TIG Welding with Filler Wire Technique

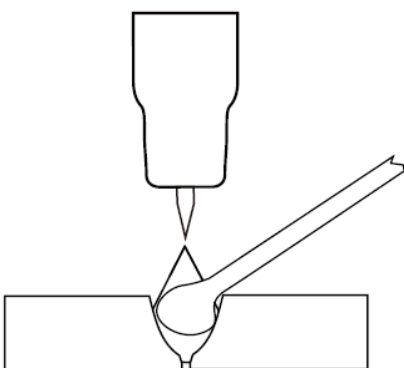

It is necessary in many situations with TIG welding to add a filler wire into the weld pool to build up weld reinforcement and create a strong weld. Once the arc is started the tungsten is held in place until a weld pool is created, a circular movement of the tungsten will assist in creating a weld pool of the desired size. Once the weld pool is established tilt the torch at about a 75° angle and move smoothly and evenly along the

joint. The filler metal is introduced to the leading edge of the weld pool. The filler wire is usually held at about a 15° angle and fed into the leading edge of the molten pool, the arc will melt the filler wire into the weld pool as the torch is moved forward. Also a dabbing technique can be used to control the amount of filler wire added, the wire is fed into the molten pool and retracted in a repeating sequence as the torch is moved slowly and evenly forward. It is important during the welding to keep the molten end of the filler wire inside the gas shield as this protects the end of the wire from being oxidised and contaminating the weld pool

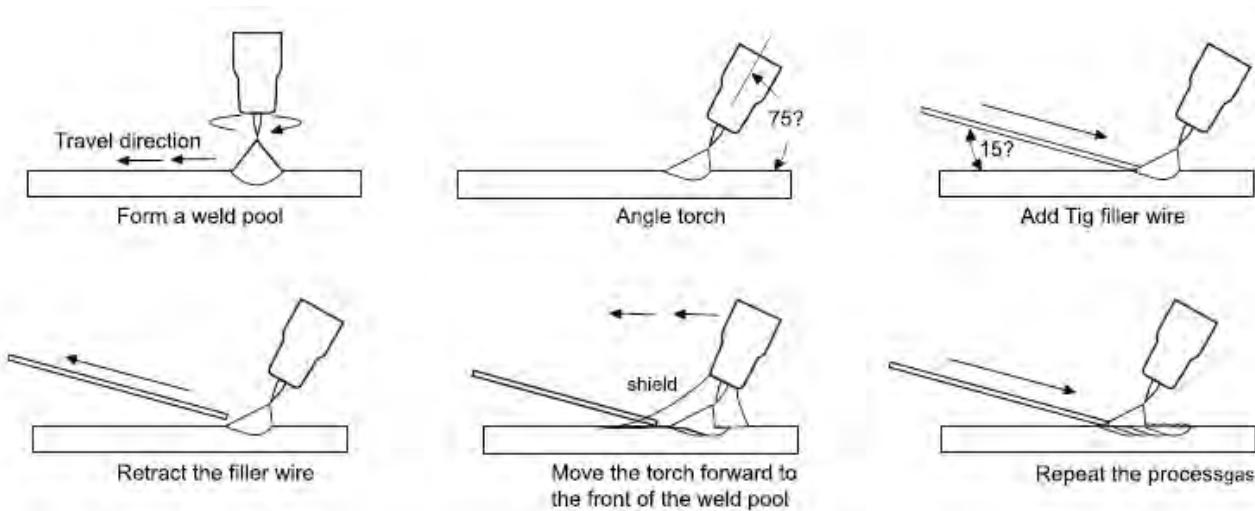

§4.2.4 Tungsten Electrodes

Tungsten is a rare metallic element used for manufacturing TIG welding electrodes. The TIG process relies on tungsten's hardness and high-temperature resistance to carry the welding current to the arc. Tungsten has the highest melting point of any metal, 3,410 degrees Celsius. Tungsten electrodes are nonconsumable and come in a variety of sizes, they are made from pure tungsten or an alloy of tungsten and other rare earth elements. Choosing the correct tungsten depends on the material being welded, amps required and whether you are using AC or DC welding current. Tungsten electrodes are colour-coded at the end for easy identification. Below are the most commonly used tungsten electrodes found in the New Zealand and Australian market.

Thoriated

Thoriated tungsten electrodes (AWS classification EWTh-2) contain a minimum of 97.30 percent tungsten and 1.70 to 2.20 percent thorium and are called 2 percent thoriated. They are the most commonly used electrodes today and are preferred for their longevity and ease of use. Thorium

however is a low-level radioactive hazard and many users have switched to other alternatives. Regarding the radioactivity, thorium is an alpha emitter but when it is enclosed in a tungsten matrix the risks are negligible. Thoriated tungsten should not get in contact with open cuts or wounds. The more significant danger to welders can occur when thorium oxide gets into the lungs. This can happen from the exposure to vapours during welding or from ingestion of material/dust in the grinding of the tungsten. Follow the manufacturer's warnings, instructions, and the Material Safety Data Sheet (MSDS) for its use.

E3 (Color Code: Purple) 

E3 tungsten electrodes (AWS classification EWG) contain a minimum of 98% percent tungsten and up to 1.5 percent Lanthanum and small percentages of Zirconium and Yttrium they are called E3 Tungsten. E3 Tungsten Electrodes provide conductivity similar to that of thoriated electrodes. Typically, this means that E3 Tungsten Electrodes are exchangeable with thoriated electrodes without requiring significant welding process changes. E3 deliver superior arc starting, electrode lifetime, and overall cost-effectiveness. When E3 Tungsten Electrodes are compared with 2% thoriated tungsten, E3 requires fewer re-grinds and provides a longer overall lifetime. Tests have shown that ignition delay with E3 Tungsten Electrodes actually improves over time, while 2% thoriated tungsten starts to deteriorate after only 25 starts. At equivalent energy output, E3 Tungsten Electrodes run cooler than 2% thoriated tungsten, thereby extending overall tip lifetime. E3 Tungsten Electrodes work well on AC or DC. They can be used DC electrode positive or negative with a pointed end, or balled for use with AC power sources.

Ceriated (Color Code: Orange) 

Ceriated tungsten electrodes (AWS classification EWCe-2) contain a minimum of 97.30 percent tungsten and 1.80 to 2.20percent cerium and are referred to as 2 percent ceriated. Ceriated tungstens perform best in DC welding at low current settings. They have excellent arc starts at low amperages and become popular in such applications as orbital tube welding, thin sheet metal work. They are best used to weld carbon steel, stainless steel, nickel alloys, and titanium, and in some cases it can replace 2 percent thoriated electrodes. Ceriated tungsten is best suited for lower amperages it should last longer than Thoriated tungsten higher amperage applications are best left to Thoriated or Lanthanated tungsten.

Lanthanated (Color Code: Gold) 

Lanthanated tungsten electrodes (AWS classification EWLa-1.5) contain a minimum of 97.80 percent tungsten and 1.30percent to 1.70 percent lanthanum, and are known as 1.5 percent lanthanated. These electrodes have excellent arc starting, a low burn off rate, good arc stability, and excellent re-ignition characteristics. Lanthanated tungstens also share the conductivity characteristics of 2 percent thoriated tungsten. Lanthanated tungsten electrodes are ideal if you want to opti-mise your welding capabilities. They work well on AC or DC electrode negative with a pointed end, or they can be balled for use with AC sine wave power sources. Lanthanated tungsten maintains a sharpened point well, which is an advantage for welding steel and stainless steel on DC or AC from square wave power sources.

Zirconiated (Color Code: White) 

Zirconiated tungsten electrodes (AWS classification EWZr-1) contain a minimum of 99.10 percent tungsten and 0.15 to 0.40percent zirconium. Most commonly used for AC welding Zirconiated tungsten produces a very stable arc and is resistant to tungsten spitting. It is ideal for AC welding because it retains a balled tip and has a high resistance to contamination. Its current-carrying capacity is equal to or greater than that of thoriated tungsten. Zirconiated tungsten is not recommended for DC welding.

Tungsten Electrodes Rating for Welding Currents

Tungsten Diameter mm	DC Current Amps Torch Negative 2% Thoriated	AC Current Amps Un-Balanced Wave 0.8% Zirconiated	AC Current Amps Balanced Wave 0.8% Zirconiated
1.0mm	15-80	15-80	20-60
1.6mm	70-150	70-150	60-120
2.4mm	150-250	140-235	100-180
3.2mm	250-400	225-325	160-250
4.0mm	400-500	300-400	200-320

§4.2.5 Tungsten Preparation

Always use **DIAMOND** wheels when grinding and cutting. While tungsten is a very hard material, the surface of a diamond wheel is harder, and this makes for smooth grinding. Grinding without diamond wheels, such as aluminium oxide wheels, can lead to jagged edges, imperfections, or poor surface finishes not visible to the eye that will contribute to weld inconsistency and weld defects.

Always ensure to grind the tungsten in a longitudinal direction on the grinding wheel. Tungsten electrodes are manufactured with the molecular structure of the grain running lengthwise and thus grinding crosswise is “grinding against the grain.” If electrodes are ground crosswise, the electrons have to jump across the grinding marks and the arc can start before the tip and wander. Grinding longitudinally with the grain, the electrons flow steadily and easily to the end of the tungsten tip. The arc starts straight and remains narrow, concentrated, and stable.



Electrode Tip/Flat

The shape of the tungsten electrode tip is an important process variable in precision arc welding. A good selection of tip/flat size will balance the need for several advantages. The bigger the flat, the more likely arc wander will occur and the more difficult it will be to arc start. However, increasing the flat to the maximum level that still allows arc start and eliminates arc wander will improve the weld penetration and increase the electrode life. Some welders still grind electrodes to a sharp point, which makes arc starting easier. However, they risk decreased welding performance from melting at the tip and the possibility of the point falling off into the weld pool.

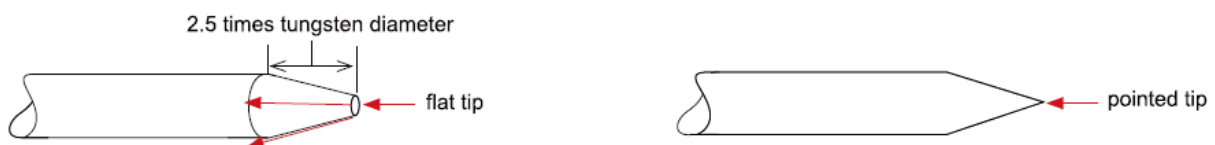

Electrode Included Angle/Taper - DC Welding

Tungsten electrodes for DC welding should be ground longitudinally and concentrically with diamond wheels to a specific included angle in conjunction with the tip/flat preparation. Different angles produce different arc shapes and offer different weld penetration capabilities. In general, blunter electrodes that have a larger included angle provide the following benefits:

- Last Longer
- Have better weld penetration
- Have a narrower arc shape
- Can handle more amperage without eroding.



Sharper electrodes with smaller included angle provide:

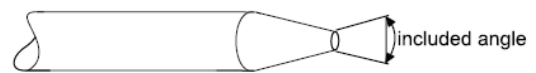

- Offer less arc weld
- Have a wider arc
- Have a more consistent arc

The included angle determines weld bead shape and size. Generally, as the included angle increases, penetration increases and bead width decreases.

Tungsten Diameter	Diameter at the Tip - mm	Constant Included Angle - Degrees	Current Range Amps	Current Range Pulsed Amps
1.0mm	.250	20	05 - 30	05 - 60
1.6mm	.500	25	08 - 50	05 - 100
1.6mm	.800	30	10 - 70	10 - 140
2.4mm	.800	35	12 - 90	12 - 180
2.4mm	1.100	45	15 - 150	15 - 250
3.2mm	1.100	60	20 - 200	20 - 300
3.2mm	1.500	90	25 - 250	25 - 350

§4.2.6 Gun switch control current

UP/DOWN GUN



Gun switch

Adjust current button, when it's pushed up, the current increase, when it's pushed down, the current decrease.

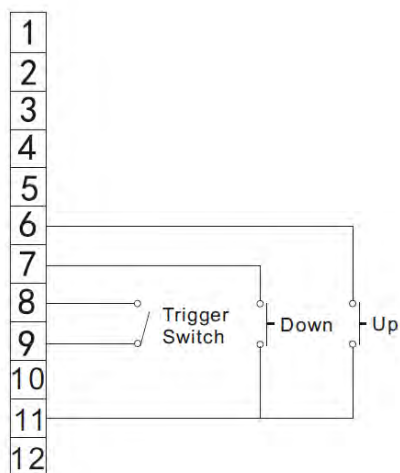
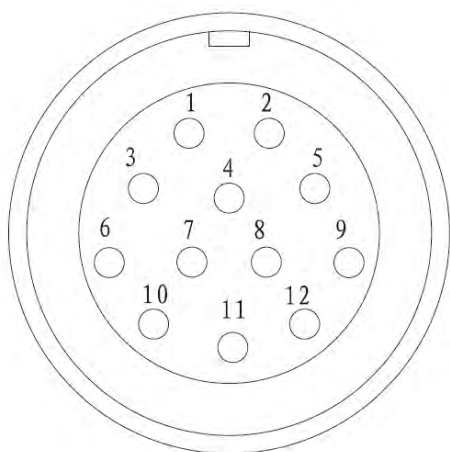

Remote Control Socket

Socket Pin	Function
1	Not connected
2	Not connected
3	Not connected
4	Not connected
5	Not connected
6	The button of "UP" input
7	The button of "DOWN" input
8	Trigger Switch Input
9	Trigger Switch Input
10	Not connected
11	The button of "UP"& "DOWN" input
12	Not connected

REMOTE GUN



Gun switch

Adjust current roller wheel, when it's roll upwards, the current increase, when it's roll downwards, the current decrease.

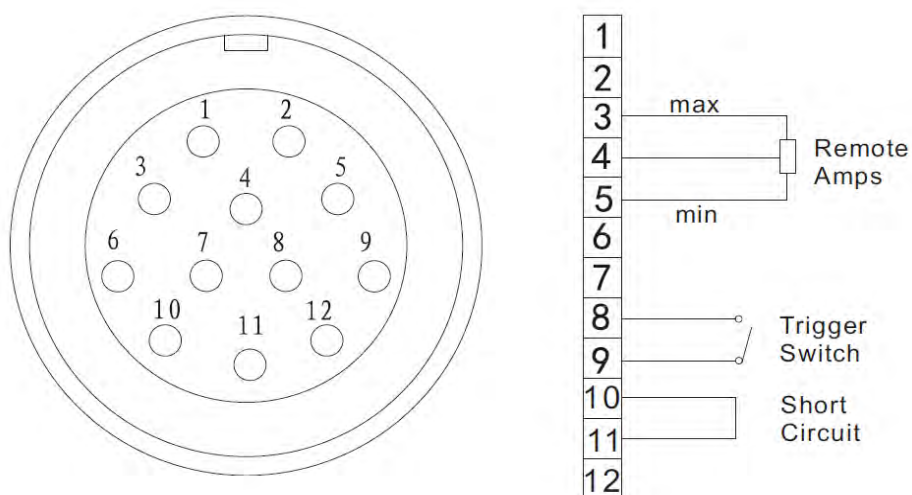

Remote Control Socket

Socket Pin	Function
1	Not connected
2	Not connected
3	10k ohm (maximum) connection to 10k ohm remote control potentiometer
4	Wiper arm connection to 10k ohm remote control potentiometer
5	Zero ohm (minimum) connection to 10k ohm remote control potentiometer
6	Not connected
7	Not connected
8	Trigger Switch Input
9	Trigger Switch Input
10	Be shorted with 11
11	Be shorted with 10
12	Not connected

§4.2.7 Pedal switch control

- When plug the twelve-lead aero-socket of pedal switch in it. Welder will identify the pedal switch, the welding current knob on the front panel will can't use, and only 2T can be selected.
- When use the adjustment knob of max-welding current beside the pedal ,can set the max-current you want.

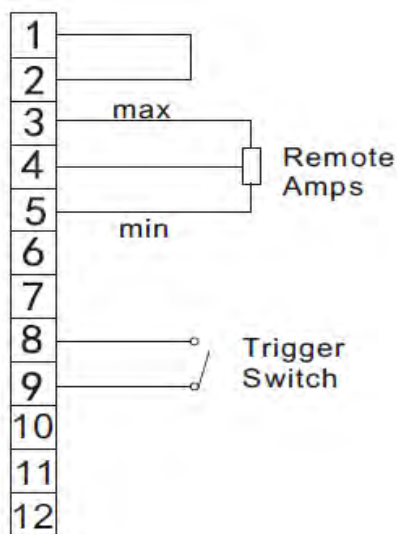
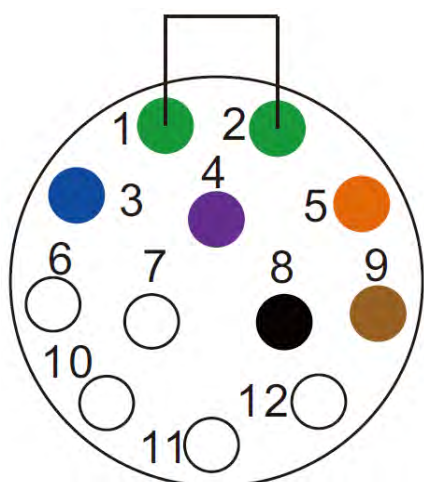
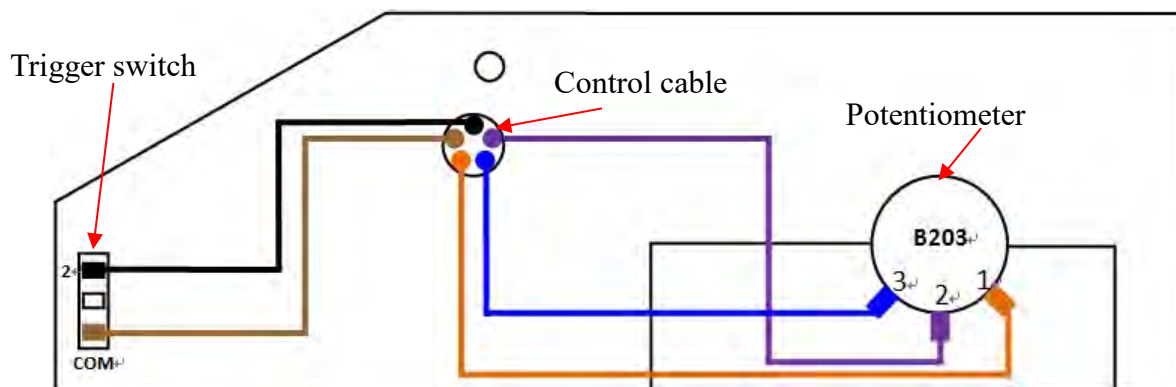

Remote Control Socket

Socket Pin	Function
1	Be shorted with 2
2	Be shorted with 1
3	20k ohm (maximum) connection to 20k ohm remote control potentiometer
4	Wiper arm connection to 20k ohm remote control potentiometer
5	Zero ohm (minimum) connection to 20k ohm remote control potentiometer
6	Not connected
7	Not connected
8	Trigger Switch Input
9	Trigger Switch Input
10	Not connected
11	Not connected
12	Not connected

§4.3 Installation & Operation for MIG Welding

§4.3.1 Set up installation for MIG Welding

- (1) Insert the earth cable plug into the negative socket on the front of the machine and tighten it.
- (2) Plug the welding torch into the MIG torch connection socket on the front panel of the wire feeder, and tighten it.

IMPORTANT : When connecting the torch be sure to tighten the connection. A loose connection can result in the connector arcing and damaging the machine and gun connector.

- (3) Connect the water inlet and outlet pipe of MIG Gun to the water inlet and outlet connectors on the front of the wire feeder .
- (4) Connect the gas line to gas connector on the rear panel of wire feeder. **Check for Leaks!**
- (5) Connect the control cable of wire feeder with the aero socket on the rear panel of welding machine.
- (6) Connect the cable of wire feeder with the positive output of welding machine.
- (7) Connect the water inlet and outlet pipe of wire feeder with the water inlet and outlet connectors on the rear front of cooling water.
- (8) Connect the gas regulator to the Gas Cylinder and connect the gas line to the Gas Regulator.

Check for Leaks!

- (9) Connect the control cable of cooling water with the aero socket on the rear panel of welding machine.
- (10) Connect the power cable of welding machine with the output switch in electric box on site.

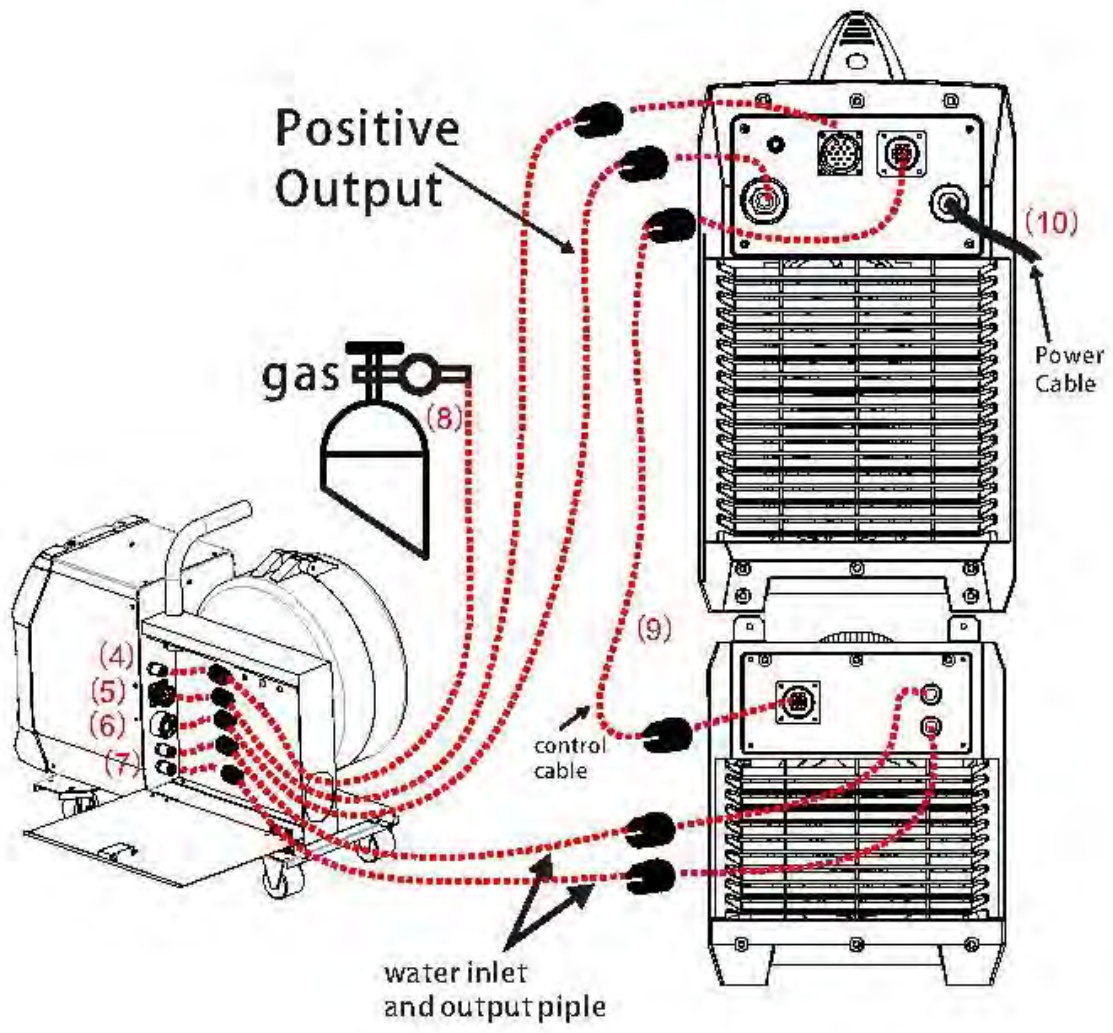
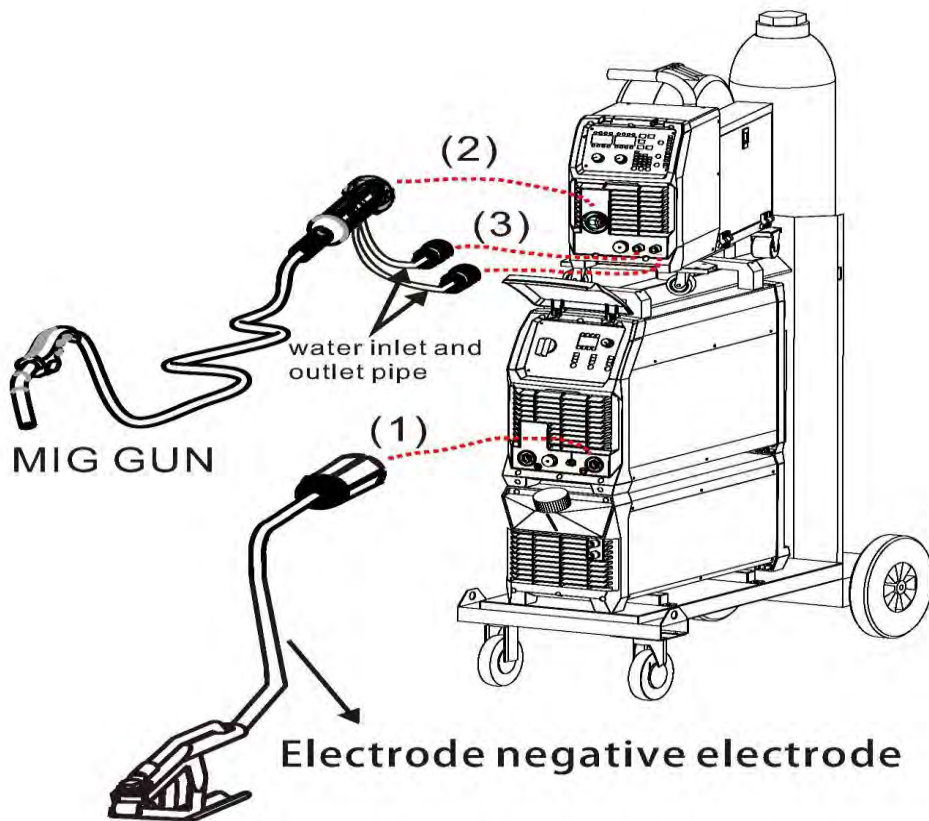

NOTE: Air cooling mode without cooling device, and the water pipe is not needed for the air cooling mode.

- (11) Place the Wire Spool onto the Spool Holder. Snip the wire from the spool being sure to hold the wire to prevent rapid uncoiling. Feed the wire into the wire feeder inlet guide tube through to the drive roller.
- (12) Carefully feed the wire over the drive roller into the outlet guide tube, feed through about 150mm into the torch receptacle. Check that the drive roller size is compatible with the wire diameter, replace the roller if necessary.
- (13) Align the wire into the groove of the drive roller and close down the top roller making sure the wire is in the groove of the bottom drive roller, lock the pressure arm into place. Apply a medium amount of pressure to the drive roller.
- (14) Remove the gas nozzle and contact tip from the torch neck.
- (15) Press and hold the manual wire key to feed the wire through to the torch neck, release the manual wire key when the wire exits the torch neck.
- (16) Fit the correct sized contact tip and feed the wire through it, screw the contact tip into the tip holder of the torch head and nip it up tightly.
- (17) Fit the gas nozzle to the torch head.
- (18) Carefully open the gas cylinder valve and set the required gas flow rate.
- (19) Select 2T/4T/S4T/Spot Weld trigger function.
- (20) Select the required MIG-MAG function, Select program number to suit the wire diameter and gas type being used, it will show on the digital meter .
- (21) Set the required welding parameters to suit the material thickness being welded, it will show on the digital meter .

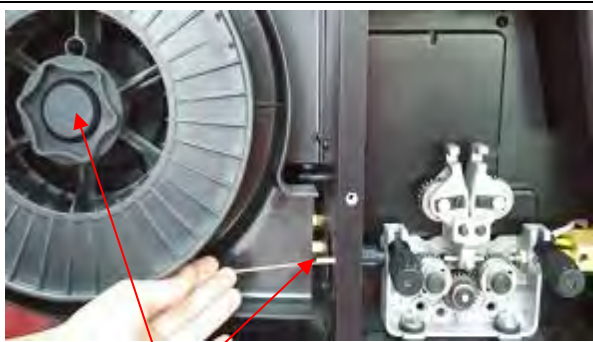

(11) Place wire onto spool holder - (spool retaining nut is left hand thread) Feed the wire through the inlet guide tube on to the drive roller.



(12) Feed wire over the drive roller into the outlet guide tube, Push the wire through approx 150mm.

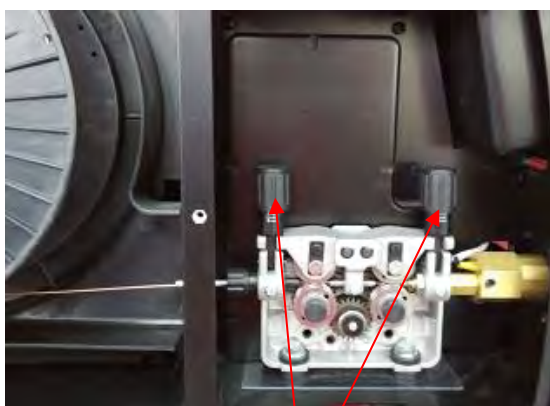

(13) Close down the top roller bracket and clip the pressure arm into place with a medium amount of pressure applied.



(14) Remove the gas nozzle and contact tip from the front end of the mig torch.

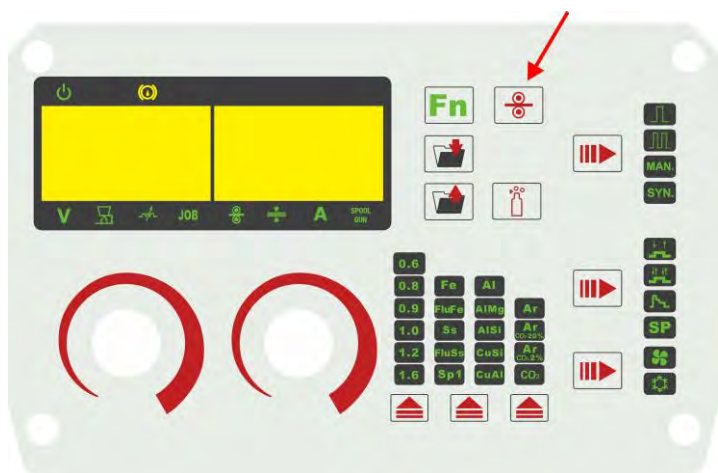

(15) Press and hold the manual wire key to feed the wire down the torch cable through to the torch head.



(16) Fit the correct size contact tip over the wire and fasten tightly into the tip holder.



(17) Fit the gas nozzle to the torch head.

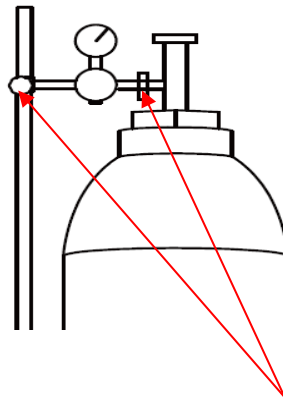

(18) Carefully open the gas cylinder valve and set the required gas flow rate.

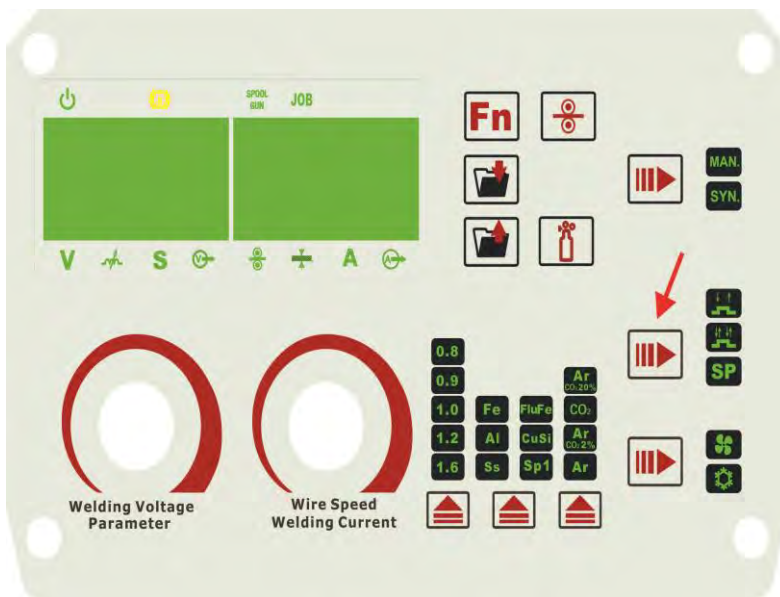

(19) Select torch switch mode 2T/ 4T /Spot Weld

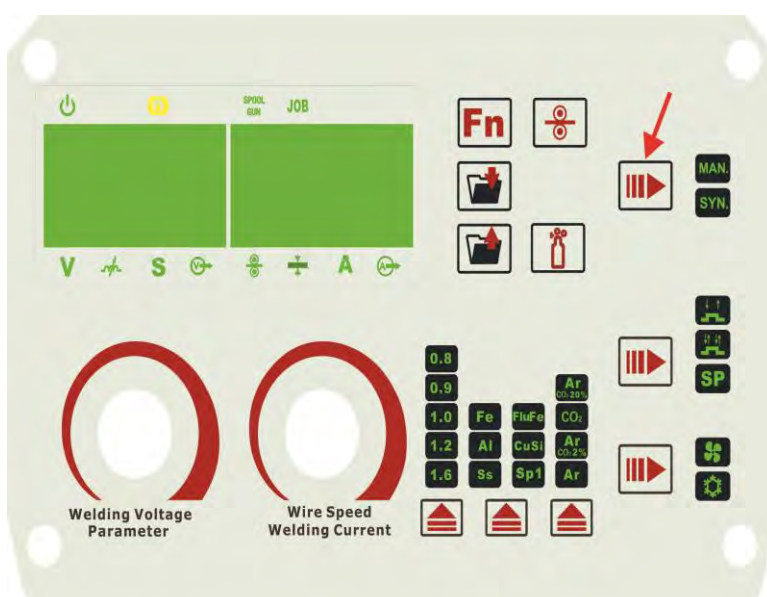

(20) Select your preferred MIG-MAG function.

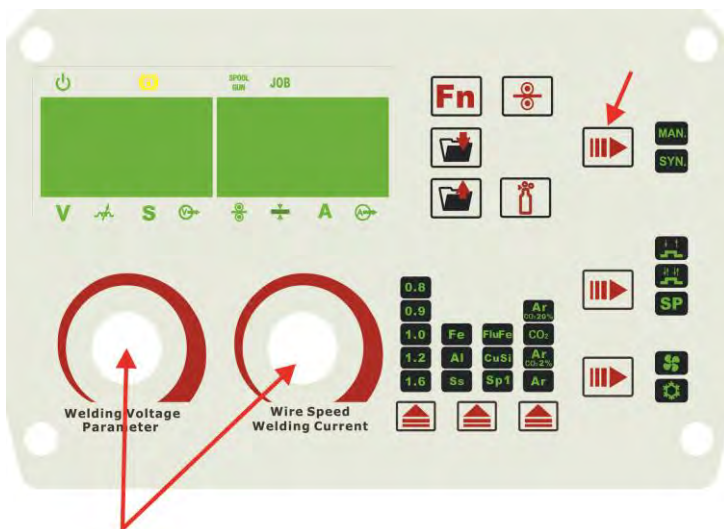

(20) Select program number using the knob , it will show on the digital meter .

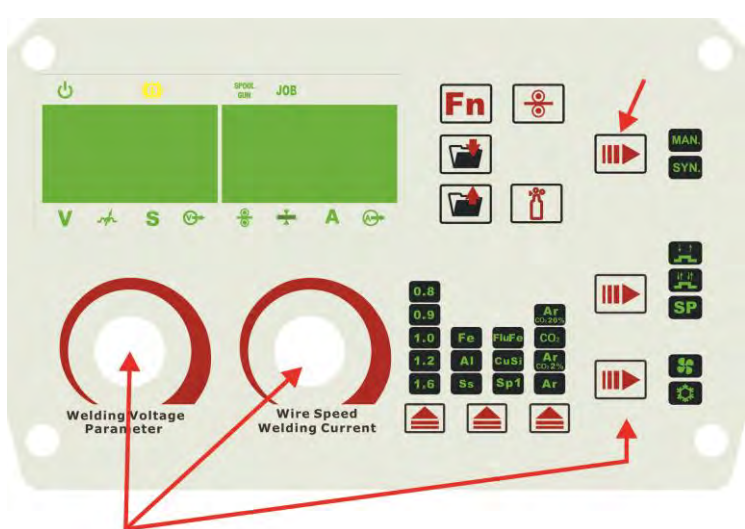

(21) Select the required welding parameters using the knobs.

§4.3.2 Wire Feed Roller Selection

The importance of smooth consistent wire feeding during MIG welding cannot be emphasized enough. Simply put the smoother the wire feed then the better the welding will be.

Feed rollers or drive rollers are used to feed the wire mechanically along the length of the welding gun. Feed rollers are designed to be used for certain types of welding wire and they have different types of grooves machined in them to accommodate the different types of wire. The wire is held in the groove by the top roller of the wire drive unit and is referred to as the pressure roller, pressure is applied by a tension arm that can be adjusted to increase or decrease the pressure as required. The type of wire will determine how much pressure can be applied and what type of drive roller is best suited to obtain optimum wire feed.

Solid Hard Wire - like Steel, Stainless Steel require a drive roller with a V shape groove for optimum grip and drive capability. Solid wires can have more tension applied to the wire from the top pressure roller that holds the wire in the groove and the V shape groove is more suited for this. Solid wires are more forgiving to feed due to their higher cross sectional column strength, they are stiffer and don't bend so easy.

Soft Wire - like Aluminium requires a U shape groove. Aluminium wire has a lot less column strength, can bend easily and is therefore more difficult to feed. Soft wires can easily buckle at the wire feeder where the wire is fed into inlet guide tube of the torch. The U-shaped roller offers more surface area grip and traction to help feed the softer wire. Softer wires also require less tension from the top pressure roller to avoid deforming the shape of the wire, too much tension will push the wire out of shape and cause it to catch in the contact tip.

Flux Core / Gasless Wire - these wires are made up of a thin metal sheath that has fluxig and metal compounds layered onto it and then rolled into a cylinder to form the finished wire. The wire cannot take too much pressure from the top roller as it can be crushed and deformed if too much pressure is applied. A knurled drive roller has been developed and it has small serrations in the groove, the serrations grip the wire and assist to drive it without too much pressure from the top roller. The down side to the knurled wire feed roller on flux cored wire is it will slowly over time bit by bit eat away at the surface of the welding wire, and these small pieces will eventually go down into the liner. This will cause clogging in the liner and added friction that will lead to welding wire feed problems. A U groove wire can also be used for flux core wire without the wire

particles coming of the wire surface. However it is considered that the knurled roller will give a more positive feed of flux core wire without any deformation of the wire shape.

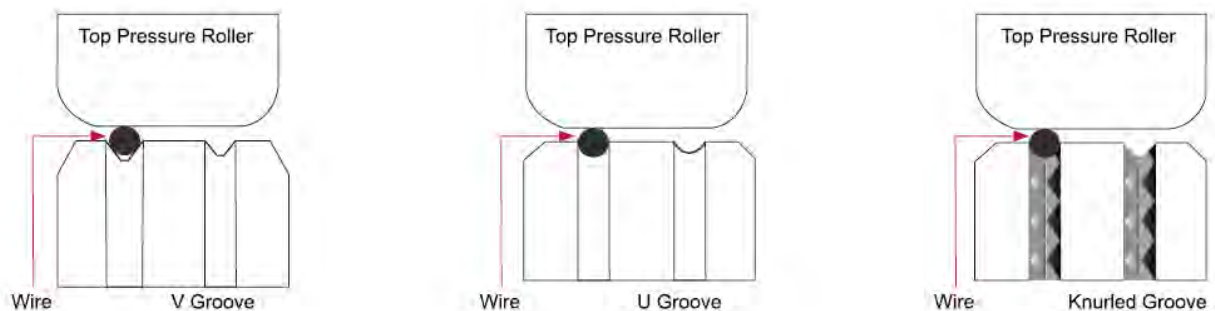

§4.3.3 Wire Installation and Set Up Guide

Again the importance of smooth consistent wire feeding during MIG welding cannot be emphasized enough. The correct installation of the wire spool and the wire into the wire feed unit is critical to achieving an even and consistent wire feed. A high percentage of faults with mig welders emanate from poor set up of the wire into the wire feeder. The guide below will assist in the correct setup of your wire feeder.



(1) Remove the spool retaining nut.



(2) Note the tension spring adjuster and spool locating pin.

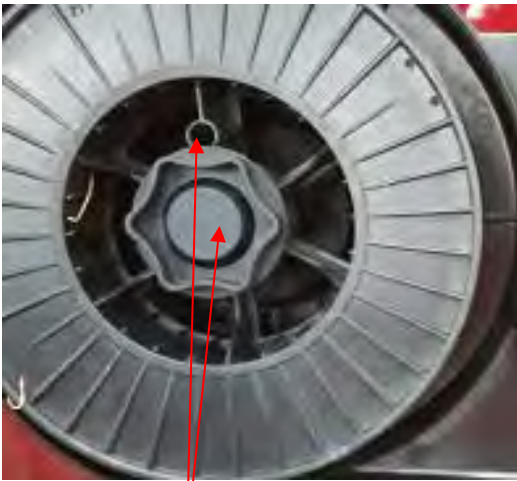

(3) Fit the wire spool onto the spool holder fitting the locating pin into the location hole on the spool. Replace the spool retaining nut tightly.

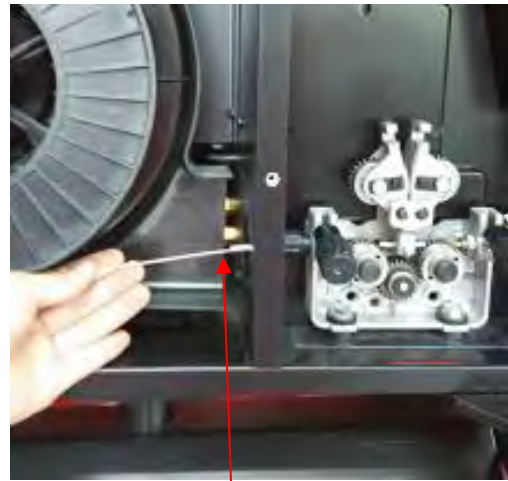

(4) Snip the wire carefully, be sure to hold the wire to prevent the spool uncoiling. Carefully feed the wire into the inlet guide tube of the wire feed unit.



(5) Feed the wire through the drive roller and into the outlet guide tube of the wire feeder.



(6) Lock down the top pressure roller and apply a medium amount of pressure using the tension adjustment knob.



(7) Check that the wire passes through the centre of the outlet guide tube without touching the sides. Loosen the locking screw and then loosen the outlet guide tube retaining nut too make adjustment if required. Carefully retighten the locking nut and screw to hold the new position.



(8) A simple check for the correct drive tension is to bend the end of the wire over hold it about 100mm from your hand and let it run into your hand, it should coil round in your hand without stopping and slipping at the drive rollers, increase the tension if it slips.



(9) The weight and speed of the wire spool turning creates an inertia that can cause the spool to run on and the wire loop over the side of the spool and tangle. if this happens increase the pressure on the tension spring inside the spool holder assembly using the tension adjustment screw.

§4.3.4 MIG Torch Liner Installation

- (1) Lay the torch out straight on the ground and remove the front end parts.
- (2) Remove the liner retaining nut.
- (3) Carefully pull the liner out of the torch cable assembly.
- (4) Select the correct new liner and carefully unravel avoiding putting any kinks in the liner, if you kink the liner it will make it no good and will require replacement.
- (5) Carefully and slowly feed the liner in short forward movements down the cable assembly all the way through and out the torch neck end. Avoid kinking the liner, kinking liner it will make it no good and require replacement.
- (6) Fit the liner retaining nut and screw down only 1/2 way .
- (7) Leaving the torch straight snip the liner approximately 3mm past the end of the torch neck .
- (8) Place the tip holder over the end of the liner and screw into the torch neck nipping it up tight.
- (9) Screw down the liner nut the remaining 1/2 and nip it up tight. This method compresses the liner inside the torch cable assembly preventing it moving during use and ensures good wire feed.



(1) Remove mig torch front end parts.



(2) Remove the liner retaining nut.

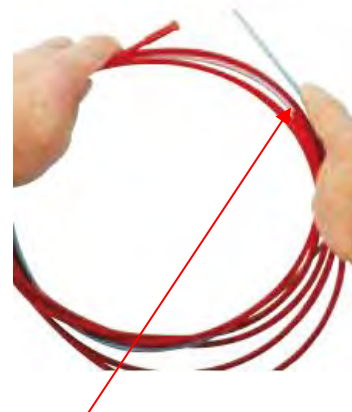

(3) Carefully pull out and completely remove the liner.



(4) Carefully unravel the new liner



(5) Carefully feed in the new liner down the torch lead all the way to exit the torch neck.

(6) Fit the liner retaining nut and screw only 1/2 way down.



(7) Snip the liner off 3mm past the end of the torch neck.



(8) Replace the front end parts.



(9) Fully screw down the liner retaining nut and nip it. up tight.



§4.3.5 MIG Torch Liner Types and Information

MIG Torch Liners

The liner is both one of the simplest and most important components of a MIG gun. Its sole purpose is to guide the welding wire from the wire feeder, through the gun cable and up to the contact tip.

Steel Liners

Most MIG gun liners are made from coiled steel wire also known as piano wire, which provides the liner with good rigidity and flexibility and allows it to guide the welding wire smoothly through the welding cable as it bends and flex during operational use. Steel liners are primarily used for feeding of solid steel wires, other wires such as Aluminium, Silicon Bronze etc will perform better using a teflon or Polyamide line. The internal diameter of the liner is important and relative to the wire diameter being used and will assist in smooth feeding and prevention of the wire kinking and birdnesting at the drive rollers. Also bending the cable too tightly during welding increases the friction between the liner and the welding wire making it more difficult to push the wire through the liner resulting in poor wire feeding, premature liner wear and birdnesting. Dust, grime and metal particles can accumulate inside the liner over time and cause friction and blockages, it is recommended to periodically blow out the liner with compressed air. Small diameter welding wires, 0.6mm through 1.0mm have relatively low columnar strength, and if matched with an oversized liner, can cause the wire to wander or drift within the liner. This in turn leads to poor wire feeding and premature liner failure due to excessive wear. By contrast, larger diameter welding wires, 1.2mm through 2.4mm have much higher columnar strength but it is important to make sure the liner has enough internal diameter clearance. Most manufacturers will produce liners sized to match wire diameters and length of welding torch cable and most are colour coded to suit.

	Steel Liners
Blue-0.6mm-0.8mm	
Red - 0.9mm - 1.2mm	
Yellow - 1.6mm	
Green - 2.0mm - 2.4mm	

Teflon and Polyamide (PA) Liners

Teflon liners are well suited for feeding soft wires with poor column strength like aluminium wires. The interiors of these liners are smooth and provide stable feedability, especially on small diameter welding wire. Teflon can be good for higher heat applications that utilize water-cooled torches and brass neck liners. Teflon has good abrasion resistance characteristics and can be used

with a variety of wire types such as silicon bronze, stainless steel as well as aluminium. A note of caution to carefully inspect the end of the welding wire prior to feeding it down the liner. Sharp edges and burrs can score the inside of the liner and lead to blockages and accelerated wear. Polyamide Liners (PA) are made of carbon infused nylon and are ideal for softer aluminum, copper alloy welding wires and push pull torch applications. These liners are generally fitted with a floating collet to allow the liner to be inserted all the way to the feed rollers.

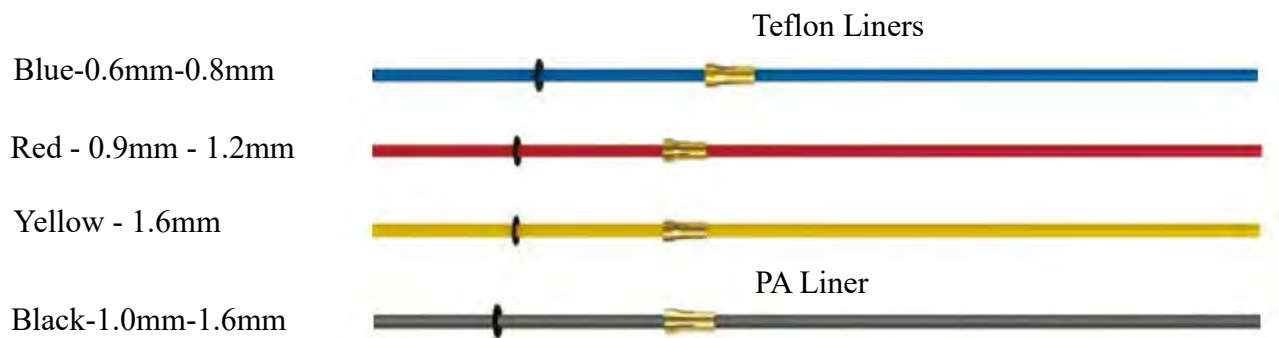

Copper - Brass Neck Liners

For high heat applications fitting brass or copper wound jumper or neck liner on the end of the liner at the neck end will increase the working temperature of the liner as well as improve the electrical conductivity of the welding power transfer to the wire.



§4.3.6 Torch & Wire Feed Set Up for Aluminium Wire

- (1) Lay the torch out straight on the ground and remove the front end parts
- (2) Remove the liner retaining nut.
- (3) Carefully pull the liner out of the torch cable assembly.
- (4) Select a PA or liner and carefully unravel avoiding putting any kinks in the liner.
- (5) Carefully and slowly feed the liner in short forward movements down the cable assembly all the way through and out the torch neck end. Avoid kinking the liner, kinking the liner will ruin it and require replacement.
- (6) Fit the liner retaining nut together with the liner o-ring, Push the liner firmly into the torch lead and tighten the liner retaining nut.
- (7) Leave the liner extending out the end of the torch neck end by 3mm.

- (8) Place the tip holder over the end of the liner and screw into the torch neck nipping it up tight.
- (9) Connect the torch to the machine tighten and secure the torch euro connector to the machine euro connection.
- (10) Install a U groove drive roller of the correct size to match the wire diameter being used.
- (11) Place aluminium wire onto spool holder. Feed the wire through the inlet guide tube on to the drive roller.
- (12) Press and hold the manual wire key to feed the wire down the torch cable through to the torch head.
- (13) Fit an Aluminium contact tip of the correct size to match the wire diameter being used
- (14) Fit the remaining front end parts to the torch neck ready for welding.

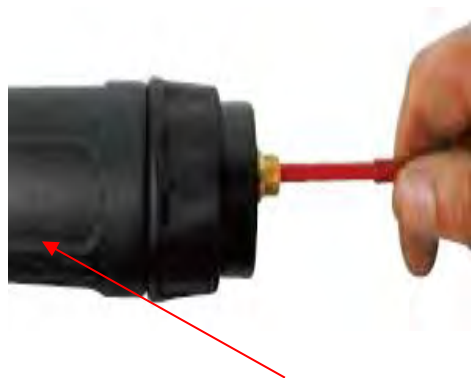

(1) Remove mig torch front end parts.



(2) Remove the liner retaining nut.



(3) Carefully pull out and completely remove the liner.

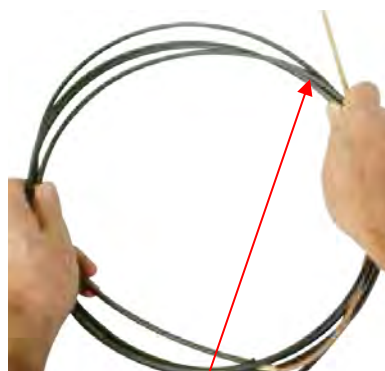

(4) Carefully unravel the new liner.

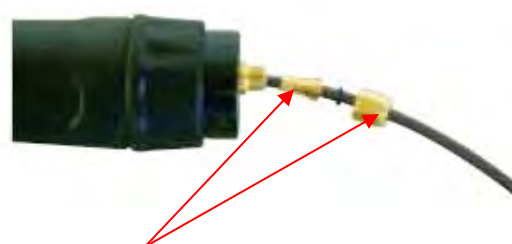

(5) Carefully feed in the new liner in short forward movements down the torch lead all the way to exit the torch neck. Be care-full not to kink the liner.



(6) Push the liner firmly into the torch lead and tighten the liner retaining nut.



(8) Replace the front end parts.



(11) Place aluminium wire onto spool holder. Feed the wire through the inlet guide tube on to the drive roller.



(6) Fit the liner collet, liner O-ring and liner retaining nut.

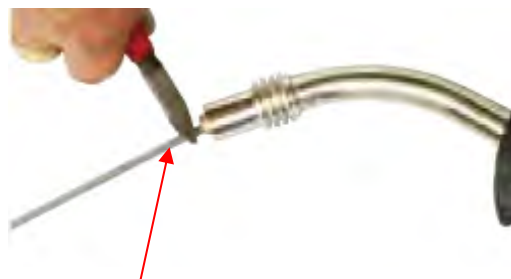

(7) Snip the liner off 3mm past the end of the torch neck.

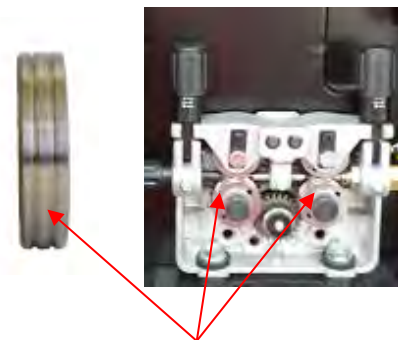

(10) Install a U groove drive roller of the size for the diameter wire being used.

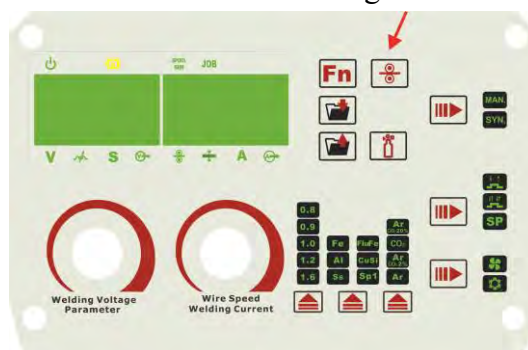

(12) Press and hold the manual wire key to feed the wire down the torch cable through to the torch head.



(13) Fit an Aluminium contact tip of the correct size to match the wire diameter being used.

(14) Fit the remaining front end parts to the torch neck ready for welding.

§4.3.7 Set up installation for Spool Gun

(1) Insert the earth cable plug into the Negative socket on the front of the machine and tighten it.

(2) Connect the Spool Gun to the Mig torch connection socket on the front panel of the wire feeder, and tighten it.

IMPORTANT : When connecting the torch be sure to tighten the connection. A loose connection can result in the connector arcing and damaging the machine and gun connector.

(3) Connect the Spool Gun control cable to the multipin receptacle on the front panel of the wire feeder .

(4) Connect the gas line to gas connector on the rear panel of wire feeder .

(5) Connect the control cable of wire feeder with the aero socket on the rear panel of welding machine.

(6) Connect the cable of wire feeder with the positive output of welding machine.

(7) Connect the gas regulator to the Gas Cylinder and connect the gas line to the Gas Regulator.

(8) Connect the power cable of welding machine with the output switch in electric box on site.

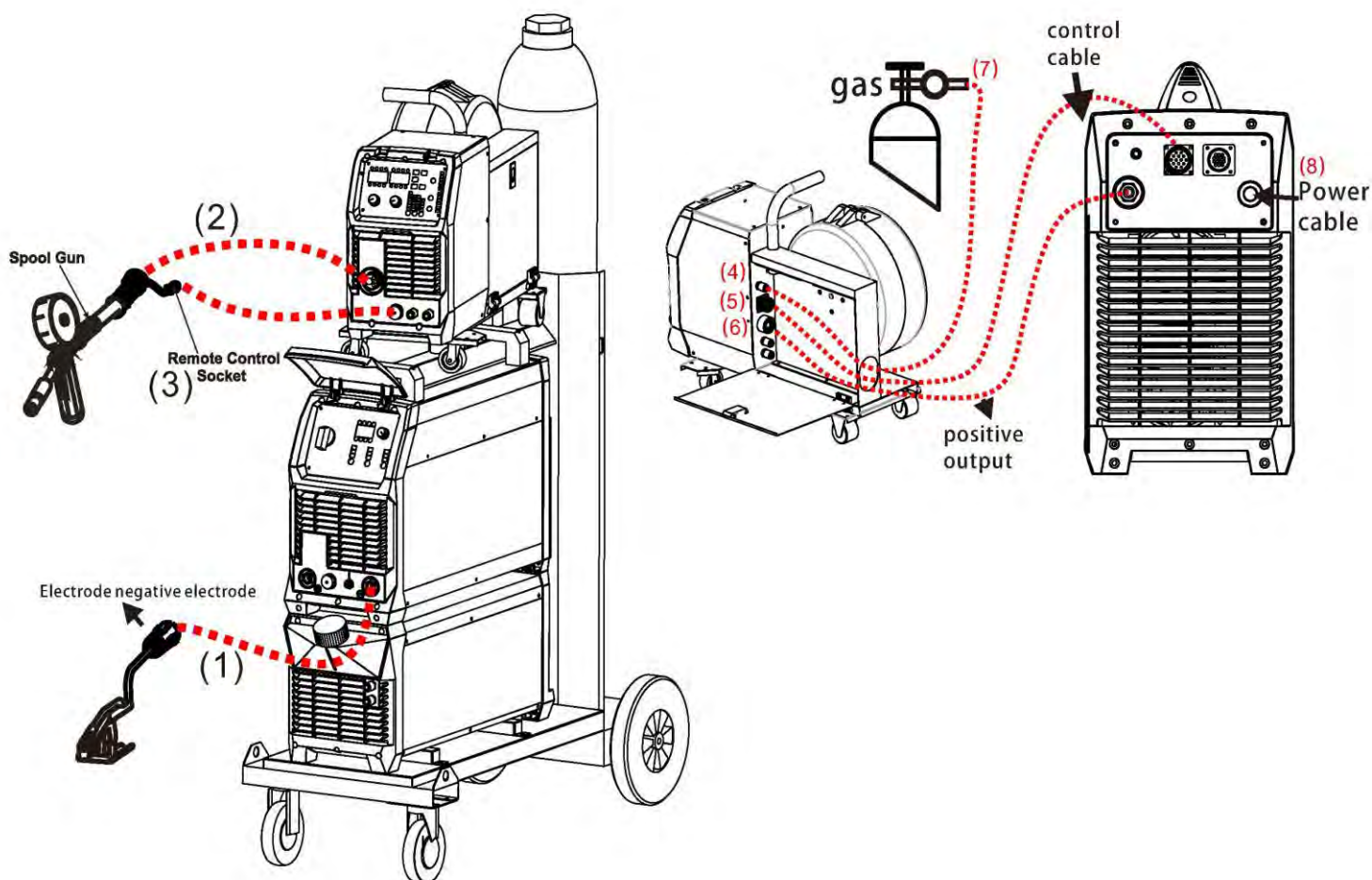

- (9) Select **Spool Gun** using the Function key and Adjustment knobs.
- (10) Take the Spool Gun and remove the spool cover .
- (11) Place the Wire Spool onto the Spool Holder - Hold and snip the wire from the spool being sure to hold the wire to prevent rapid uncoiling.
- (12) Carefully feed the wire through the drive roller into the inlet guide tube. Swing back and clip down the wire tension swing arm.
- (13) Pull the trigger to drive the wire through the neck until it exits the contact tip holder
- (14) Close the wire feed housing cover, ready for welding.
- (15) Carefully open the gas cylinder valve and set the required gas flow rate.
- (16) Set the welding parameters using the knobs.

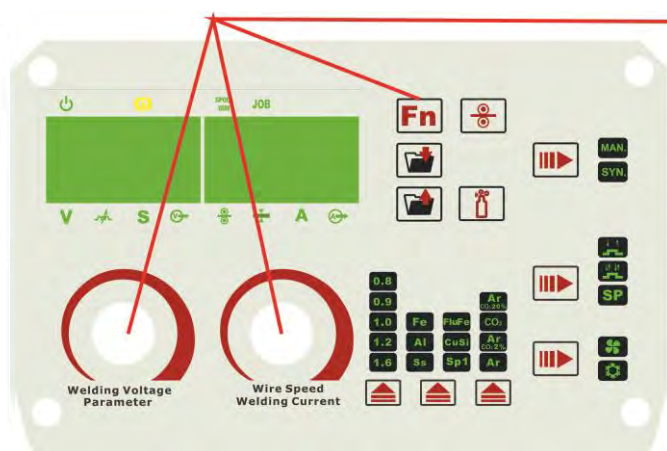

(9) Select **Spool Gun** using the Function key and Adjustment knobs



(10) Remove the spool cover when press the button and lifting off the cover



(11) Place a spool of wire onto the Spool holder.

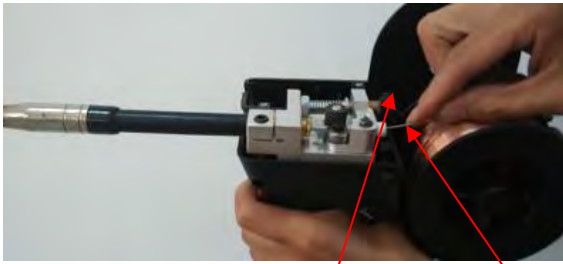

(12) Feed the wire through the drive roller into the inlet guide tube. Swing back and clip down the wire tension swing arm



(13) Pull the trigger to drive the wire through the neck until it exits the contact tip holder.

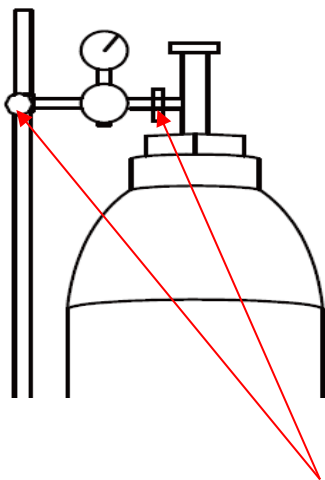

(15) Carefully open the gas cylinder valve and set the required gas flow rate.

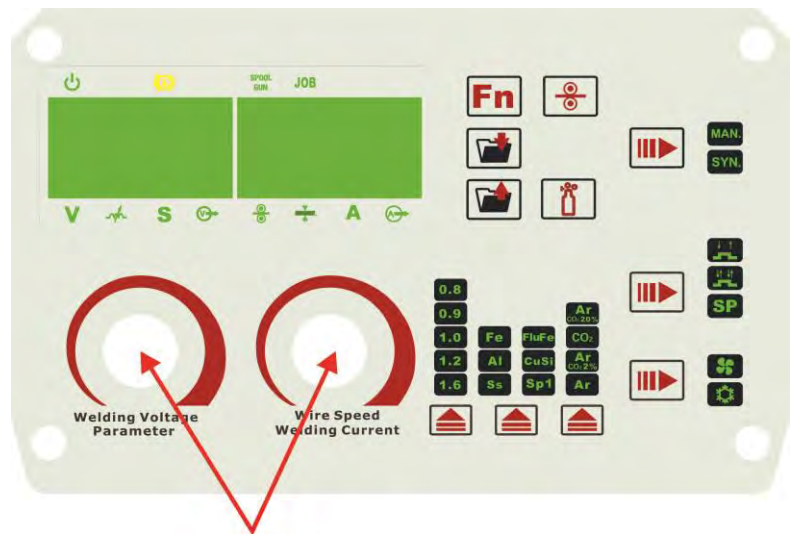

(16) Set welding parameters using the knobs.

§4.3.8 MIG Welding

Definition of MIG Welding

MIG (metal inert gas) welding also known as GMAW (gas metal arc welding) or MAG (metal active gas welding), is a semi-automatic or automatic arc welding process in which a continuous and consumable wire electrode and a shielding gas are fed through a welding gun. A constant voltage, direct current power source is most commonly used with MIG welding. There are four primary methods of metal transfer in MIG welding, called short circuit (also known as dip transfer) globular transfer, spray transfer and pulsed-spray, each of which has distinct properties and corresponding advantages and limitations. To perform MIG welding, the basic necessary equipment is a welding gun, a wire feed unit, a welding power supply, an electrode wire, and a shielding gas supply. Short circuit transfer is the most common used method whereby the wire electrode is fed continuously down the welding torch through to and exiting the contact tip. The

wire touches the work piece and causes a short circuit the wire heats up and begins to form a molten bead, the bead separates from the end of the wire and forms a droplet that is transferred into the weld pool. This process is repeated about 100 times per second, making the arc appear constant to the human eye.

Principles of welding

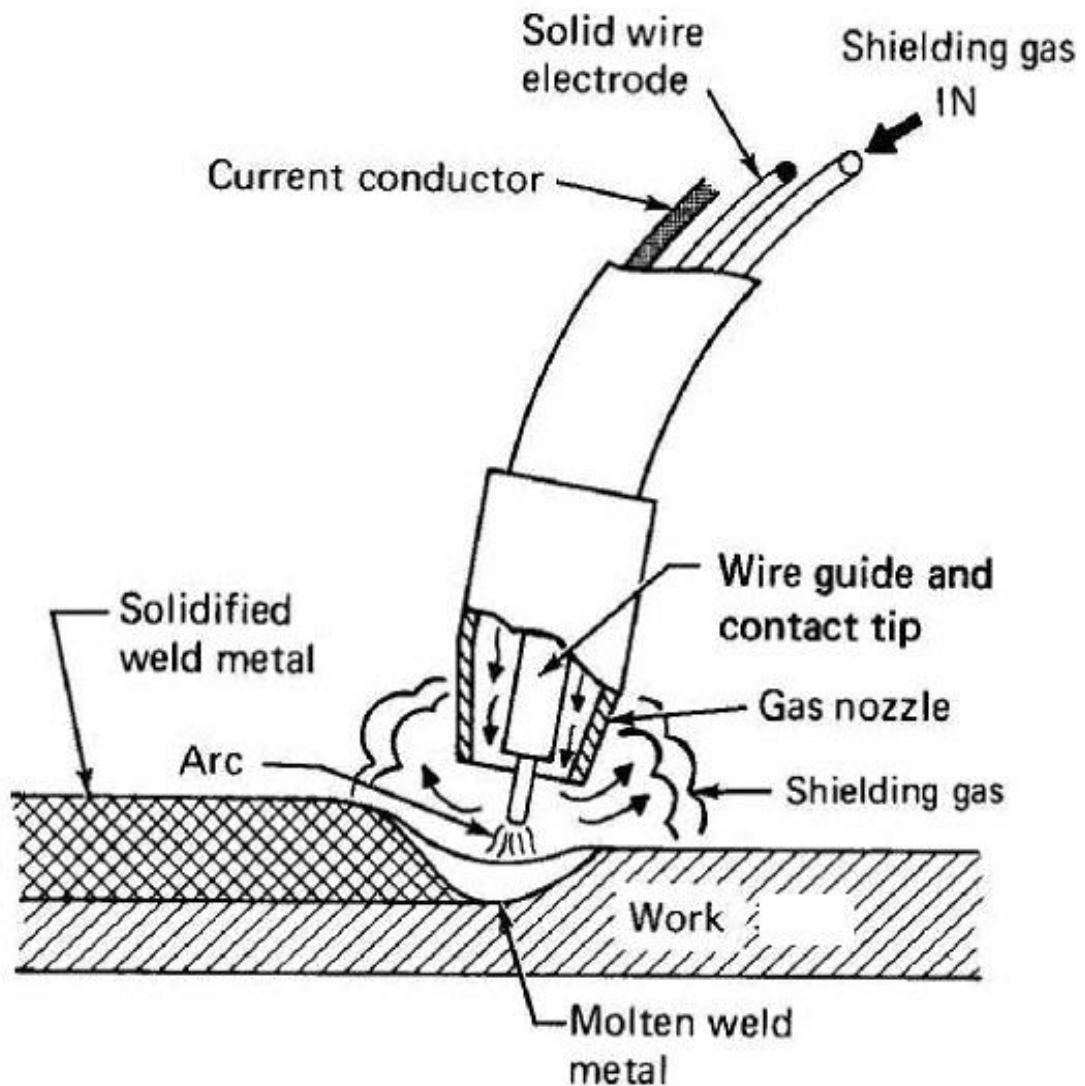

Short Circuit Transfer - Short circuit transfer is the most common used method whereby the wire electrode is fed continuously down the welding torch through to and exiting the contact tip. The wire touches the work piece and causes a short circuit the wire heats up and begins to form a molten bead, the bead separates from the end of the wire and forms a droplet that is transferred into the weld pool. This process is repeated about 100 times per second, making the arc appear constant to the human eye.

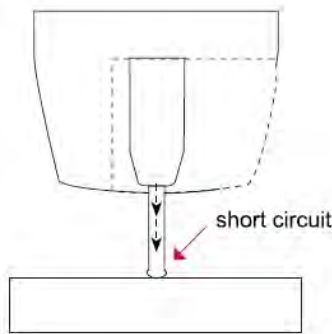

The wire approaches the work piece and touches the work creating a short circuit between the wire and the base metal, because there is no space between the wire and the base metal there is no arc and current flows through the wire.

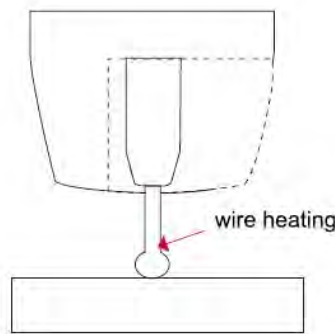

The wire cannot support all the current flow, resistance builds up and the wire becomes hot and weak and begins to melt.

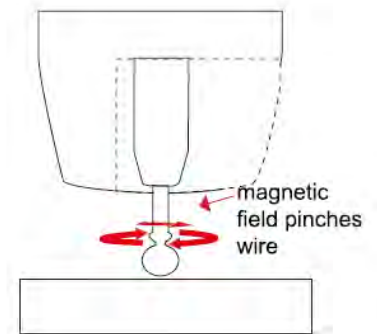

The current flow creates a magnetic field that begins to pinch the melting wire forming it into droplet.

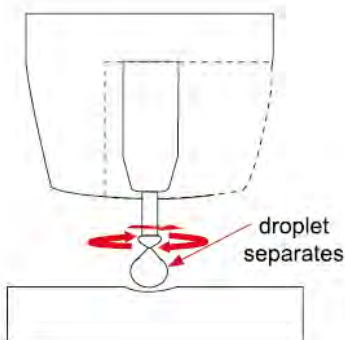

The pinch causes the forming droplet to separate and fall towards the now creating weld pool.

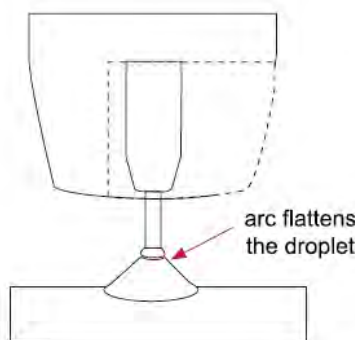

An arc is created at the separation of the droplet and the heat and force of the arc flattens out the droplet into the weld pool. The heat of the arc melts the end of the wire slightly as it feeds towards the base metal.

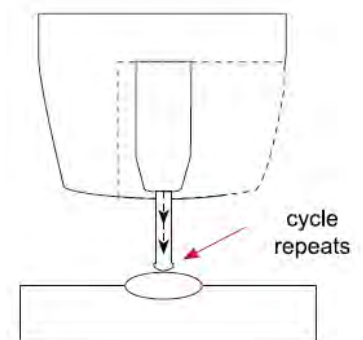

The wire feed speed overcomes the heat of the arc and the wire again approaches the work to short circuit and repeat the cycle.

Basic MIG Welding

Good weld quality and weld profile depends on gun angle, direction of travel, electrode extension (stick out), travel speed, thickness of base metal, wire feed speed and arc voltage. To follow are some basic guides to assist with your setup.

Gun Position - Travel Direction, Work Angle: Gun position or technique usually refers to how

the wire is directed at the base metal, the angle and travel direction chosen. Travel speed and work angle will determine the characteristic of the weld bead profile and degree of weld penetration

Push Technique - The wire is located at the leading edge of the weld pool and pushed towards the un-melted work surface. This technique offers a better view of the weld joint and direction of the wire into the weld joint. Push technique directs the heat away from the weld puddle allowing faster travel speeds providing a flatter weld profile with light penetration - useful for welding thin materials. The welds are wider and flatter allowing for minimal clean up / grinding time.

Perpendicular Technique - The wire is fed directly into the weld, this technique is used primarily for automated situations or when conditions make it necessary. The weld profile is generally higher and a deeper penetration is achieved.

Drag Technique - The gun and wire is dragged away from the weld bead. The arc and heat is concentrated on the weld pool, the base metal receives more heat, deeper melting, more penetration and the weld profile is higher with more build up.

(A) Push Technique

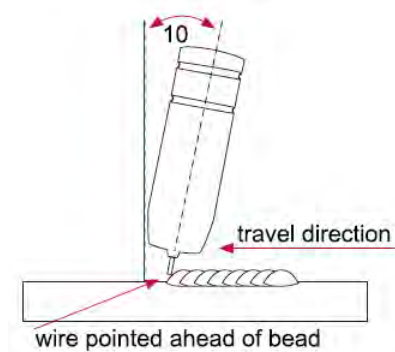

(B) Gun Perpendicular

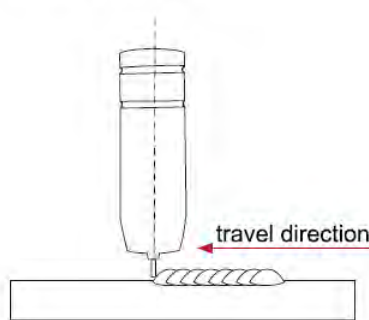

(C) Drag Technique

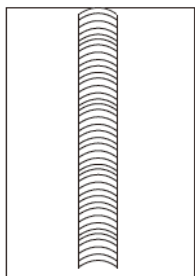
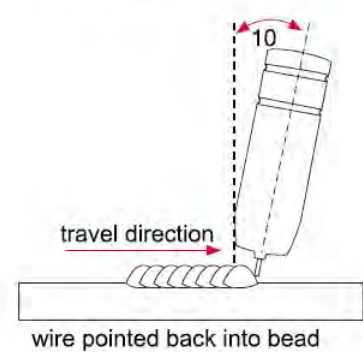

flat even weld profile
light penetration

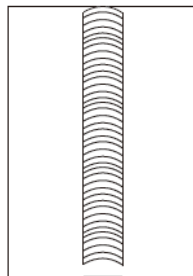

narrower weld profile
even penetration

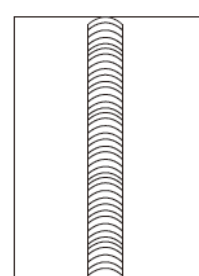

narrow higher
weld profile more
penetration

Travel Angle - Travel angle is the right to left angle relative to the direction of welding. A travel angle of 5°- 15° is ideal and produces a good level of control over the weld pool. A travel angle greater than 20° will give an unstable arc condition with poor weld metal transfer, less penetration, high levels of spatter, poor gas shield and poor quality finished weld.

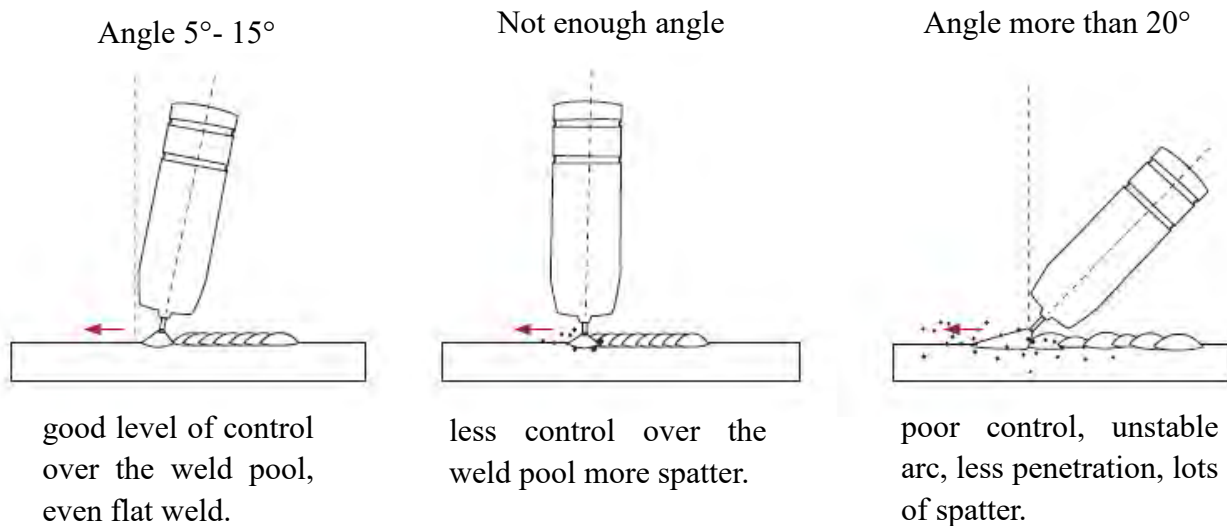

Angle to Work - The work angle is the forward back angle of the gun relative to the work piece. The correct work angle provides good bead shape, prevents undercut, uneven penetration, poor gas shield and poor quality finished weld.

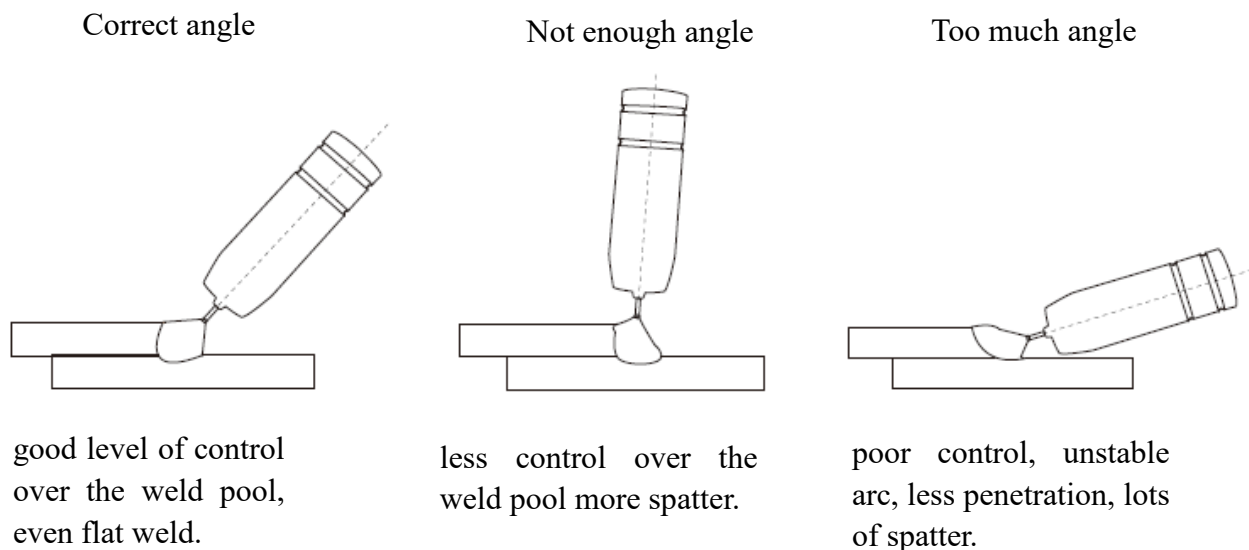

Stick Out- Stick out is the length of the unmelted wire protruding from the end of the contact tip. A constant even stick out of 5-10mm will produce a stable arc, and an even current flow providing good penetration and even fusion. Too short stick out will cause an unstable weld pool, produce

spatter and over heat the contact tip. Too long stick out will cause an unstable arc, lack of penetration, lack of fusion and increase spatter.

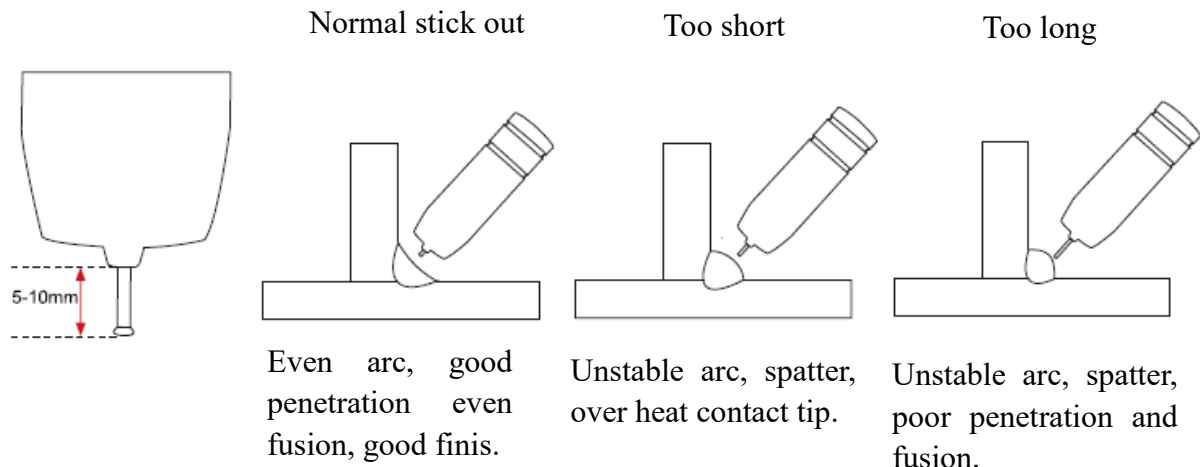

Travel Speed - Travel speed is the rate that the gun is moved along the weld joint and is usually measured in mm per minute. Travel speeds can vary depending on conditions and the welders skill and is limited to the welders ability to control the weld pool. Push technique allows faster travel speeds than Drag technique. Gas flow must also correspond with the travel speed, increasing with faster travel speed and decreasing with slower speed. Travel speed needs to match the amperage and will decrease as the material thickness and amperage increase.

Too Fast Travel Speed - A too fast travel speed produces too little heat per mm of travel resulting in less penetration and reduced weld fusion, the weld bead solidifies very quickly trapping gases inside the weld metal causing porosity. Undercutting of the base metal can also occur and an unfilled groove in the base metal is created when the travel speed is too fast to allow molten metal to flow into the weld crater created by the arc heat.

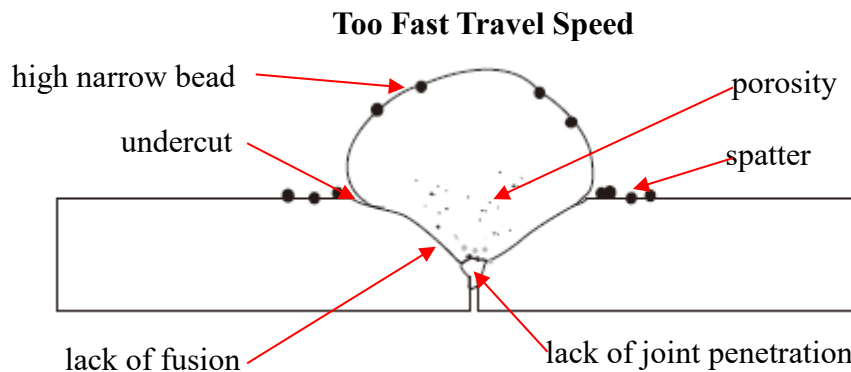

Too Slow Travel Speed - A too slow travel speed produces a large weld with lack of penetration and fusion. The energy from the arc dwells on top of the weld pool rather than penetrating the

base metal. This produces a wider weld bead with more deposited weld metal per mm than is required resulting in a weld deposit of poor quality.

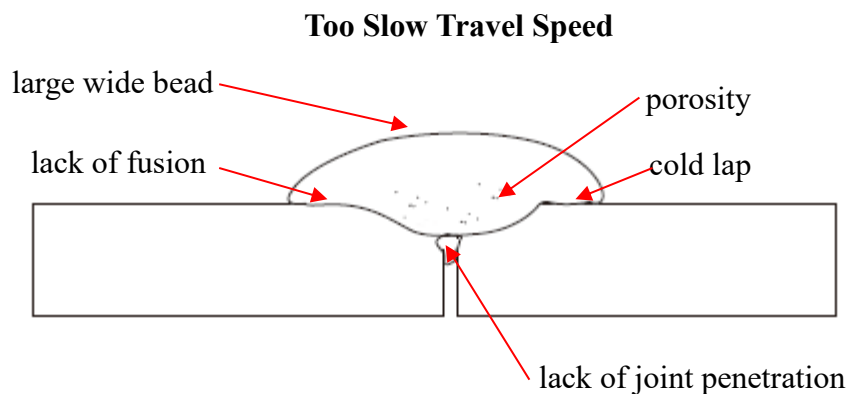

Correct Travel Speed - The correct travel speed keeps the arc at the leading edge of the weld pool allowing the base metal to melt sufficiently to create good penetration, fusion and wetting out of the weld pool producing a weld deposit of good quality.

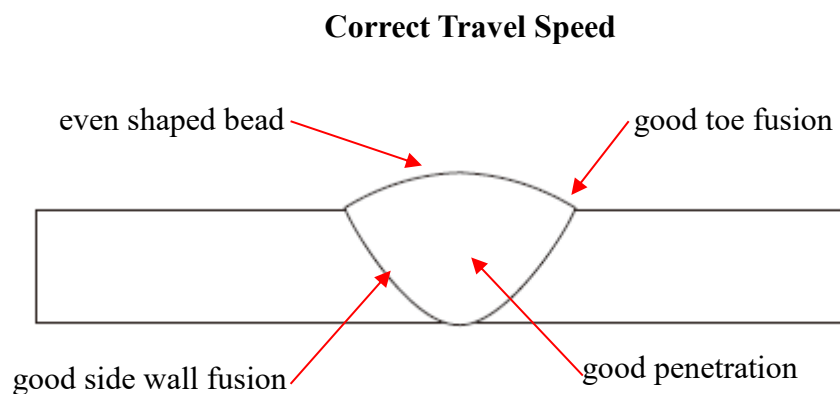

Wire types and sizes - Use the correct wire type for the base metal being welded. Use stainless steel wire for stainless steel, aluminium wires for aluminium and steel wires for steel.

Use a smaller diameter wire for thin base metals. For thicker materials use a larger wire diameter and larger machine, check the recommended welding capability of you machine. As a guide refer to the “Welding Wire Thickness Chart” below.

WELDING WIRE DIAMETER CHART					
MATERIAL THICKNESS	RECOMMENDED WIRE DIAMETERS				
	0.8	0.9	1.0	1.2	1.6
0.8mm					
0.9mm					
1.0mm					
1.2mm					
1.6mm					
2.0mm					
2.5mm					
3.0mm					
4.0mm					
5.0mm					
6.0mm					
8.0mm					
10mm					
14mm					
18mm					
22mm					

For material thickness of 5.0mm and greater, multi-pass runs or a beveled joint design may be required depending on the amperage capability of your machine.

Gas selection - The purpose of the gas in the MIG process is to protect / shield the wire, the arc and the molten weld metal from the atmosphere. Most metals when heated to a molten state will react with the air in the atmosphere, without the protection of the shielding gas the weld produced would contain defects like porosity, lack of fusion and slag inclusions. Additionally some of the gas becomes ionised (electrically charged) and helps the current flow smoothly.

The correct gas flow is also very important in protecting the welding zone from the atmosphere. Too low flow will give inadequate coverage and result in weld defects and unstable arc conditions. Too high flow can cause air to be drawn into the gas column and contaminate the weld zone.

Use the correct shielding gas. Co₂ is good for steel and offers good penetration characteristics, the weld profile is narrower and slightly more raised than the weld profile obtained from Argon Co₂ mixed gas. Argon Co₂ mix gas offers better weld ability for thin metals and has a wider range of setting tolerance on the machine. Argon 80% Co₂ 20% is a good all round mix suitable for most applications.

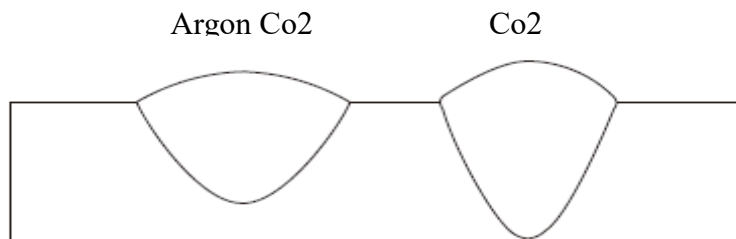

Penetration Pattern for Steel

§4.3.9 MIG Torch /Spool Gun control

Spool Gun

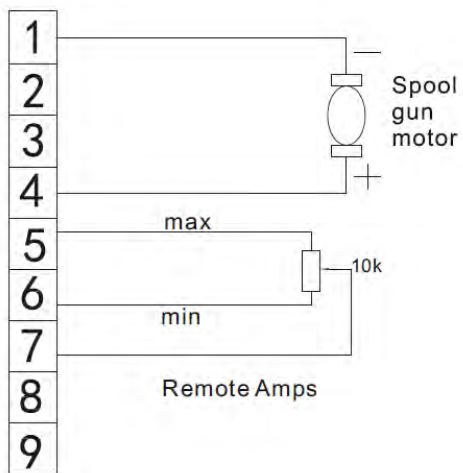
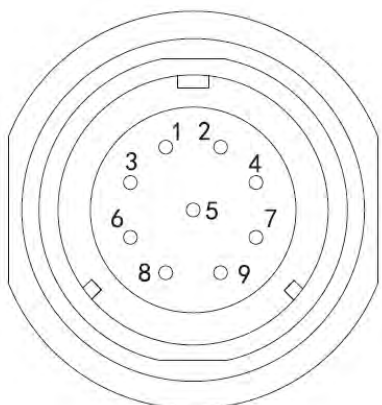
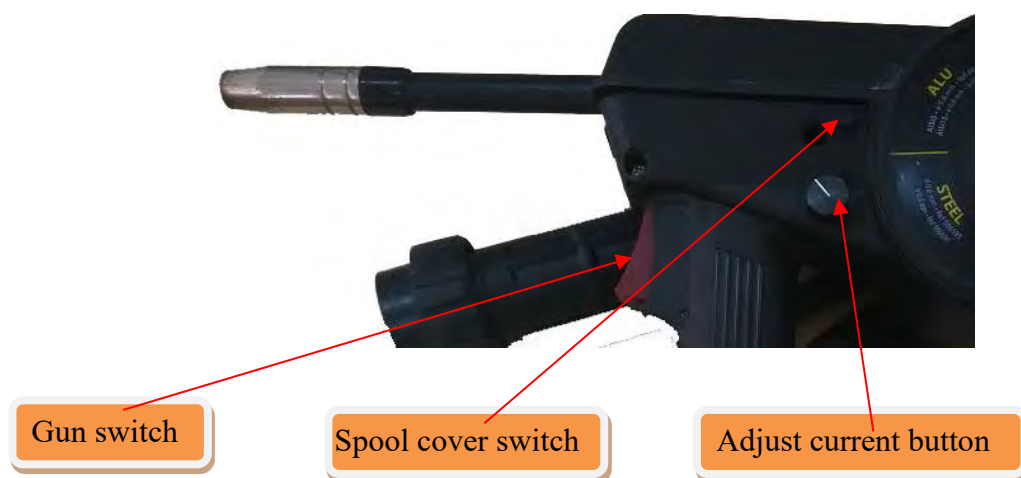

Remote Control Socket

Socket Pin	Function
1	Spool gun motor
2	Not connected

OPERATION

3	Not connected
4	Spool gun motor
5	10k ohm (maximum) connection to 10k ohm remote control potentiometer.
6	Zero ohm (minimum) connection to 10k ohm remote control potentiometer.
7	Wiper arm connection to 10k ohm remote control potentiometer.
8	Not connected
9	Not connected

§4.4 Standard welding programs

DISPLAY	FUNCTION
PrG	PRE GAS
PoG	POST GAS
SFt	SLOW FEED TIME
bub	BURN BACK
SPt	SPOT WELD TIME
Dsl	DOWN SLOPE
SPG	SPOOL GUN

§4.5 Welding parameters

Process reference for CO2 butt welding of low carbon steel solid welding wire

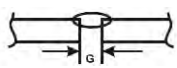
Butt-joint 	Material thickness (MM)	Root gap G (MM)	Wire diameter (MM)	Welding current (A)	Welding voltage (V)	Welding speed (CM/MIN)	Gas-flow rate (L/MIN)
	0.8	0	0.8	60-70	16-16.5	50-60	10
1.0	0	0.8	75-85	17-17.5	50-60	10-15	
1.2	0	0.8	80-90	17-18	50-60	10-15	
2.0	0-0.5	1.0/1.2	110-120	19-19.5	45-50	10-15	
3.2	0-1.5	1.2	130-150	20-23	30-40	10-20	
4.5	0-1.5	1.2	150-180	21-23	30-35	10-20	
6	0	1.2	270-300	27-30	60-70	10-20	
6	1.2-1.5	1.2	230-260	24-26	40-50	15-20	
8	0-1.2	1.2	300-350	30-35	30-40	15-20	
8	0-0.8	1.6	380-420	37-38	40-50	15-20	
12	0-1.2	1.6	420-480	38-41	50-60	15-20	

Process reference for CO₂ corner welding of low carbon steel solid welding wire

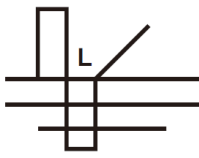
Corner joint 	Material thickness (MM)	Wire diameter (MM)	Welding current (A)	Welding voltage (V)	Welding speed (CM/MIN)	Gas-flow rate (L/MIN)
	1.0	0.8	70-80	17-18	50-60	10-15
	1.2	1.0	85-90	18-19	50-60	10-15
	1.6	1.0/1.2	100-110	18-19.5	50-60	10-15
	1.6	1.2	120-130	19-20	40-50	10-20
	2.0	1.0/1.2	115-125	19.5-20	50-60	10-15
	3.2	1.0/1.2	150-170	21-22	45-50	15-20
	3.2	1.2	200-250	24-26	45-60	10-20
	4.5	1.0/1.2	180-200	23-24	40-45	15-20
	4.5	1.2	200-250	24-26	40-50	15-20
	6	1.2	220-250	25-27	35-45	15-20
	6	1.2	270-300	28-31	60-70	15-20
	8	1.2	270-300	28-31	60-70	15-20
	8	1.2	260-300	26-32	25-35	15-20
	8	1.6	300-330	25-26	30-35	15-20
	12	1.2	260-300	26-32	25-35	15-20
	12	1.6	300-330	25-26	30-35	15-20
16	1.6	340-350	27-28	35-40	15-20	
19	1.6	360-370	27-28	30-35	15-20	

Low carbon steel, stainless steel pulse MAG welding process reference

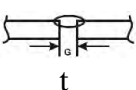
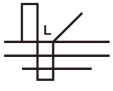
Welding position	Material thickness (MM)	Wire diameter (MM)	Welding current (A)	Welding voltage (V)	Welding speed (CM/MIN)	Nozzle and workpiece spacing (MM)	Gas-flow rate (L/MIN)
Butt-joint 	1.6	1.0	80-100	19-21	40-50	12-15	10-15
	2.0	1.0	90-100	19-21	40-50	13-16	13-15
	3.2	1.2	150-170	22-25	40-50	14-17	15-17
	4.5	1.2	150-180	24-26	30-40	14-17	15-17
	6.0	1.2	270-300	28-31	60-70	17-22	18-22
	8.0	1.6	300-350	39-34	35-45	20-24	18-22
	10.0	1.6	330-380	30-36	35-45	20-24	18-22
Corner joint 	1.6	1.0	90-130	21-25	40-50	13-16	10-15
	2.0	1.0	100-150	22-26	35-45	13-16	13-15
	3.2	1.2	160-200	23-26	40-50	13-17	13-15
	4.5	1.2	200-240	24-28	45-55	15-20	15-17
	6.0	1.2	270-300	28-31	60-70	18-22	18-22
	8.0	1.6	280-320	27-31	45-60	18-22	18-22
	10.0	1.6	330-380	30-36	40-55	20-24	18-22

Welding process of aluminum alloy pulse MIG

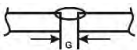
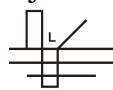
Welding position	Material thickness (MM)	Wire diameter (MM)	Welding current (A)	Welding voltage (V)	Welding speed (CM/MIN)	Nozzle and workpiece spacing(MM)	Gas-flow rate (L/MIN)
 Butt-joint	1.5	1.0	60-80	16-18	60-80	12-15	15-20
	2.0	1.0	70-80	17-18	40-50	15	15-20
	3.0	1.2	80-100	17-20	40-50	14-17	15-20
	4.0	1.2	90-120	18-21	40-50	14-17	15-20
	6.0	1.2	150-180	20-23	40-50	17-22	18-22
	4.0	1.2	160-210	22-25	60-90	15-20	19-20
	4.0	1.6	170-200	20-21	60-90	15-20	19-20
	6.0	1.2	200-230	24-27	40-50	17-22	20-24
	6.0	1.6	200-240	21-23	40-50	17-22	20-24
	8.0	1.6	240-270	24-27	45-55	17-22	20-24
	12.0	1.6	270-330	27-35	55-60	17-22	20-24
	16.0	1.6	330-400	27-35	55-60	17-22	20-24
 Corner joint	1.5	1.0	60-80	16-18	60-80	13-16	15-20
	2.0	1.0	100-150	22-26	35-45	13-16	15-20
	3.0	1.2	100-120	19-21	40-60	13-17	15-20
	4.0	1.2	120-150	20-22	50-70	15-20	15-20
	6.0	1.2	150-180	20-23	50-70	18-22	18-22
	4.0	1.2	180-210	21-24	35-50	18-22	16-18
	4.0	1.6	180-210	18-20	35-45	18-22	18-22
	6.0	1.2	220-250	24-25	50-60	18-22	16-24
	6.0	1.6	220-240	20-24	37-50	18-22	16-24
	8.0	1.6	250-300	25-26	60-65	18-22	16-24
	12.0	1.6	300-400	26-28	65-75	18-22	16-24

§4.6 Operation environment

- ▲ Height above sea level ≤ 1000 M
- ▲ Operation temperature range $-10 \sim +40^{\circ}\text{C}$
- ▲ Air relative humidity is below 90 % (20°C)
- ▲ Preferable site the machine some angles above the floor level, the maximum angle does not exceed 15°C .
- ▲ Protect the machine against heavy rain AND against direct sunshine.
- ▲ The content of dust, acid, corrosive gas in the surrounding air or substance cannot exceed normal standard.
- ▲ Take care that there is sufficient ventilation during welding. There must be at least 30cm free distance between the machine and wall.

§4.7 Operation Notices

- ▲ Read Section §1 carefully before starting to use this equipment.
- ▲ Connect the ground wire with the machine directly.
- ▲ Ensure that the input is three-phase: 50/60Hz, 380V \pm 10%.
- ▲ Before operation, none concerned people should not be around the working area and especially children. Do not watch the arc in unprotected eyes.
- ▲ Ensure good ventilation of the machine to improve Duty Cycle.
- ▲ Turn off the engine when the operation finished for energy consumption efficiency.
- ▲ When power switch shuts off protectively because of failure. Don't restart it until problem is resolved. Otherwise, the range of problem will be extended.
- ▲ In case of problems, contact your local dealer if no authorized maintenance staff is available!

§5 Welding trouble shooting

§5.1 MIG welding trouble shooting

The following chart addresses some of the common problems of MIG welding. In all cases of equipment malfunction, the manufacturer's recommendations should be strictly adhered to and followed.

NO.	Trouble	Possible Reason	Suggested Remedy
1	Excessive Spatter	Wire feed speed set too high	Select lower wire feed speed
		Voltage too high	Select a lower voltage setting
		Wrong polarity set	select the correct polarity for the wire being used - see machine setup guide
		Stick out too long	Bring the torch closer to the work
		Contaminated base metal	Remove materials like paint, grease, oil, and dirt, including mill scale from base metal
		Contaminated mig wire	Use clean dry rust free wire. Do not lubricate the wire with oil, grease etc
		Inadequate gas flow or too much gas flow	Check the gas is connected, check hoses, gas valve and torch are not restricted. Set the gas flow between 6-12 l/min flow rate. Check hoses and fittings for holes, leaks Protect the welding zone from wind and drafts

2	Porosity - small cavities or holes resulting from gas pockets in weld metal.	Wrong gas	Check that the correct gas is being used
		Inadequate gas flow or too much gas flow	Check the gas is connected, check hoses, gas valve and torch are not restricted. Set the gas flow between 10 - 15 l/min flow rate. Check hoses and fittings for holes, leaks etc .Protect the welding zone from wind and drafts
		Moisture on the base metal	Remove all moisture from base metal before welding
		Contaminated base metal	Remove materials like paint, grease, oil, and dirt, including mill scale from base metal
		Contaminated mig wire	Use clean dry rust free wire. Do not lubricate the wire with oil, grease etc
		Gas nozzle clogged with spatter, worn or out of shape	Clean or replace the gas nozzle
		Missing or damaged gas diffuser	Replace the gas diffuser
		Mig torch euro connect o-ring missing or damaged	Check and replace the o-ring
3	Wire stubbing during welding	Holding the torch too far away	Bring the torch closer to the work and maintain stick out of 5-10mm
		Welding voltage set too low	Increase the voltage
		Wire Speed set too high	Decrease the wire feed speed
4	Lack of Fusion – failure of weld metal to fuse completely with base metal or a preceding weld bead.	Contaminated base metal	Remove materials like paint, grease, oil, and dirt, including mill scale from base metal
		Not enough heat input	Select a higher voltage range and /or adjust the wire speed to suit
		Improper welding technique	Keep the arc at the leading edge of the weld pool. Gun angle to work should be between 5 & 15° Direct the arc at the weld joint Adjust work angle or widen groove to access bottom during welding Momentarily hold arc on side walls if using weaving technique

5	Excessive Penetration – weld metal melting through base metal	Too much heat	Select a lower voltage range and /or adjust the wire speed to suit Increase travel speed
6	Lack of Penetration – shallow fusion between weld metal and base metal	Poor in incorrect joint preparation	Material too thick. Joint preparation and design needs to allow access to bottom of groove while maintaining proper welding wire extension and arc characteristics Keep the arc at the leading edge of the weld pool and maintain the gun angle at 5 & 15° keeping the stick out between 5-10mm
		Not enough heat input	Select a higher voltage range and /or adjust the wire speed to suit Reduce travel speed
		Contaminated base metal	Remove materials like paint, grease, oil, and dirt, including mill scale from base metal

§5.2 MIG wire feed trouble shooting

The following chart addresses some of the common WIRE FEED problems during MIG welding. In all cases of equipment malfunction, the manufacturer’s recommendations should be strictly adhered to and followed.

NO.	Trouble	Possible Reason	Suggested Remedy
1	No wire feed	Wrong mode selected	Check that the TIG/MMA/MIG selector switch set to MIG position
		Wrong torch selector switch	Check that the Wire Feeder /Spool Gun selector switch is set to Wire Feeder position for MIG welding and Spool Gun when using the Spool gun

2	Inconsistent / interrupted wire feed	Adjusting wrong dial	Be sure to adjust the wire feed and voltage dials for MIG welding. The amperage dial is for MMA and TIG welding mode
		Wrong polarity selected	Select the correct polarity for the wire being used - see machine setup guide
		Incorrect wire speed setting	Adjust the wire feed speed
		Voltage setting incorrect	Adjust the voltage setting
		Mig torch lead too long	Small diameter wires and soft wires like aluminium don't feed well through long torch leads - replace the torch with a lesser length torch
		Mig torch lead kinked or too sharp angle being held	Remove the kink, reduce the angle or bend
		Contact tip worn, wrong size, wrong type	Replace the tip with correct size and type
		Liner worn or clogged (the most common causes of bad feeding)	Try to clear the liner by blowing out with compressed air as a temporary cure, it is recommended to replace the liner
		Wrong size liner	Install the correct size liner
		Blocked or worn inlet guide tube	Clear or replace the inlet guide tube
		Wire misaligned in drive roller groove	Locate the wire into the groove of the drive roller
		Incorrect drive roller size	Fit the correct size drive roller eg; 0.8mm wire requires 0.8mm drive roller
		Wrong type of drive roller selected	Fit the correct type roller (e.g. knurled rollers needed for flux cored wires)
		Worn drive rollers	Replace the drive rollers
		Drive roller pressure too high	Can flatten the wire electrode causing it to lodge in the contact tip - reduce the drive roller pressure
		Too much tension on wire spool hub	Reduce the spool hub brake tension
		Wire crossed over on the spool or tangled	Remove the spool untangle the wire or replace the wire
		Contaminated mig wire	Use clean dry rust free wire. Do not lubricate the wire with oil, grease etc

§5.3 DC TIG welding trouble shooting

The following chart addresses some of the common problems of DC TIG welding. In all cases of equipment malfunction, the manufacturer's recommendations should be strictly adhered to and followed.

NO.	Trouble	Possible Reason	Suggested Remedy
1	Tungsten burning away quickly	Incorrect Gas or No Gas	Use pure Argon. Check cylinder has gas, connected, turned on and torch valve is open
		Inadequate gas flow	Check the gas is connected, check hoses, gas valve and torch are not restricted.
		Back cap not fitted correctly	Make sure the torch back cap is fitted so that the o-ring is inside the torch body
		Torch connected to DC +	Connect the torch to the DC- output terminal
		Incorrect tungsten being used	Check and change the tungsten type if necessary
		Tungsten being oxidised after weld is finished	Keep shielding gas flowing 10–15 seconds after arc stoppage. 1 second for each 10amps of weld current.
2	Contaminated tungsten	Touching tungsten into the weld pool	Keep tungsten from contacting weld puddle. Raise the torch so that the tungsten is off of the work piece 2 - 5mm
		Touching the filler wire to the tungsten	Keep the filler wire from touching the tungsten during welding, feed the filler wire into the leading edge of the weld pool in front of the tungsten
3	Porosity - poor weld appearance and colour	Wrong gas / poor gas flow /gas leak	Use pure argon. Gas is connected, check hoses, gas valve and torch are not restricted. Set the gas flow between 6-12 l/min. Check hoses and fittings for holes, leaks et
		Contaminated base metal	Remove moisture and materials like paint, grease, oil, and dirt from base metal
		Contaminated filler wire	Remove all grease, oil, or moisture from filler metal
		Incorrect filler wire	Check the filler wire and change if necessary
4	Yellowish residue / smoke on the alumina nozzle & discoloured tungsten	Incorrect Gas	Use pure Argon gas
		Inadequate gas flow	Set the gas flow between 10 - 15 l/min flow rate
		Alumina gas nozzle too small	Increase the size of the alumina gas nozzle

5	Unstable Arc during DC welding	Torch connected to DC +	Connect the torch to the DC- output terminal
		Contaminated base metal	Remove materials like paint, grease, oil, and dirt, including mill scale from base metal.
		Tungsten is contaminated	Remove 10mm of contaminated tungsten and re grind the tungsten
		Arc length too long	Lower torch so that the tungsten is off of the work piece 2 - 5mm
6	Arc wanders during DC welding	Poor gas flow	Check and set the gas flow between 10 - 15 l/min flow rate
		Incorrect arc length	Lower torch so that the tungsten is off of the work piece 2 - 5mm
		Tungsten incorrect or in poor condition	Check that correct type of tungsten is being used. Remove 10mm from the weld end of the tungsten and re sharpen the tungsten
		Poorly prepared tungsten	Grind marks should run lengthwise with tungsten, not circular. Use proper grinding method and wheel.
		Contaminated base metal or filler wire	Remove contaminating materials like paint, grease, oil, and dirt, including mill scale from base metal. Remove all grease, oil, or moisture from filler metal
7	Arc difficult to start or will not start DC welding	Incorrect machine set up	Check machine set up is correct
		No gas, incorrect gas flow	Check the gas is connected and cylinder valve open, check hoses, gas valve and torch are not restricted. Set the gas flow between 10 - 15 l/min flow rate
		Incorrect tungsten size or type	Check and change the size and or the tungsten if required
		Loose connection	Check all connectors and tighten
		Earth clamp not connected to work	Connect the earth clamp directly to the work piece wherever possible

§5.4 MMA welding trouble shooting

The following chart addresses some of the common problems of MMA welding. In all cases of equipment malfunction, the manufacturer's recommendations should be strictly adhered to and followed.

NO.	Trouble	Possible Reason	Suggested Remedy
1	No arc	Incomplete welding circuit	Check earth lead is connected. Check all cable connections.
		Wrong mode selected	Check the MMA selector switch is selected
		No power supply	Check that the machine is switched on and has a power supply
2	Porosity – small cavities or holes resulting from gas pockets in weld metal	Arc length too long	Shorten the arc length
		Work piece dirty, contaminated or moisture	Remove moisture and materials like paint, grease, oil, and dirt, including mill scale from base metal
		Damp electrodes	Use only dry electrodes
3	Excessive Spatter	Amperage too high	Decrease the amperage or choose a larger electrode
		Arc length too long	Shorten the arc length
4	Weld sits on top, lack of fusion	Insufficient heat input	Increase the amperage or choose a larger electrode
		Work piece dirty, contaminated or moisture	Remove moisture and materials like paint, grease, oil, and dirt, including mill scale from base metal
		Poor welding technique	Use the correct welding technique or seek assistance for the correct technique
5	Lack of penetration	Insufficient heat input	Increase the amperage or choose a larger electrode
		Poor welding technique	Use the correct welding technique or seek assistance for the correct technique
		Poor joint preparation	Check the joint design and fit up, make sure the material is not too thick. Seek assistance for the correct joint design and fit up
6	Excessive penetration - burn through	Excessive heat input	Reduce the amperage or use a smaller electrode
		Incorrect travel speed	Try increasing the weld travel speed

THANK YOU FOR USING OUR PRODUCTS

7	Uneven weld appearance	Unsteady hand, wavering hand	Use two hands where possible to steady up, practise your technique
8	Distortion – movement of base metal during welding	Excessive heat input	Reduce the amperage or use a smaller electrode
		Poor welding technique	Use the correct welding technique or seek assistance for the correct technique
		Poor joint preparation and or joint design	Check the joint design and fit up, make sure the material is not too thick. Seek assistance for the correct joint design and fit up
9	Electrode welds with different or unusual arc characteristic	Incorrect polarity	Change the polarity, check the electrode manufacturer for correct polarity

§6 Maintenance & Troubleshooting

§6.1 Maintenance

In order to guarantee safe and proper operation of welding machines, they must be maintained regularly. Let customers understand the maintenance procedure of welding machines. Enable customers to carry on simple examination and inspections. Do your best to reduce the fault rate and repair times of welding machines to lengthen service life of arc welding machine. Maintenance items in detail are in the following table.

- **Warning: For safety while maintaining the machine, please shut off the main input power and wait for 5 minutes, until capacitors voltage already drop to safe voltage 36V!**

Date	Maintenance items
Daily examination	<p>Observe that the knobs and switches in the front and at the back of arc welding machine are flexible and put correctly in place. If any knob has not been put correctly in place, please correct. If you can't correct or fix the knob, please replace immediately;</p> <p>If any switch is not flexible or it can't be put correctly in place, please replace immediately! Please get in touch with maintenance service department if there are no accessories.</p> <p>After turn-on power, watch/listen if the arc-welding machine has shaking, whistle calling or peculiar smell. If there is one of the above problems, find out the reason and clear it. If you can't find out the reason, please contact your local service repair station or distributor/Agent.</p> <p>Observe that the display value of LED is intact. If the display number is not intact, please replace the damaged LED. If it still doesn't work, please maintain or replace the display PCB.</p> <p>Observe that the min./max. Values on LED agree with the set value. If there is any difference and it has affected the normal welding results, please adjust it.</p> <p>Check whether the fan is damaged and whether it is normal to rotate or control. If the fan is damaged, please change immediately. If the fan does not rotate after the machine is overheated, observe if there is something blocking the blade. If it is blocked, please clear the problem. If the fan does not rotate after getting rid of the above problems, you can poke the blade by the rotation direction of fan. If the fan rotates normally, the start capacity should be replaced. If not, change the fan.</p> <p>Observe whether the fast connector is loose or overheated. If the arc-welding machine has the above problems, it should be fastened or changed.</p> <p>Observe whether the current output cable is damaged. If it is damaged, it should be insulated or changed.</p>

Monthly examination	<p>Using the dry compressed air to clear the inside of arc welding machine. Especially for clearing up the dusts on radiator, main voltage transformer, inductors, IGBT modules, fast recover diodes, PCB's, etc.</p> <p>Check the screws and bolts in the machine. If any is loose, please screw it tight. If it is shaved, please replace. If it is rusty, please erase rust on all bolts to ensure it works well.</p>
Quarter-yearly examination	<p>Check whether the actual current accords with the displaying value. If they did not accord, they should be regulated. The actual welding current value can be measured by and adjusted by plier-type ampere meter.</p>
Yearly examination	<p>Measure the insulating impedance among the main circuit, PCB and case, if it below $1M\Omega$, insulation is thought to be damaged and need to change, and need to change or strengthen insulation.</p>

§6.2 Troubleshooting

- Before the welding machines are dispatched from the factory, they have already been tested and calibrated accurately. **It is forbidden for anyone who is not authorized by our company to do any change to the equipment!**
- Maintenance course must be operated carefully. If any wire becomes flexible or is misplaced, it maybe potential danger to user!
- Only professional maintenance staff that is authorized by our company could overhaul the machine!
- **Be sure to shut off the Main Input Power before doing any repair work on the welding machine!**
- If there is any problem and there is no authorized professional maintenance personal on site, please contact local agent or the distributor!

If there are some simple troubles with the welding machine, you can consult the following Chart:

NO.	Troubles		Reasons	Solution
1	Close the breaker, but the power light isn't on		Breaker damaged	Change it
			Fuse damaged	Change it
			Input power damaged	Change it
2	After welding machine is over-heat, the fan doesn't work		Fan damaged	Change it
			The cable is loose	Screw the cable tight
3	Press the gun switch, no output shielded gas	No output gas when test gas	No gas in the gas cylinder	Change it
			Gas hose leaks gas	Change it
			Electromagnetic valve damaged	Change it
	Output gas when test gas	Control switch damaged	Repair the switch	
		Control circuit damaged	Check the PCB	
4	Wire-feed er doesn't work	Wire reel doesn't work	Motor damaged	Check and change it
			Control circuit damaged	Check the PCB
	Wire reel works	The press wheel is loosen or weld wire skids	Press it tightly again	
		The wheel doesn't fit with the diameter of weld wire	Change the wheel	
		Wire reel damaged	Change it	
		Wire feed pipe is jammed	Repair or change it	
		Tip is jammed because of splash	Repair or change it	
5	No striking arc and no output voltage		Output cable is connected incorrectly or loosen	Screw it down or change it
			Control circuit damaged	Check the circuit
6	Welding stops, and alarm light is on		Machine has self-protection	Check over-voltage, over-current, over-temperature, lower-voltage and over-temperature, and solve it
7	Welding current is run away and can be not controlled		The potentiometer damaged	Check or change it
			The control circuit damaged	Check the circuit
8	The crater current can be not adjusted		The PCB damaged	Check it
9	No post-gas		The PCB damaged	Check it

§6.3 List of error code

Error Type	Error code	Description	Lamp status
Thermal relay	E01	Over-heating(1st thermal relay)	Yellow lamp(thermal protection) always on
	E02	Over-heating(2nd thermal relay)	Yellow lamp(thermal protection) always on
	E03	Over-heating(3rd thermal relay)	Yellow lamp(thermal protection) always on
	E04	Over-heating(4th thermal relay)	Yellow lamp(thermal protection) always on
	E09	Over-heating(Program in default)	Yellow lamp(thermal protection) always on
Welding machine	E10	Phase loss	Yellow lamp(thermal protection) always on
	E11	No water	Yellow lamp(lack water) always on
	E12	No gas	Red lamp always on
	E13	Under voltage	Yellow lamp(thermal protection) always on
	E14	Over voltage	Yellow lamp(thermal protection) always on
	E15	Over current	Yellow lamp(thermal protection) always on
	E16	Wire feeder over load	
Switch	E20	Button fault on operating panel when switch on the machine	Yellow lamp(thermal protection) always on
	E21	Other faults on operating panel when switch on the machine	Yellow lamp(thermal protection) always on
	E22	Torch fault when switch on the machine	Yellow lamp(thermal protection) always on
	E23	Torch fault during normal working process	Yellow lamp(thermal protection) always on
Accessory	E30	Cutting torch disconnection	Red lamp blink
	E31	Water cooler disconnection	Yellow lamp(lack water) always on
Communication	E40	Connection problem between wire feeder and power source	
	E41	Communication error	

§6.4 Electrical schematic drawing

