

OPERATORS' MANUAL



I-ARC-145/I-ARC-160/I-ARC-180/I-ARC-200/I-ARC-220 INVERTER Based Welding Machines

IMPORTANT: Read this Owner's Manual Completely before attempting to use this equipment. Save this manual and keep it handy for quick reference. Pay particular attention to the safety instructions we have provided for your protection. Contact your distributor if you do not fully understand this manual.

CONTENT

§1 Safety	1
§1.1 Symbols Explanation.....	1
§1.2 Machine Operating warnings!.....	1
§1.3 EMC device classification	7
§1.4 EMC measure.....	8
§2 Overview	9
§2.1 Features	9
§2.2 Technical Data.....	9
§2.3 Brief Introduction.....	10
§2.4 Duty cycle and Over-heat.....	11
§2.5 Working Principle.....	11
§2.6 Volt-Ampere Characteristic	12
§3 Installation & Operation	13
§3.1 Layout for the front and rear panel.....	13
§3.2 Installation for MMA Welding	14
§3.3 Operation for MMA Welding	15
§3.4 MMA Welding.....	16
§3.5 MMA Welding Fundamentals	18
§3.5.1 Electrode Selection.....	18
§3.5.2 Electrode Size.....	18
§3.5.3 Welding Current (Amperage).....	18
§3.5.4 Arc Length.....	19
§3.5.5 Electrode Angle	19
§3.5.6 Travel Speed.....	19
§3.5.7 Material and Joint Preparation	19
§3.6 MMA welding trouble shooting.....	19
§3.7 Operation environment	21
§3.8 Operation Notices	21
§4 Maintenance & Troubleshooting	22

§4.1 Maintenance.....22
§4.2 Troubleshooting23
§4.3 Electrical schematic drawing.....26

§1 Safety

Welding and cutting equipment can be dangerous to both the operator and people in or near the surrounding working area, if the equipment is not correctly operated. Equipment must only be used under the strict and comprehensive observance of all relevant safety regulations. Read and understand this instruction manual carefully before the installation and operation of this equipment.

§1.1 Symbols Explanation



- The above symbols mean warning!

Notice! Running parts, getting an electric shock or making contacts with thermal parts will cause damage to your body and others. The underline message is as follows:

Welding is quite a safe operation after taking several necessary protection measures!

§1.2 Machine Operating warnings!

- The following symbols and words explanations are for some damages to your body or others, which could happen during the welding operation. While seeing these symbols, please remind yourself and others to be careful.
- Only people who are trained professionally can install, debug, operate, maintain and repair the welding equipment covered with this Operator's Manual!
- During the welding operation, non-concerned people should NOT be around, especially children!
- After shutting off the machine power, please maintain and examine the equipment according to §4 because of the DC voltage existing in the electrolytic capacitors at the output of the power supply!



ELECTRIC SHOCK CAN KILL.

Touching live electrical parts can cause fatal shocks or severe burns. The electrode and work circuit is electrically live whenever the output is on. The input power circuit and internal machine circuits are also live when power is on. In Mig/Mag welding, the wire, drive rollers, wire feed housing, and all metal parts touching the welding wire are electrically live. Incorrectly installed or improperly grounded equipment is dangerous.

- Never touch live electrical parts.
- Wear dry, hole-free gloves and clothes to insulate your body.
- Be sure to install the equipment correctly and ground the work or metal to be welded to a good electrical (earth) ground according to the operation manual.
- The electrode and work (or ground) circuits are electrically “hot” when the machine is ON. Do not touch these “hot” parts with your bare skin or wet clothing. Wear dry, hole-free gloves to insulate hands.
- In semiautomatic or automatic wire welding, the electrode, electrode reel, welding head, nozzle or semiautomatic welding gun are also electrically “hot”.
- Insulate yourself from work and ground using dry insulation. Make certain the insulation is large enough to cover your full area of physical contact with work and ground.
- Be Careful when using the equipment in small places, falling-off and wet circumstance.
- Always be sure the work cable makes a good electrical connection with the metal being welded. The connection should be as close as possible to the area being welded.
- Maintain the electrode holder, work clamp, welding cable and welding machine in good, safe operating condition. Replace damaged insulation.
- Never dip the electrode in water for cooling.
- Never simultaneously touch electrically “hot” parts of electrode holders connected to two welders because voltage between the two can be the total of the open circuit voltage of both welders.
- When working above the floor level, use a safety belt to protect yourself from a fall should you get an electric shock!



FUMES AND GASES CAN BE DANGEROUS.

Smoke and gas generated whilst welding or cutting can be harmful to people's health. Welding produces fumes and gases. Breathing these fumes and gases can be hazardous to your health.

- Do not breathe the smoke and gas generated whilst welding or cutting, keep your head out of the fumes. Use enough ventilation and/or exhaust at the arc to keep fumes and gases away from the breathing zone. When welding with electrodes which require special ventilation such as stainless or hard facing or on lead or cadmium plated steel and other metals or coatings which produce highly toxic fumes, keep exposure as low as possible and below the Threshold Limit Values using local exhaust or mechanical ventilation. In confined spaces or in some circumstances, outdoors, a respirator may be required. Additional precautions are also required when welding on galvanized steel.
- Do not weld in locations near chlorinated hydrocarbon vapors coming from degreasing, cleaning or spraying operations. The heat and rays of the arc can react with solvent vapors to form phosgene, a highly toxic gas, and other irritating products.
- Shielded gases used for arc welding can displace air and cause injury or death. Always use enough ventilation, especially in confined areas, to insure breathing air is safe.
- Read and understand the manufacturer's instructions for this equipment and the consumables to be used, including the material safety data sheet and follow your employer's safety practices.

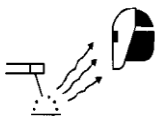

ARC RAYS: Harmful to people's eyes and skin.

Arc rays from the welding process produce intense visible and invisible ultraviolet and infrared rays that can burn eyes and skin.

- Use a shield with the proper filter and cover plates to protect your eyes from sparks and the rays of the arc when welding or observing open arc welding.
- Use suitable clothing made from durable flame-resistant material to protect your skin and that of your coworkers from the arc rays.
- Protect other nearby personnel with suitable, non-flammable screening and /or warn them not to

watch the arc nor expose themselves to the arc rays or to hot spatter or metal.



SELF-PROTECTION

- Keep all equipment safety guards, covers and devices in position and in good repair. Keep hands, hair, clothing and tools away from V-belts, gears, fans and all other moving parts when starting, operating or repairing equipment.
- Do not put your hands near the engine fan. Do not attempt to override the governor or idler by pushing on the throttle control rods while the engine is running.



DO NOT add any fuel near an open-flame welding arc or when the engine is running. Stop the engine and allow it to cool before refueling to prevent spilled fuel from vaporizing on contact with hot engine parts and igniting. Do not spill fuel when filling tank. If fuel is spilled, wipe it up and do not start engine until fumes have been eliminated.



WELDING SPARKS can cause fire or explosion.

Welding on closed containers, such as tanks, drums, or pipes, can cause them to explode. Flying sparks from the welding arc, hot work piece, and hot equipment can cause fires and burns. Accidental contact of electrode to metal objects can cause sparks, explosion, overheating, or fire. Check and be sure the area is safe before doing any welding

- Remove fire hazards material from the welding area. If this is not possible, cover them to prevent the welding sparks from starting a fire. Remember that welding sparks and hot materials from welding can easily go through small cracks and openings to adjacent areas. Avoid welding near hydraulic lines. Have a fire extinguisher readily available.
- Where compressed gases are to be used at the job site, special precautions should be used to prevent hazardous situation.
- When not welding, make certain no part of the electrode circuit is touching the work or ground. Accidental contact can cause overheating and create a fire hazard.

- Do not heat, cut or weld tanks, drums or containers until the proper steps have been taken to insure that such procedures will not cause flammable or toxic vapors from substances inside. They can cause an explosion even though they have been “cleaned”.
- Vent hollow castings or containers before heating, cutting or welding. They may explode.
- Sparks and spatter are thrown from the welding arc. Wear oil free protective garments such as leather gloves, heavy shirt, cuff less trousers, high shoes and a cap over your hair. Wear earplugs when welding out of position or in confined places. Always wear safety glasses with side shields when in a welding area.
- Connect the work cable to the work as close to the welding area as practical. Work cables connected to the building framework or other locations away from the welding area increase the possibility of the welding current passing through lifting chains, crane cables or other alternate circuits. This can create fire hazards or overheat lifting chains or cables until they fail.



Rotating parts may be dangerous.

- Use only compressed gas cylinders containing the correct shielding gas for the process used and properly operating regulators designed for the gas and pressure used. All hoses, fittings, etc. should be suitable for the application and maintained in good condition.
- Always keep cylinders in an upright position securely chained to an undercarriage or fixed support.
- Cylinders should be located:
 - Away from areas where they may be struck or subjected to physical damage.
 - At a safe distance from arc welding or cutting operations and any other source of heat, sparks, or flame.
- Never allow the electrode, electrode holder or any other electrically “hot” parts to touch a gas cylinder.
- Keep your head and face away from the cylinder valve outlet when opening the cylinder valve.
- Valve protection caps should always be in place and hand tight except when the cylinder is in use or connected for use.

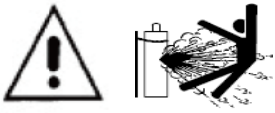

Gas Cylinders.

Shielding gas cylinders contain gas under high pressure. If damaged, a cylinder can explode. Because gas cylinders are normally part of the welding process, be sure to treat them carefully. CYLINDERS can explode if damaged.

- Protect gas cylinders from excessive heat, mechanical shocks, physical damage, slag, open flames sparks, and arcs.
- Insure cylinders are held secure and upright to prevent tipping or falling over.
- Never allow the welding electrode or earth clamp to touch the gas cylinder, do not drape welding cables over the cylinder.
- Never weld on a pressurised gas cylinder, it will explode and kill you.
- Open the cylinder valve slowly and turn your face away from the cylinder outlet valve and gas regulator.



Gas build up.

The build up of gas can causes a toxic environment, deplete the oxygen content in the air resulting in death or injury. Many gases use in welding are invisible and odourless.

- Shut off shielding gas supply when not in use.
- Always ventilate confine spaces or use approved air-supplied respirator.



Electric and Magnetic Fields.

Electric current flowing through any conductor causes localized Electric and Magnetic Fields (EMF). The discussion on the effect of EMF is ongoing in the entire world. Up to now, no material evidences show that EMF may have effects on health. However, the research on the effect of EMF is still ongoing. Before any conclusion, we should minimize exposure to EMF as few as possible.

In order to minimize EMF, we should use the following procedures:

- Route the electrode and work cables together – Secure them with tape when possible.
- All cables should be put away and far from the operator.
- Never coil the power cable around your body.
- Make sure welding machine and power cable to be far away from the operator as far as possible according to the actual circumstance.
- Connect the work cable to the workpiece as close as possible to the area being welded.
- The people with heart-pacemaker should be away from the welding area.



Noise can damage hearing.

Noise from some processes or equipment can damage hearing. You must protect your ears from loud noise to prevent permanent loss of hearing.

- To protect your hearing from loud noise, wear protective ear plugs and/or ear muffs. Protect others in the workplace.
- Noise levels should be measured to be sure the decibels (sound) do not exceed safe levels.



Hot parts.

Items being welded generate and hold high heat and can cause severe burns. Do not touch hot parts with bare hands. Allow a cooling period before working on the welding gun. Use insulated welding gloves and clothing to handle hot parts and prevent burns.

§1.3 EMC device classification



Radiation Class A Device.

- Only can be used in the industrial area
- If it is used in other area, it may cause connection and radiation problems of circuit.

Radiation Class B device.

- It can meet the radiation requirements of residential area and industrial area. It also can be used in residential area which power is supplied by public low voltage circuit.

EMC device can be classified by power nameplate or technical data.

Hi-zone welding machines belong to Class A.

§1.4 EMC measure



In the special situation, The specified area may be affected, the standard of radiation limit value has been complied with (eg: The device, which is easy effected by electromagnetism, is used at the installation location, or there is radio

or TV near the installation location). In this condition, the operator should adopt some appropriate measures to remove interference.

Accoring to the domestic and international standards, the ambient devices' electromagnetism situation and anti-interference ability must be checked:

- Safety device
- Power line, Signal transmission line and Date transmission line
- Date processing equipment and telecommunication equipment
- Inspection and calibration device

The effective measures avoid the problem of EMC:

a) Power source

Even though the power source connection meet rules, we still need to take additional measure to remove the electromagnetic interference. (eg: Use the right power filter.)

b) The welding line

- Try to shorten the length of cable
- Put the cable together
- Be Far away from other cable

c) Equipotential connection

d) Ground connection of work-piece

- When necessary, use appropriate capacitance to connect the ground.

e) Shielding, when necessary

- Shield the ambient devices
- Shield the whole welding machine

§2 Overview

§2.1 Features

- **Extra functions**

"Hot Start", "Arc Force" and "Anti-sticking" built in.

"Hot Start" function for easier arc striking;

"Arc Force" to prevent electrode sticking to the work- piece ; Smoother welding and deeper penetration;

"Anti-sticking" device to prevent overload and ease

the electrode removal from the workpiece.

- **Protections**

Fully protected against over-voltage , under-voltage and over-heat.

- **Weight**

Extremely low weight and versatility.

- **Generator friendly**

Designed to work with diesel generators and to avoid failures due to its voltage spikes.

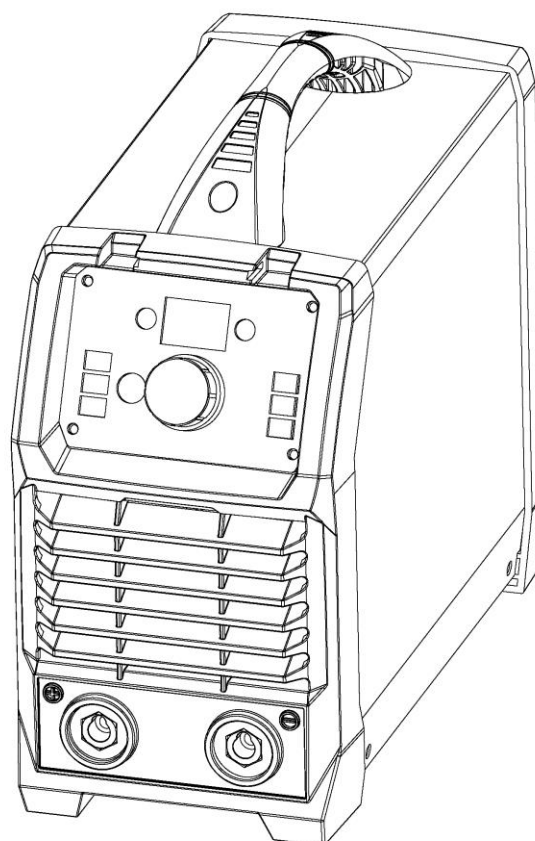

§2.2 Technical Data

Parameters	Models				
	I-ARC-145	I-ARC-160	I-ARC-180	I-ARC-200	I-ARC-220
Power Supply Voltage (V)	1-230V ± 10%	1-230V ± 10%	1-230V ± 10%	1-230V ± 10%	1-230V ± 10%
Frequency(HZ)	50/60	50/60	50/60	50/60	50/60
Rated input current (A)	36	36	39	46	52
Rated input power (KW)	5.0	5.0	5.6	6.5	7.3
Duty cycle (40°C 10 min)	20% 140A	25% 160A	20% 180A	25% 200A	20% 220A
	60% 105A	60% 105A	60% 105A	60% 130A	60% 130A

	100% 80A	100% 80A	100% 80A	100% 100A	100% 100A
Welding Current Range (A)	10-160	10-160	10-180	10-200	10-220
No Load Voltage(V)	70	70	70	70	70
Efficiency(%)	≥80%	≥80%	≥80%	≥80%	≥80%
Power Factor	0.65	0.65	0.65	0.65	0.65
Insulation class	H	H	H	H	H
Protection class	IP23	IP23	IP23	IP23	IP23
Cooling	AF	AF	AF	AF	AF
Net Weight(Kg)	3.2	3.2	3.2	3.5	3.5
Dimensions(mm)	290X140X 265	290X140X2 65	290X140X 265	290X140X2 65	290X140X2 65
Electrode Diameter	φ 1.6~ φ 4.0	φ 1.6~ φ 4.0	φ 1.6~ φ 5.0	φ 1.6~ φ 5.0	φ 1.6~ φ 5.0
Electrode Type	6013,7018 etc.	6013,7018 etc.	6013,7018 etc.	6013,7018 etc.	6013,7018 etc.

Note: The above parameters are subject to change with future machine improvement!

§2.3 Brief Introduction

ARC series of welding machines adopt the latest Pulse Width Modulation (PWM) technology and the Insulated Gate Bipolar Transistor (IGBT) power modules. It uses switching frequencies in the 20KHz-50KHz ranges so as to replace the traditional line-frequency transformer type welding machines. Thus, machines are characterized with portability, small size, lightweight, low energy consumption and noise, etc.

ARC series of welding machines has excellent performance: constant current output makes welding arc more stable; fast dynamic response speed reduces the impact from the arc length fluctuation to the current; accurate stepless current adjustment and pre-setting function. There are also some automatic protection functions for under voltage, over current, over heat, etc. inside the welder, when the problems listed before occurred, the alarm light on the front panel is on and at the same time the output current will be cut off. It can self-protect, prolong the usefull life, greatly improved the reliability and practicality of the welding machine.

ARC series of welding machines can be ignited easily, also with little splash and good weld bead.

ARC series of welding machines is widely used in Petroleum, chemical, mechanical, shipbuilding, architecture, boiler, pressure container, military industry and Maintenance work , etc.

This machine has high duty cycle even in the 40°C, which can keep the continuous operation. The frame is Stability of the machine, which can keep working under high temperature and corrosion environment.

§2.4 Duty cycle and Over-heat

The letter “X” stands for Duty Cycle, which is defined as the portion of the time a welding machine can weld continuously with it’s rated output current within a certain time cycle (10 minutes).

The relation between the duty cycle “X” and the output welding current “I” is shown as the right figure.

If the welding machine is overheating, the IGBT over-heat protection sensing will send a signal to the welding machine control unit to cut the output welding current OFF and light the over-heat pilot lamp on the front panel. In that case, the machine should not be welding for 10-15 minutes to cool down with the fanrunning. When operating the machine again, the welding output current or the duty cycle should be reduced.

§2.5 Working Principle

The working principle of ARC series of welding machines is shown in the following figure. Single-phase 220V line frequency AC is rectified into DC (about 312V), then is converted to medium frequency AC (about 50KHz) by inverter device (IGBT), after reducing voltage by medium transformer (the main transformer) and rectified by medium frequency rectifier (fast recovery diode), and is outputted by inductance filtering. The circuit adopts current feedback control technology to insure current output stability. Meanwhile, the welding current parameters can be adjusted continuously and steplessly to meet with the requirements of welding craft.

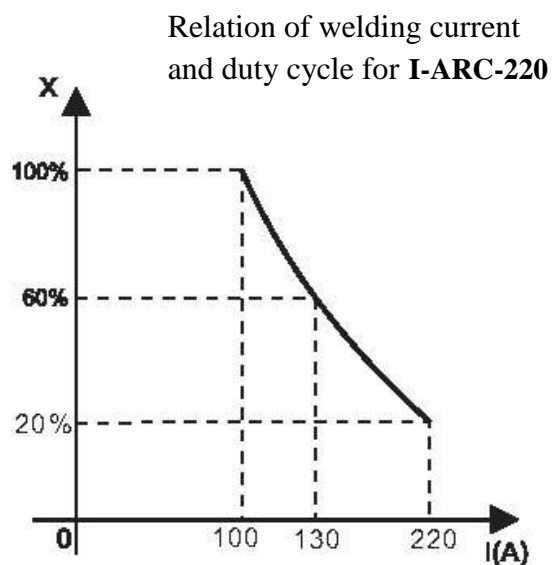

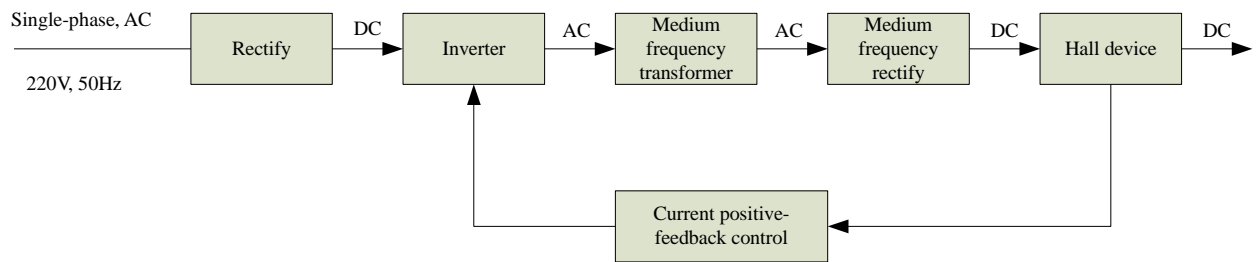

§2.6 Volt-Ampere Characteristic

ARC series of welding machines has excellent volt-ampere characteristic. Referring to the following graph. In MMA welding, the relation between the rated loading voltage U_2 and welding current I_2 is as follows:

When $I_2 \leq 600\text{A}$, $U_2 = 20 + 0.04 I_2$ (V) ; When $I_2 > 600\text{A}$, $U_2 = 44$ (V) .

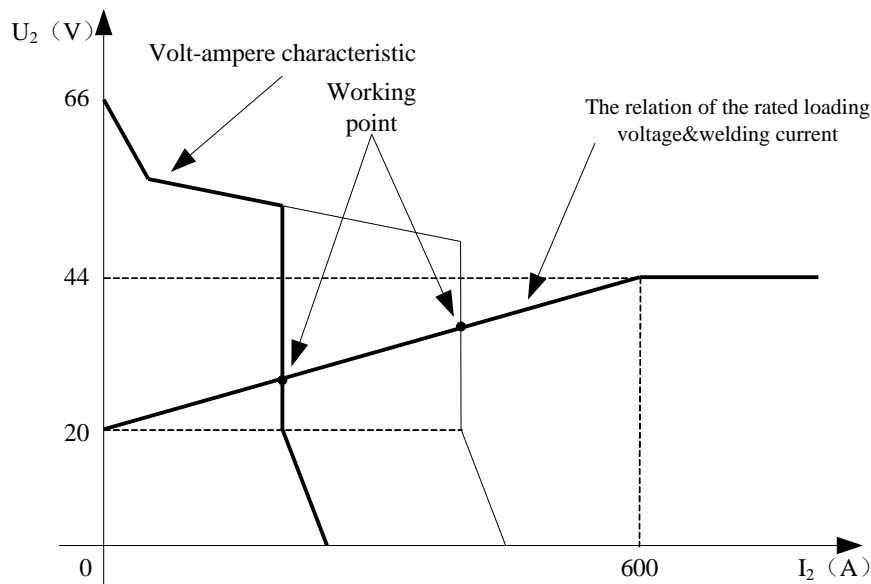

§3 Installation & Operation

§3.1 Layout for the front and rear panel

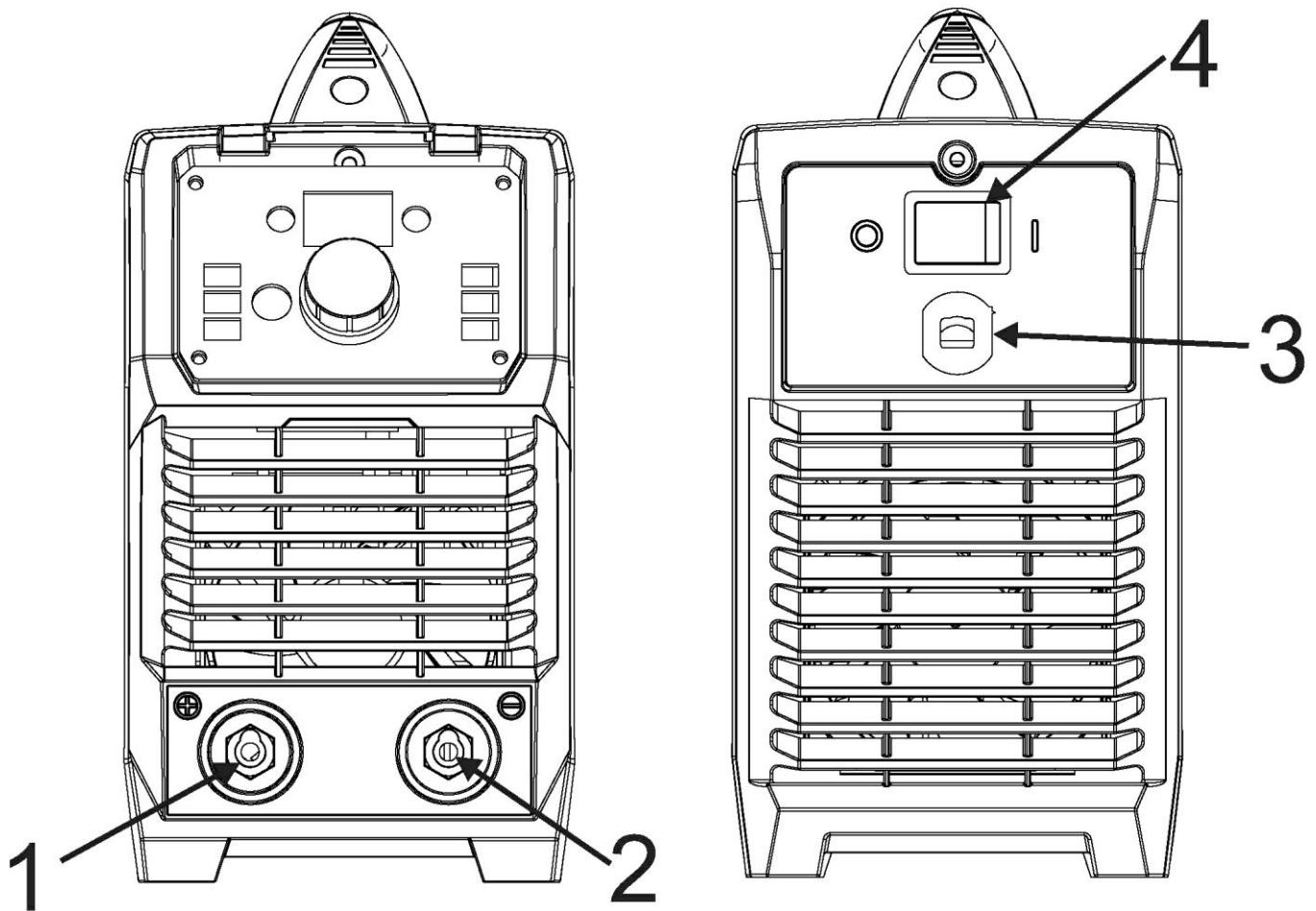

- (1) “+” Output terminal.
- (2) “-” Output terminal.
- (3) Power input.
- (4) Power switch: control power through and break.

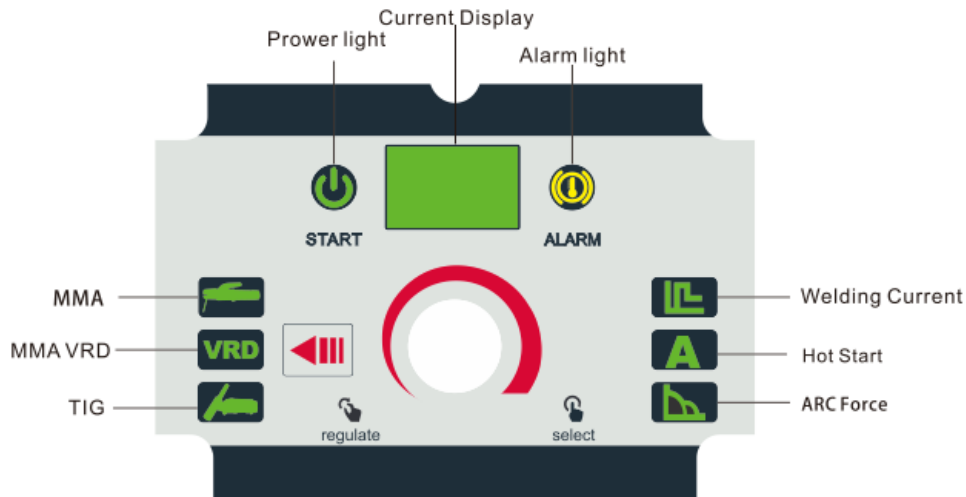

§3.2 Installation for MMA Welding

Connection of Output Cables

Two sockets are available on this welding machine. For MMA welding the electrode holder is shown be connected to the positive socket, while the earth lead (work piece) is connected to the negative socket, this is known as DCEP. However various electrodes require a different polarity for optimum results and careful attention should be paid to the polarity, refer to the electrode manufacturers information for the correct polarity.

DCEP: Electrode connected to “+” output socket.

DCEN: Electrode connected to “-” output socket.

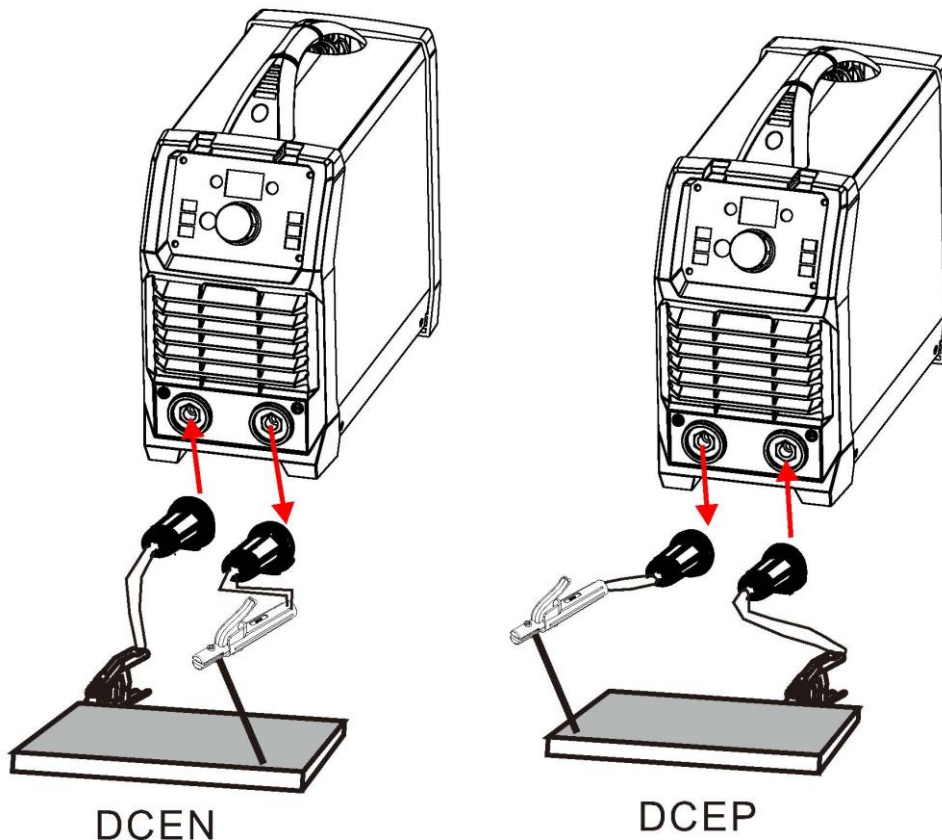

power cable connected to the appropriate position, not to pick the wrong voltage;

- (4) With the corresponding input power supply terminal or socket good contact and prevent oxidation;
- (5) With a multi meter measure the input voltage is within the fluctuation range;
- (6) The power ground is well grounded.

§3.3 Operation for MMA Welding

- (1) According to the above method to install is correct, turn the power switch, so that the power switch is “ON” position, then the power indicator light, the fan comes on, the device work properly.
- (2) Set the welding current relevant to the electrode type and size being used as recommended by the electrode manufacturer.
- (3) Place the electrode into the electrode holder and clamp tight.
- (4) Strike the electrode against the work piece to create and arc and hold the electrode steady to maintain the arc.
- (5) Commence welding. If necessary, readjust the Weld Current control to obtain the welding condition re-quired.

- (6) After completion of welding the Power Source should be left turned ON for 2 to 3 minutes. This allows the fan to run and cool the internal components.

- (7) Switch the ON/OFF Switch (located on the rear panel) to the OFF position.

NOTE:

- Note the polarity of wiring, the general DC welding wire in two ways. Selected according to the technical requirements of welding the appropriate connection, if you choose incorrectly will result in arc instability and spatter large adhesion and other phenomena, such cases can be quickly reversed to joints.
- If the work piece distance from the welding machine, the second line (electrode holder and ground) is longer, so choose the appropriate conductor cross-sectional area should be larger to reduce cable voltage drop.

§3.4 MMA Welding

One of the most common types of arc welding is manual metal arc welding (MMA) or stick welding. An electric current is used to strike an arc between the base material and a consumable electrode rod or ‘stick’. The electrode rod is made of a material that is compatible with the base material being welded and is covered with a flux that gives off gaseous vapours that serve as a shielding gas and providing a layer of slag, both of which protect the weld area from atmospheric contamination. The electrode core itself acts as filler material the residue from the flux that forms slag covering over the weld metal must be chipped away after welding.

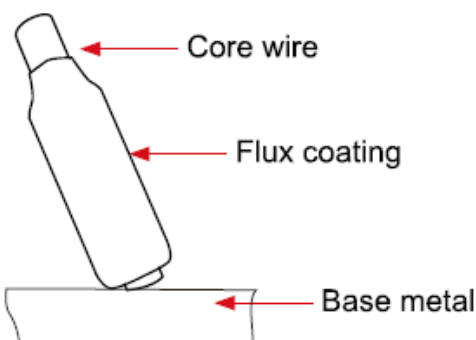
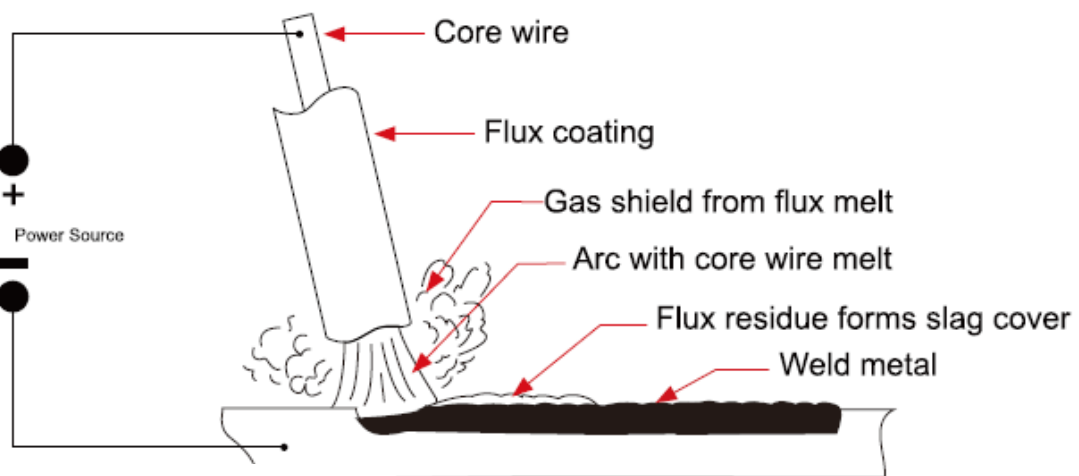

- The arc is initiated by momentarily touching the electrode to

the base metal.

- The heat of the arc melts the surface of the base metal to form a molten pool at the end of the electrode.
- The melted electrode metal is transferred across the arc into the molten pool and becomes the deposited weld metal.
- The deposit is covered and protected by a slag which comes from the electrode coating.

- The arc and the immediate area are enveloped by an atmosphere of protective gas.

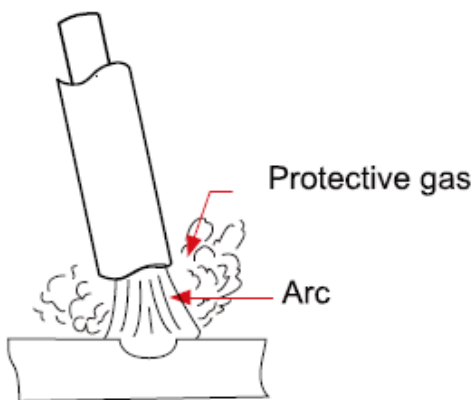

welding pool.

Manual metal arc (stick) electrodes have a solid metal wire core and a flux coating. These electrodes are identified by the wire diameter and by a series of letters and numbers. The letters and numbers identify the metal alloy and the intended use of the electrode.

The **Metal Wire Core** works as conductor of the current that maintains the arc. The core wire melts and is deposited into the

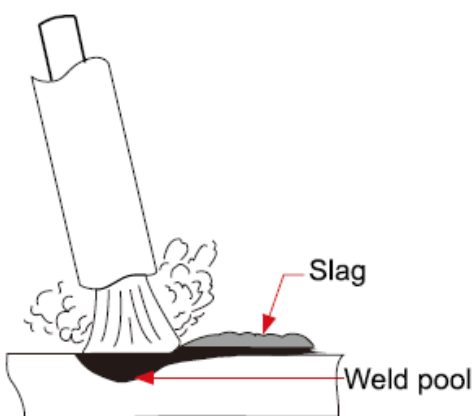

The covering on a shielded metal arc welding electrode is called **Flux**.

The flux on the electrode performs many different functions.

These include:

- producing a protective gas around the weld area
- providing fluxing elements and deoxidizer
- creating a protective slag coating over the weld as it cools
- establishing arc characteristics
- adding alloying elements.

Covered electrodes serve many purposes in addition to filler metal to the molten pool. These additional functions are

provided mainly by the covering on the electrode.

§3.5 MMA Welding Fundamentals

§3.5.1 Electrode Selection

As a general rule, the selection of an electrode is straight forward, in that it is only a matter of selecting an electrode of similar composition to the parent metal. However, for some metals there is a choice of several electrodes, each of which has particular properties to suit specific classes of work. It is recommended to consult your welding supplier for the correct selection of electrode.

§3.5.2 Electrode Size

Average Thickness of Material	Maximum Recommended Electrode Diameter
1.0-2.0 mm	2.5 mm
2.0-5.0 mm	3.2 mm
5.0-8.0 mm	4.0 mm
>8.0 mm	5.0 mm

The size of the electrode generally depends on the thickness of the section being welded, and the thicker the section the larger the electrode required. The table gives the maximum size of electrodes that may be used for various thicknesses of section based on using a general purpose type 6013 electrode.

§3.5.3 Welding Current (Amperage)

Electrode Size ø mm	Current Range (Amps)
2.5 mm	60-95
3.2 mm	100-130
4.0 mm	130-165
5.0 mm	165-260

Correct current selection for a particular job is an important factor in arc welding. With the current set too low, difficulty is experienced in striking and maintaining a stable arc. The electrode tends to stick to the work, penetration is poor and beads with a distinct rounded profile will be deposited. Too high current is accompanied by overheating of the

electrode resulting in undercut and burning through of the base metal and producing excessive spatter. Normal current for a particular job may be considered as the maximum, which can be

used without burning through the work, over-heating the electrode or producing a rough spattered surface. The table shows current ranges generally recommended for a general purpose type 6013 electrode.

§3.5.4 Arc Length

To strike the arc, the electrode should be gently scraped on the work until the arc is established. There is a simple rule for the proper arc length; it should be the shortest arc that gives a good surface to the weld. An arc too long reduces penetration, produces spatter and gives a rough surface finish to the weld. An excessively short arc will cause sticking of the electrode and result in poor quality welds. General rule of thumb for down hand welding is to have an arc length no greater than the diameter of the core wire.

§3.5.5 Electrode Angle

The angle that the electrode makes with the work is important to ensure a smooth, even transfer of metal. When welding in down hand, fillet, horizontal or overhead the angle of the electrode is generally between 5 and 15 degrees towards the direction of travel. When vertical up welding the angle of the electrode should be between 80 and 90 degrees to the work piece.

§3.5.6 Travel Speed

The electrode should be moved along in the direction of the joint being welded at a speed that will give the size of run required. At the same time, the electrode is fed downwards to keep the correct arc length at all times. Excessive travel speeds lead to poor fusion, lack of penetration etc, while too slow a rate of travel will frequently lead to arc instability, slag inclusions and poor mechanical properties.

§3.5.7 Material and Joint Preparation

The material to be welded should be clean and free of any moisture, paint, oil, grease, mill scale, rust or any other material that will hinder the arc and contaminate the weld material. Joint preparation will depend on the method used include sawing, punching, shearing, machining, flame cutting and others. In all cases edges should be clean and free of any contaminants. The type of joint will be determined by the chosen application.

§3.6 MMA welding trouble shooting

The following chart addresses some of the common problems of MMA welding. In all cases of

equipment malfunction, the manufacturer's recommendations should be strictly adhered to and followed.

NO.	Trouble	Possible Reason	Suggested Remedy
1	No arc	Incomplete welding circuit	Check earth lead is connected. Check all cable connections.
		No power supply	Check that the machine is switched on and has a power supply
2	Porosity – small cavities or holes resulting from gas pockets in weld metal	Arc length too long	Shorten the arc length
		Work piece dirty, contaminated or moisture	Remove moisture and materials like paint, grease, oil, and dirt, including mill scale from base metal
		Damp electrodes	Use only dry electrodes
3	Excessive Spatter	Amperage too high	Decrease the amperage or choose a larger electrode
		Arc length too long	Shorten the arc length
4	Weld sits on top, lack of fusion	Insufficient heat input	Increase the amperage or choose a larger electrode
		Work piece dirty, contaminated or moisture	Remove moisture and materials like paint, grease, oil, and dirt, including mill scale from base metal
		Poor welding technique	Use the correct welding technique or seek assistance for the correct technique
5	Lack of penetration	Insufficient heat input	Increase the amperage or choose a larger electrode
		Poor welding technique	Use the correct welding technique or seek assistance for the correct technique
		Poor joint preparation	Check the joint design and fit up, make sure the material is not too thick. Seek assistance for the correct joint design and fit up
6	Excessive penetration - burn through	Excessive heat input	Reduce the amperage or use a smaller electrode
		Incorrect travel speed	Try increasing the weld travel speed
7	Uneven weld appearance	Unsteady hand, wavering hand	Use two hands where possible to steady up, practise your technique
8	Distortion – movement of base metal during	Excessive heat input	Reduce the amperage or use a smaller electrode
		Poor welding technique	Use the correct welding technique or

	welding		seek assistance for the correct technique
		Poor joint preparation and or joint design	Check the joint design and fit up, make sure the material is not too thick. Seek assistance for the correct joint design and fit up
9	Electrode welds with different or unusual arc characteristic	Incorrect polarity	Change the polarity, check the electrode manufacturer for correct polarity

§3.7 Operation environment

- ▲ Height above sea level ≤ 1000 M
- ▲ Operation temperature range $-10 \sim +40$ °C
- ▲ Air relative humidity is below 90 % (20 °C)
- ▲ Preferable site the machine some angles above the floor level, the maximum angle does not exceed 15°.
- ▲ Protect the machine against heavy rain AND against direct sunshine.
- ▲ The content of dust, acid, corrosive gas in the surrounding air or substance cannot exceed normal standard.
- ▲ Take care that there is sufficient ventilation during welding. There must be at least 30cm free distance between the machine and wall.

§3.8 Operation Notices

- ▲ Read Section §1 carefully before starting to use this equipment.
- ▲ Connect the ground wire with the machine directly.
- ▲ Ensure that the input is single-phase: 50/60Hz, 110V $\pm 10\%$.
- ▲ Before operation, none concerned people should not be around the working area and especially children. Do not watch the arc in unprotected eyes.
- ▲ Ensure good ventilation of the machine to improve Duty Cycle.
- ▲ Turn off the engine when the operation finished for energy consumption efficiency.
- ▲ When power switch shuts off protectively because of failure. Don't restart it until problem is resolved. Otherwise, the range of problem will be extended.
- ▲ In case of problems, contact your local dealer if no authorized maintenance staff is available!

§4 Maintenance & Troubleshooting

§4.1 Maintenance

In order to guarantee safe and proper operation of welding machines, they must be maintained regularly. Let customers understand the maintenance procedure of welding machines. Enable customers to carry on simple examination and inspections. Do your best to reduce the fault rate and repair times of welding machines to lengthen service life of arc welding machine. Maintenance items in detail are in the following table.

- **Warning: For safety while maintaining the machine, please shut off the main input power and wait for 5 minutes, until capacitors voltage already drop to safe voltage 36V!**

Date	Maintenance items
Daily examination	<p>Observe that the knobs and switches in the front and at the back of arc welding machine are flexible and put correctly in place. If any knob has not been put correctly in place, please correct. If you can't correct or fix the knob, please replace immediately;</p> <p>If any switch is not flexible or it can't be put correctly in place, please replace immediately! Please get in touch with maintenance service department if there are no accessories.</p> <p>After turn-on power, watch/listen if the arc-welding machine has shaking, whistle calling or peculiar smell. If there is one of the above problems, find out the reason and clear it. If you can't find out the reason, please contact your local service repair station or distributor/Agent.</p> <p>Observe that the display value of LED is intact. If the display number is not intact, please replace the damaged LED. If it still doesn't work, please maintain or replace the display PCB.</p> <p>Observe that the min./max. Values on LED agree with the set value. If there is any difference and it has affected the normal welding results, please adjust it.</p> <p>Check whether the fan is damaged and whether it is normal to rotate or control. If the fan is damaged, please change immediately. If the fan does not rotate after the machine is overheated, observe if there is something blocking the blade. If it is blocked, please clear the problem. If the fan does not rotate after getting rid of the above problems, you can poke the blade by the rotation direction of fan. If the fan rotates normally, the start capacity should be replaced. If not, change the fan.</p> <p>Observe whether the fast connector is loose or overheated. If the arc-welding machine has the above problems, it should be fastened or changed.</p> <p>Observe whether the current output cable is damaged. If it is damaged, it should be insulated or changed.</p>

Monthly examination	Using the dry compressed air to clear the inside of arc welding machine. Especially for clearing up the dusts on radiator, main voltage transformer, inductors, IGBT modules, fast recover diodes, PCB's, etc. Check the screws and bolts in the machine. If any is loose, please screw it tight. If it is shaved, please replace. If it is rusty, please erase rust on all bolts to ensure it works well.
Quarter-yearly examination	Check whether the actual current accords with the displaying value. If they did not accord, they should be regulated. The actual welding current value can be measured by and adjusted by plier-type ampere meter.
Yearly examination	Measure the insulating impedance among the main circuit, PCB and case, if it below $1M\Omega$, insulation is thought to be damaged and need to change, and need to change or strengthen insulation.

§4.2 Troubleshooting

- Before the welding machines are dispatched from the factory, they have already been tested and calibrated accurately. **It is forbidden for anyone who is not authorized by our company to do any change to the equipment!**
- Maintenance course must be operated carefully. If any wire becomes flexible or is misplaced, it maybe potential danger to user!
- Only professional maintenance staff that is authorized by our company could overhaul the machine!
- **Be sure to shut off the Main Input Power before doing any repair work on the welding machine!**
- If there is any problem and there is no authorized professional maintenance personal on site, please contact local agent or the distributor!

If there are some simple troubles with the welding machine, you can consult the following Chart:

S/N	Troubles	Reasons	Solutions
1	Turn on the power source, and fan works, but the power light is not on.	The power light damaged or connection is not good	Test and repair the inside circuit of power light Pr3
		Power PCB failures	Repair or change power PCB Pr2

THANK YOU FOR USING OUR PRODUCTS

2	Turn on the power source, and the power light is on, but fan doesn't work	There is something in the fan	Clear out
		The fan motor damaged	Change fan motor
3	Turn on the power source, and the power light is not on, and fan doesn't work	No input voltage	Check whether there is input voltage
		Overvoltage (Input voltage is too much or not)	Check input voltage
4	No no-load voltage output	There is trouble inside the machine	Check the main circuit, Pr1 and Pr2
5	No current output in the welding	Welding cable is not connected with the two output of the welder.	Connect the welding cable to the welder's output
		Welding cable is broken	Wrap, repair or change the welding cable
		Earth cable is not connected or loosen	Check the earth clamp
6	Not easy to start arc in the welding, or easy to cause sticking	The plug loosen or connect not well	Check and tighten the plug
		Oil or dust covered the workpiece	Check and clear out
7	The arc is not stable in the welding process	The arc force is too small	Increase the arc force
8	The welding current can not be adjusted	Welding current potentiometer in the front panel connection not so good or damaged	Repair or change the potentiometer
9	The penetration of molten pool is not enough(MMA)	The welding current adjusted too low	Increase the welding current
		The arc force adjusted too small	Increase the arc force
10	Arc blow	Airflow disturbance	Use the shelter from airflow
		The electrode eccentricity	Adjust the electrode angle
			Change the electrode
		Magnetic effect	Incline the electrode to the opposite way of the magnetic blow

THANK YOU FOR USING OUR PRODUCTS

				Change the position of earth clamp or add earth cable in the two side of workpiece
				Use the short arc operation
11	The alarm light is on	Over heat protection	Over welding current	Induce the welding current output
			Working time too long	Induce the duty cycle (interval work)
		Over current protection	Unusual current in the main circuit	Test and repair the main circuit and drive PCB

§4.3 Electrical schematic drawing

