

OPERATORS' MANUAL



TIG 325 AC/DC PULSE INVERTER Based Welding Machine

IMPORTANT: Read this Owner's Manual Completely before attempting to use this equipment. Save this manual and keep it handy for quick reference. Pay particular attention to the safety instructions we have provided for your protection. Contact your distributor if you do not fully understand this manual.

CONTENT

§1 Safety..... 1

 §1.1 Symbols Explanation.....1

 §1.2 Machine Operating warnings!.....1

 §1.3 EMC device classification7

 §1.4 EMC measure.....8

 §1.5 Warning label.....9

§2 Overview..... 10

 §2.1 Features10

 §2.2 Technical Data.....11

 §2.3 Brief Introduction.....11

 §2.4 Duty cycle and Over-heat.....14

 §2.5 Working Principle.....14

 §2.6 Volt-Ampere Characteristic.....15

§3 Installation & Operation 16

 §3.1 Layout for the front and rear panel16

 §3.2 Power supply input Connection28

 §3.3 Installation & Operation for MMA Welding.....29

 §3.3.1 Set up installation for MMA Welding 29

 §3.3.2 Operation for MMA Welding 30

 §3.3.3 MMA Welding..... 31

 §3.3.4 MMA Welding Fundamentals 32

 §3.3.5 MMA Welding trouble shooting..... 34

 §3.4 Installation & Operation for TIG Welding36

 §3.4.1 Set up installation for TIG Welding 36

 §3.4.2 Operation for TIG Welding 37

 §3.4.3 Remote current control..... 38

 §3.4.4 Tig Welding Techniques 39

 §3.4.5 Electrodes 40

 §3.4.6 TIG Welding trouble shooting..... 45

 §3.5 Remote control Configuration.....48

 §3.5.1 Wireless remote control Configuration 48

 §3.5.2 Wire foot pedal Configuration..... 49

§3.6 Operation environment	50
§3.7 Operation Notices	50
§4 Maintenance & Troubleshooting	51
§4.1 Maintenance	51
§4.2 Troubleshooting	52
§4.3 List of error code	54
§4.4 Electrical schematic drawing.....	55

§1 Safety

Welding and cutting equipment can be dangerous to both the operator and people in or near the surrounding working area, if the equipment is not correctly operated. Equipment must only be used under the strict and comprehensive observance of all relevant safety regulations. Read and understand this instruction manual carefully before the installation and operation of this equipment.

§1.1 Symbols Explanation



- The above symbols mean warning!

Notice! Running parts, getting an electric shock or making contacts with thermal parts will cause damage to your body and others. The underline message is as follows:

Welding is quite a safe operation after taking several necessary protection measures!

§1.2 Machine Operating warnings!

- The following symbols and words explanations are for some damages to your body or others, which could happen during the welding operation. While seeing these symbols, please remind yourself and others to be careful.
- Only people who are trained professionally can install, debug, operate, maintain and repair the welding equipment covered with this Operator's Manual!
- During the welding operation, non-concerned people should NOT be around, especially children!
- After shutting off the machine power, please maintain and examine the equipment according to §4 because of the DC voltage existing in the electrolytic capacitors at the output of the power supply!



ELECTRIC SHOCK CAN KILL.

Touching live electrical parts can cause fatal shocks or severe burns. The electrode and work circuit is electrically live whenever the output is on. The input power circuit and internal machine circuits are also live when power is on. In Mig/Mag welding, the wire, drive rollers, wire feed housing, and all metal parts touching the welding wire are electrically live. Incorrectly installed or improperly grounded equipment is dangerous.

- Never touch live electrical parts.
- Wear dry, hole-free gloves and clothes to insulate your body.
- Be sure to install the equipment correctly and ground the work or metal to be welded to a good electrical (earth) ground according to the operation manual.
- The electrode and work (or ground) circuits are electrically “hot” when the machine is ON. Do not touch these “hot” parts with your bare skin or wet clothing. Wear dry, hole-free gloves to insulate hands.
- In semiautomatic or automatic wire welding, the electrode, electrode reel, welding head, nozzle or semiautomatic welding gun are also electrically “hot”.
- Insulate yourself from work and ground using dry insulation. Make certain the insulation is large enough to cover your full area of physical contact with work and ground.
- Be Careful when using the equipment in small places, falling-off and wet circumstance.
- Always be sure the work cable makes a good electrical connection with the metal being welded. The connection should be as close as possible to the area being welded.
- Maintain the electrode holder, work clamp, welding cable and welding machine in good, safe operating condition. Replace damaged insulation.
- Never dip the electrode in water for cooling.
- Never simultaneously touch electrically “hot” parts of electrode holders connected to two welders because voltage between the two can be the total of the open circuit voltage of both welders.
- When working above the floor level, use a safety belt to protect yourself from a fall should you get an electric shock!



FUMES AND GASES CAN BE DANGEROUS.

Smoke and gas generated whilst welding or cutting can be harmful to people's health. Welding produces fumes and gases. Breathing these fumes and gases can be hazardous to your health.

- Do not breathe the smoke and gas generated whilst welding or cutting, keep your head out of the fumes. Use enough ventilation and/or exhaust at the arc to keep fumes and gases away from the breathing zone. When welding with electrodes which require special ventilation such as stainless or hard facing or on lead or cadmium plated steel and other metals or coatings which produce highly toxic fumes, keep exposure as low as possible and below the Threshold Limit Values using local exhaust or mechanical ventilation. In confined spaces or in some circumstances, outdoors, a respirator may be required. Additional precautions are also required when welding on galvanized steel.
- Do not weld in locations near chlorinated hydrocarbon vapors coming from degreasing, cleaning or spraying operations. The heat and rays of the arc can react with solvent vapors to form phosgene, a highly toxic gas, and other irritating products.
- Shielded gases used for arc welding can displace air and cause injury or death. Always use enough ventilation, especially in confined areas, to insure breathing air is safe.
- Read and understand the manufacturer's instructions for this equipment and the consumables to be used, including the material safety data sheet and follow your employer's safety practices.

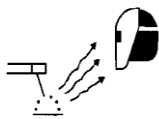

ARC RAYS: Harmful to people's eyes and skin.

Arc rays from the welding process produce intense visible and invisible ultraviolet and infrared rays that can burn eyes and skin.

- Use a shield with the proper filter and cover plates to protect your eyes from sparks and the rays of the arc when welding or observing open arc welding.
- Use suitable clothing made from durable flame-resistant material to protect your skin and that of your coworkers from the arc rays.
- Protect other nearby personnel with suitable, non-flammable screening and /or warn them not to

watch the arc nor expose themselves to the arc rays or to hot spatter or metal.



SELF-PROTECTION

- Keep all equipment safety guards, covers and devices in position and in good repair. Keep hands, hair, clothing and tools away from V-belts, gears, fans and all other moving parts when starting, operating or repairing equipment.
- Do not put your hands near the engine fan. Do not attempt to override the governor or idler by pushing on the throttle control rods while the engine is running.



DO NOT add any fuel near an open-flame welding arc or when the engine is running. Stop the engine and allow it to cool before refueling to prevent spilled fuel from vaporizing on contact with hot engine parts and igniting. Do not spill fuel when filling tank. If fuel is spilled, wipe it up and do not start engine until fumes have been eliminated.



WELDING SPARKS can cause fire or explosion.

Welding on closed containers, such as tanks, drums, or pipes, can cause them to explode. Flying sparks from the welding arc, hot work piece, and hot equipment can cause fires and burns. Accidental contact of electrode to metal objects can cause sparks, explosion, overheating, or fire. Check and be sure the area is safe before doing any welding

- Remove fire hazards material from the welding area. If this is not possible, cover them to prevent the welding sparks from starting a fire. Remember that welding sparks and hot materials from welding can easily go through small cracks and openings to adjacent areas. Avoid welding near hydraulic lines. Have a fire extinguisher readily available.
- Where compressed gases are to be used at the job site, special precautions should be used to prevent hazardous situation.
- When not welding, make certain no part of the electrode circuit is touching the work or ground. Accidental contact can cause overheating and create a fire hazard.
- Do not heat, cut or weld tanks, drums or containers until the proper steps have been taken to

insure that such procedures will not cause flammable or toxic vapors from substances inside. They can cause an explosion even though they have been “cleaned”.

- Vent hollow castings or containers before heating, cutting or welding. They may explode.
- Sparks and spatter are thrown from the welding arc. Wear oil free protective garments such as leather gloves, heavy shirt, cuff less trousers, high shoes and a cap over your hair. Wear earplugs when welding out of position or in confined places. Always wear safety glasses with side shields when in a welding area.
- Connect the work cable to the work as close to the welding area as practical. Work cables connected to the building framework or other locations away from the welding area increase the possibility of the welding current passing through lifting chains, crane cables or other alternate circuits. This can create fire hazards or overheat lifting chains or cables until they fail.



Rotating parts may be dangerous.

- Use only compressed gas cylinders containing the correct shielding gas for the process used and properly operating regulators designed for the gas and pressure used. All hoses, fittings, etc. should be suitable for the application and maintained in good condition.
- Always keep cylinders in an upright position securely chained to an undercarriage or fixed support.
- Cylinders should be located:
 - Away from areas where they may be struck or subjected to physical damage.
 - At a safe distance from arc welding or cutting operations and any other source of heat, sparks, or flame.
- Never allow the electrode, electrode holder or any other electrically “hot” parts to touch a gas cylinder.
- Keep your head and face away from the cylinder valve outlet when opening the cylinder valve.
- Valve protection caps should always be in place and hand tight except when the cylinder is in use or connected for use.

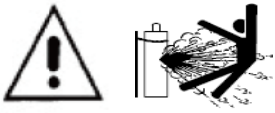

Gas Cylinders.

Shielding gas cylinders contain gas under high pressure. If damaged, a cylinder can explode. Because gas cylinders are normally part of the welding process, be sure to treat them carefully. CYLINDERS can explode if damaged.

- Protect gas cylinders from excessive heat, mechanical shocks, physical damage, slag, open flames sparks, and arcs.
- Insure cylinders are held secure and upright to prevent tipping or falling over.
- Never allow the welding electrode or earth clamp to touch the gas cylinder, do not drape welding cables over the cylinder.
- Never weld on a pressurised gas cylinder, it will explode and kill you.
- Open the cylinder valve slowly and turn your face away from the cylinder outlet valve and gas regulator.



Gas build up.

The build up of gas can causes a toxic environment, deplete the oxygen content in the air resulting in death or injury. Many gases use in welding are invisible and odourless.

- Shut off shielding gas supply when not in use.
- Always ventilate confine spaces or use approved air-supplied respirator.



Electric and Magnetic Fields.

Electric current flowing through any conductor causes localized Electric and Magnetic Fields (EMF). The discussion on the effect of EMF is ongoing in the entire world. Up to now, no material evidences show that EMF may have effects on health. However, the research on the effect of EMF is still ongoing. Before any conclusion, we should minimize exposure to EMF as few as possible.

In order to minimize EMF, we should use the following procedures:

- Route the electrode and work cables together – Secure them with tape when possible.
- All cables should be put away and far from the operator.
- Never coil the power cable around your body.
- Make sure welding machine and power cable to be far away from the operator as far as possible according to the actual circumstance.
- Connect the work cable to the workpiece as close as possible to the area being welded.
- The people with heart-pacemaker should be away from the welding area.



Noise can damage hearing.

Noise from some processes or equipment can damage hearing. You must protect your ears from loud noise to prevent permanent loss of hearing.

- To protect your hearing from loud noise, wear protective ear plugs and/or ear muffs. Protect others in the workplace.
- Noise levels should be measured to be sure the decibels (sound) do not exceed safe levels.



Hot parts.

Items being welded generate and hold high heat and can cause severe burns. Do not touch hot parts with bare hands. Allow a cooling period before working on the welding gun. Use insulated welding gloves and clothing to handle hot parts and prevent burns.

§1.3 EMC device classification



Radiation Class A Device.

- Only can be used in the industrial area
- If it is used in other area, it may cause connection and radiation problems of circuit.

Radiation Class B device.

- It can meet the radiation requirements of residential area and industrial area. It also can be used in residential area which power is supplied by public low voltage circuit.

EMC device can be classified by power nameplate or technical data.

hanker welding machines belong to Class A.

§1.4 EMC measure



In the special situation, The specified area may be affected, the standard of radiation limit value has been complied with (eg: The device, which is easy effected by electromagnetism, is used at the installation location, or there is radio

or TV near the installation location). In this condition, the operator should adopt some appropriate measures to remove interference.

Accoring to the domestic and international standards, the ambient devices' electromagnetism situation and anti-interference ability must be checked:

- Safety device
- Power line, Signal transmission line and Date transmission line
- Date processing equipment and telecommunication equipment
- Inspection and calibration device

The effective measures avoid the problem of EMC:

a) Power source

Even though the power source connection meet rules, we still need to take additional measure to remove the electromagnetic interference. (eg: Use the right power filter.)

b) The welding line

- Try to shorten the length of cable
- Put the cable together
- Be Far away from other cable

c) Equipotential connection

d) Ground connection of work-piece

- When necessary, use appropriate capacitance to connect the ground.

e) Shielding, when necessary

- Shield the ambient devices
- Shield the whole welding machine

§1.5 Warning label

The device with a warning label. **Do not remove, destroy or cover this label.** These warnings are intended to avoid incorrect device operations that could result in serious personal injury or property damage.

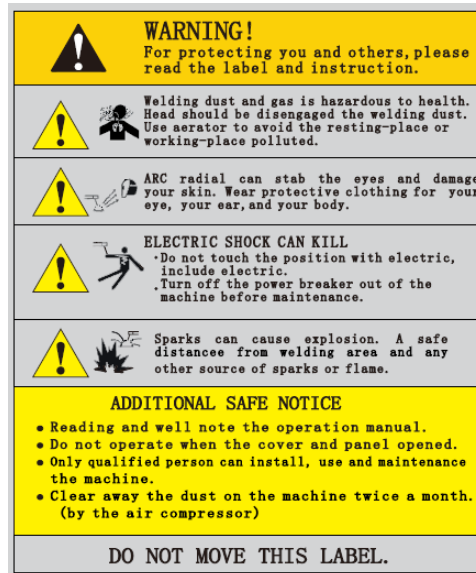

§2 Overview

§2.1 Features

- IGBT module inverter technology for smooth & stable output, increased reliability and high duty cycle.
- Phase loss protection for automatic shut down if power supply phase loss occurs, to prevent damage.
- Integrated heavy duty industrial trolley and water cooler (optional).
- Lift TIG and HF start modes for versatility when welding around sensitive electronic equipment
- Adjustable arc force, hot start & anti stick control for greater control and ease of use when MMA welding.
- Electronic HF TIG arc ignition system for contamination free and easy arc starting with low EMF interference.
- 2T/4T trigger control.
- AC waveforms include square wave, sine wave, triangular wave.
- AC balance control monitors the oxide and helps better cleaning during aluminum welding
- Dual digital display meters for accurate pre-setting and feedback of welding parameters & output.
- Up/ Down Button Remote Control torch and Roller wheel amps control on torch. (optional)
- Wireless Remote Control and Wire / Wireless Foot Pedal. (optional)

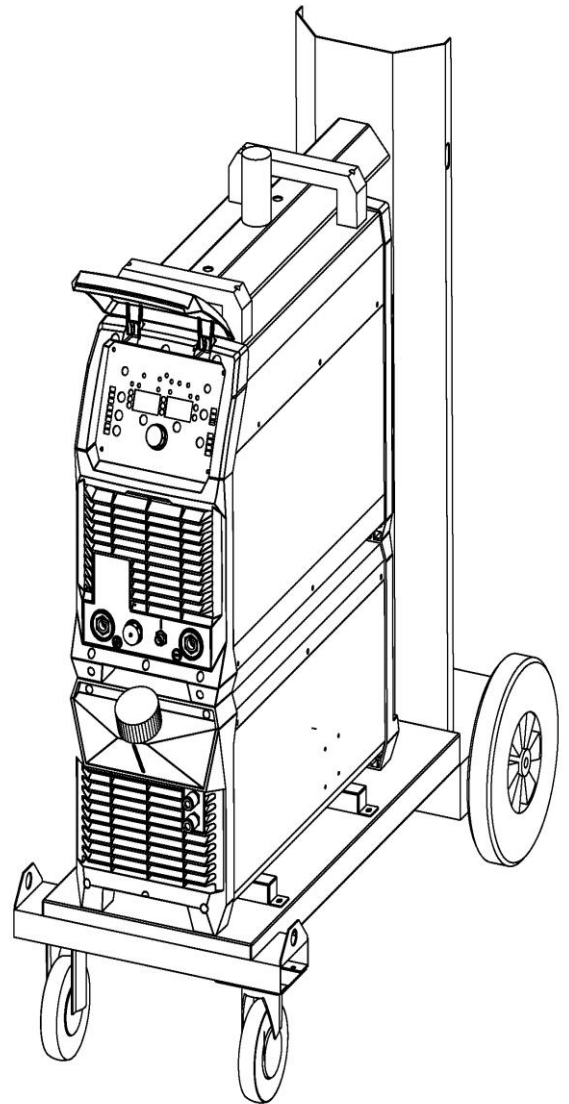

§2.2 Technical Data

Models	TIG 325 AC/DC PULSE
Power Supply Voltage (V)	3~380V/400V/440V ± 10%
Frequency(HZ)	50/60
Rated input current (A)	25 AC MMA 27.5 DC MMA 19 AC TIG 21 DC TIG
Rated input power (KW)	12 AC MMA 13 DC MMA 9 AC TIG 9.5 DC TIG
No Load Voltage(V)	61
Duty cycle (40°C 10 min)	60% 320A
	100% 250A
Welding Current Range (A)	10-320
Up slope/Down slope (S)	0-10.0
Pre/Post Flow (S)	0.1-2.0/0-10.0
Pulse frequency (HZ)	0.5-999
Pulse width range (%)	5-95
AC frequency (HZ)	50~250
Clearance effect (%) AC TIG	-5~+5
Efficiency(%)	≥85%
Insulation class	H
Protection class	IP23
Cooling	AF
Net Weight(Kg)	25.5
Dimensions(mm)	655X255X650

Note: The above parameters are subject to change with future machine improvement!

§2.3 Brief Introduction

TIG series of welding machines adopt the latest Pulse Width Modulation (PWM) technology and the Insulated Gate Bipolar Transistor (IGBT) power modules. It uses switching frequencies in the 20KHz-50KHz ranges so as to replace the traditional line-frequency transformer type welding

machines. Thus, machines are characterized with portability, small size, lightweight, low energy consumption and noise, etc.

The parameters of the machine on the front panel all can be adjusted continuously and steplessly, such as start current, crater arc current, welding current, base current, duty ratio, upslope time, downslope time, pre-gas, post-gas, pulse frequency, AC frequency, balance, hot start, arc force and arc length etc. When welding, it takes high frequency and high voltage for arc igniting to ensure the success ratio of igniting arc.

TIG AC/DC PULSE Characteristics:

- **MCU control system, responds immediately to any changes.**
- **High frequency and high voltage for arc igniting to ensure the success ratio of igniting arc, the reverse polarity ignition ensures good ignition behavior in TIG-AC welding.**
- **Avoid AC arc-break with special means, even if arc-break occurs the HF will keep the arc stable.**
- **Pedal control the welding current.**
- **TIG/DC operation, If the tungsten electrode touches the workpiece when welding, the current will drop to short-circuit current to protect tungsten.**
- **Intelligent protection: over-voltage, over-current, over-heat, when the problems listed before occurred, the alarm lamp on the front panel will be on and the output current will be cut off. It can self-protect and prolong the using life.**
- **Double purposes: AC inverter TIG/MMA and DC inverter TIG/MMA, Excellent performance on Al-alloy、 carbon steel、 stainless steel、 titanium.**

According to choosing the front panel functions, the following six welding ways can be realized.

- DC MMA
- DC TIG
- DC Pulse TIG
- AC MMA
- AC TIG
- AC Pulse TIG

1. For DC MMA, polarity connection can be chosen according to different electrodes, please refer to §3.3.1;
2. For AC MMA, magnetic flow caused by invariable DC polarity can be avoided;
3. For DC TIG, DCEP is used normally (workpiece connected to positive polarity, while torch connected to negative polarity). This connection has many characters, such as stable welding arc, low tungsten pole loss, more welding current, narrow and deep weld;
4. For AC TIG (rectangle wave), arc is more stable than Sine AC TIG. At the same time, you can not only obtain the max penetration and the min tungsten pole loss, but also obtain better clearance effect.
5. DC Pulsed TIG has the following characters: 1) Pulse heating. Metal in Molten pool has short time on high temperature status and freezes quickly, which can reduce the possibility to produce hot crack of the materials with thermal sensitivity. 2) The workpiece gets little heat. Arc energy is focused. Be suitable for thin sheet and super thin sheet welding. 3) Exactly control heat input and the size of the molten pool. The depth of penetration is even. Be suitable for welding by one side and forming by two sides and all position welding for pipe. 4) High frequency arc can make metal for microlite fabric, eliminate blowhole and improve the mechanical performance of the joint. 5) High frequency arc is suitable for high welding speed to improve the productivity.

TIG series of welding machines is suitable for all positions welding for various plates made of stainless steel, carbon steel, alloyed steel, titanium, magnesium, copper, etc, which is also applied to pipe installment, mould mend, petrochemical, architecture decoration, car repair, bicycle, handicraft and common manufacture.

MMA——Manual Metal Arc welding;

PWM——Pulse-Width Modulation;

IGBT——Insulation Gate Bipolar Transistor;

TIG——Tungsten Inert Gas welding.

§2.4 Duty cycle and Over-heat

The letter “X” stands for Duty Cycle, which is defined as the portion of the time a welding machine can weld continuously with its rated output current within a certain time cycle (10 minutes).

The relation between the duty cycle “X” and the output welding current “I” is shown as the right figure.

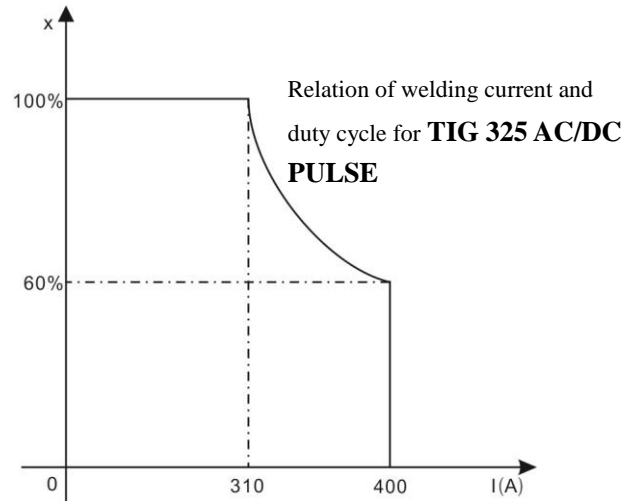

If the welding machine is overheating, the IGBT over-heat protection sensing will send a signal to the welding machine control unit to cut the output welding current OFF and light the over-heat pilot lamp on the front panel. In that case, the machine should not be welding for 10-15 minutes to cool down with the fanrunning. When operating the machine again, the welding output current or the duty cycle should be reduced.

§2.5 Working Principle

The working principle of TIG series of welding machines is shown as the following figure. Three-phase 380V work frequency AC is rectified into DC, then is converted to medium frequency AC by inverter device (IGBT module), after reducing voltage by medium transformer (the main transformer) and rectifying by medium frequency rectifier (fast recovery diodes), then is outputted DC or AC by selecting IGBT module. The circuit adopts current feedback control technology to insure current output stably. Meanwhile, the welding current parameter can be adjusted continuously and steplessly to meet with the requirements of welding craft.

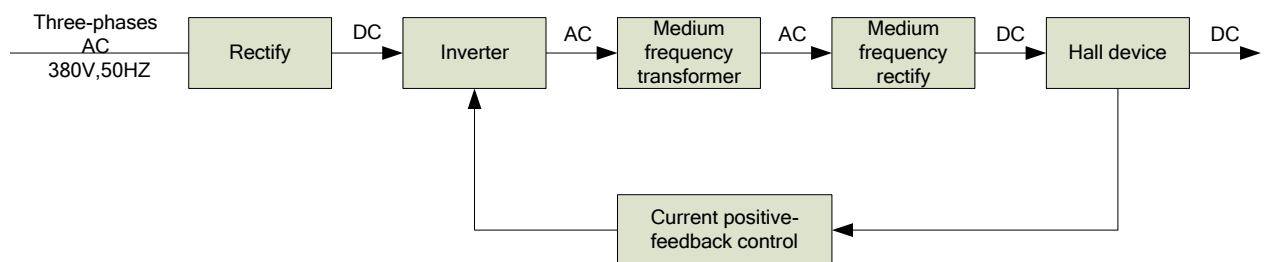

§2.6 Volt-Ampere Characteristic

TIG series of welding machines has excellent volt-ampere characteristic. Referring to the following graph. In TIG welding, the relation between the rated loading voltage U_2 and welding current I_2 is as follows:

When $I_2 \leq 600\text{A}$, $U_2 = 10 + 0.04 I_2$ (V); When $I_2 > 600\text{A}$, $U_2 = 34$ (V) .

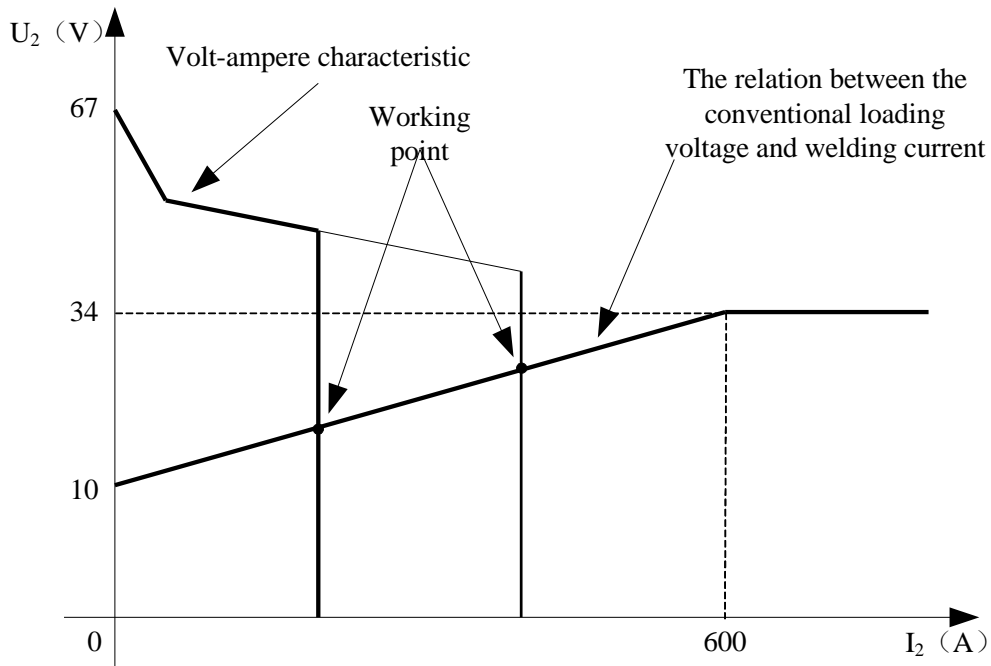

§3 Installation & Operation

§3.1 Layout for the front and rear panel

- (1) “-” Output terminal.
- (2) TIG torch gas connector.
- (3) TIG torch remote connection socket. *
- (4) “+” Output terminal.
- (5) Inlet gas connector.
- (6) Water cooler remote connection socket.
- (7) Power switch.
- (8) Input power cable

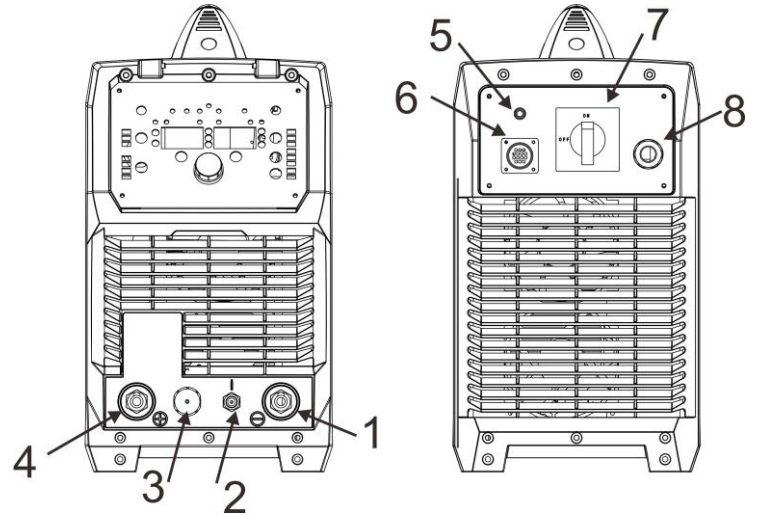

Control Panel

- (9) LH multifunction display.*
- (10) RH multifunction display.*
- (11) Power indicator .
- (12) Water cooling system error indicator.*
- (13) Alarm indicator. *
- (14) Water /air cooling selection button.*
- (15) Air cooling mode indicator
- (16) Water cooling mode indicator
- (17) 2T trigger mode indicator. *
- (18) 4T trigger mode indicator. *
- (19) MMA hot start setting Indicator. *
- (20) MMA welding current setting Indicator.
- (21) MMA arc force setting Indicator. *
- (22) 2T/4Ttrigger mode selector button
- (23) TIG parameter setting indicator. *
- (24) Parameter select/adjust Knob. *
- (25) Welding current mode selection button
- (26) DC wave output indicator. *

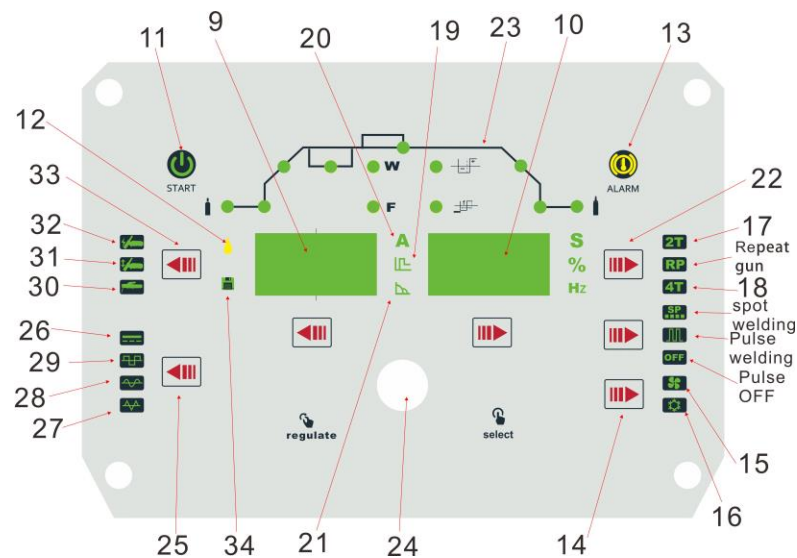

- (27) AC triangle wave output indicator. *
- (28) AC sine wave output indicator. *
- (29) AC advanced square wave output indicator. *
- (30) MMA mode indicator .
- (31) Lift TIG mode indicator. *
- (32) Hf TIG mode indicator. *
- (33) Welding mode selection button
- (34) JOB indicator. *

Water cooler

- (35) Water inlet
- (36) Water supply connector (blue)
- (37) Water return connector (red)
- (38) The water cooling control connector
- (39) Water supply connector (blue)
- (40) Water return connector (red)

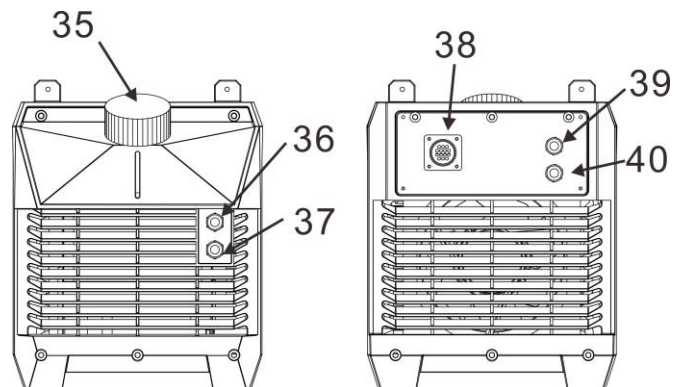

*Denotes more detailed explanation of function to follow.

Further Controls Explained

1) LH Digital Multifunction Display (9)

Before welding this displays the setting selected or being adjusted using the control knob (24). During welding it displays welding current. The parameter setting displayed is indicated by the LEDs beside the display; Current (A), Saved Setting (JOB), Time (S), Percentage (%) and Frequency (Hz). If left inactive for several seconds, display will revert back to main welding current setting.

2) RH Digital Multifunction Display (10)

Before welding this displays secondary functions and error codes. During welding it displays welding voltage.

3) Water Cooling System Error Indicator (12)

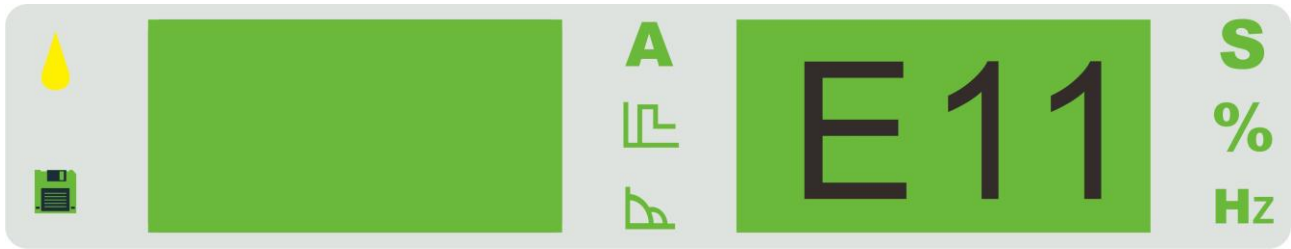

When using the integrated water cooler, the system is equipped with a pressure sensor. If the coolant pressure is insufficient, this indicator will light and the welding output will not be able to be active, in order to protect the torch and cooling system.

4) Alarm Indicator (13)



Lights when over voltage, over current, input phase loss or electrical overheating (due to exceeding duty cycle) is detected and protection is activated. When protection is activated, welding output will be disabled until the safety system senses the overload has reduced sufficiently and indicator lamp goes out. May also trigger if machine experiences an internal power circuit failure.

5) Water/Air Cooling Selection Button (14)

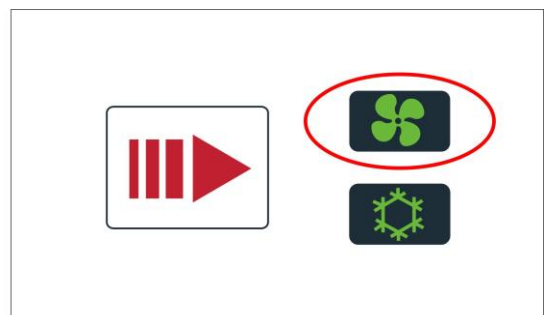
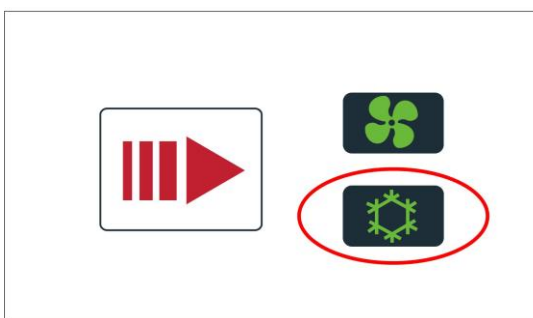

When using the integrated water cooling system with a water cooled torch, select the ‘water’ option (16) by pressing the button (14). This will activate the water cooler power and the water cooling protection system. If using air cooled torch, select ‘Air’ option (15) by pressing the button (14).

Note the welding machine comes standard with a water cooled torch system. Operating a water

cooled torch without water cooling will quickly cause serious damage to the torch. Damage to torch or components due to lack of water is not covered under machine warranty.

6) Multifunction Smart Control Knob (24)

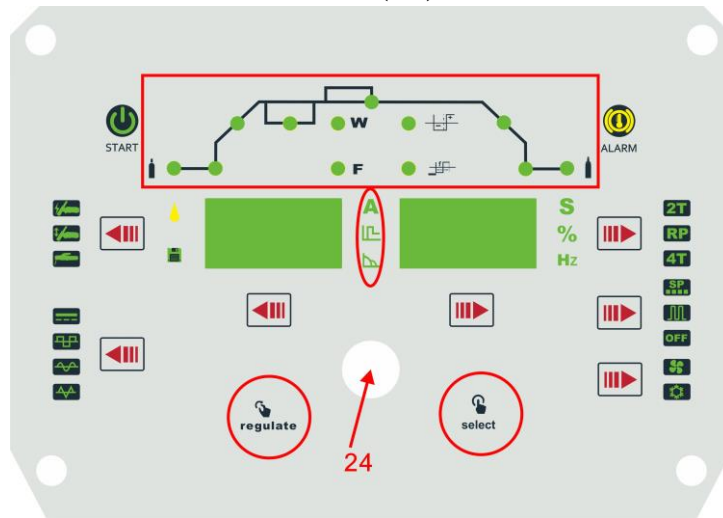

Press knob to navigate through the control panel parameters not controlled by specific selector buttons. Parameter/setting selected will be indicated by the LED on the control panel and the value shown on the LH display(9). Adjust the parameter by turning the knob. Access the job/program store/ recall function by pressing and holding the knob.

7) MMA settings

In MMA mode, switch between welding parameter settings (welding current, hot start and arc force) by pressing the knob (24), parameter/setting selected will be indicated by the LED on the control panel and the value shown on the LH display (9). Adjust the parameter by turning the knob. If left inactive for several seconds, display will revert back to main welding current setting.

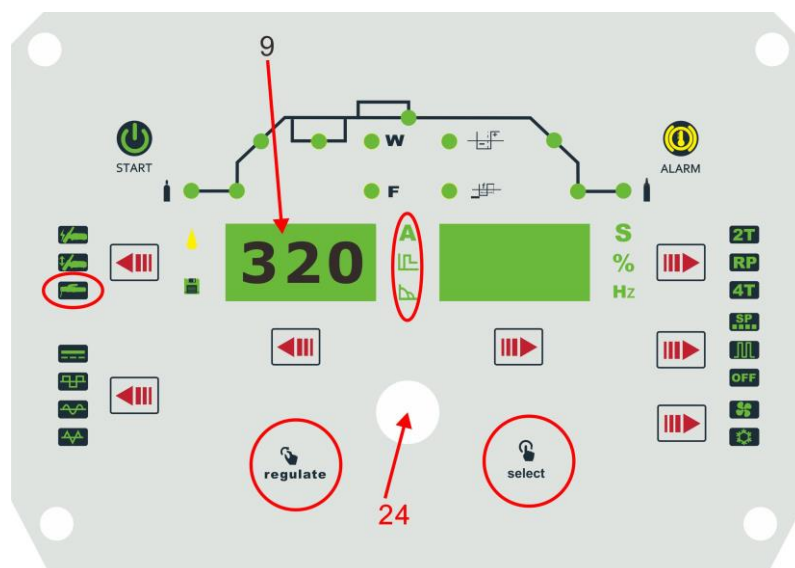

a. Hot start (19)

Hot start provides extra power when the weld starts to counteract the high resistance of the electrode and workpiece as the arc is started. setting range (0-10).

b. Arc force (21)

An MMA welding power source is designed to produce constant output current (CC). This means with different types of electrode and arc length; the welding voltage varies to keep the current constant. This can cause instability in some welding conditions as MMA welding electrodes will have a minimum voltage they can operate with and still have a stable arc.

Arc Force control boosts the welding power if it senses the welding voltage is getting too low. The higher the arc force adjustment, the higher the minimum voltage that the power source will allow. This effect will also cause the welding current to increase. 0 is Arc Force off, 10 is maximum Arc Force. This is practically useful for electrode types that have a higher operating voltage requirement or joint types that require a short arc length such as out of position welds.

8) TIG settings

a. TIG 2T/4T Trigger Control

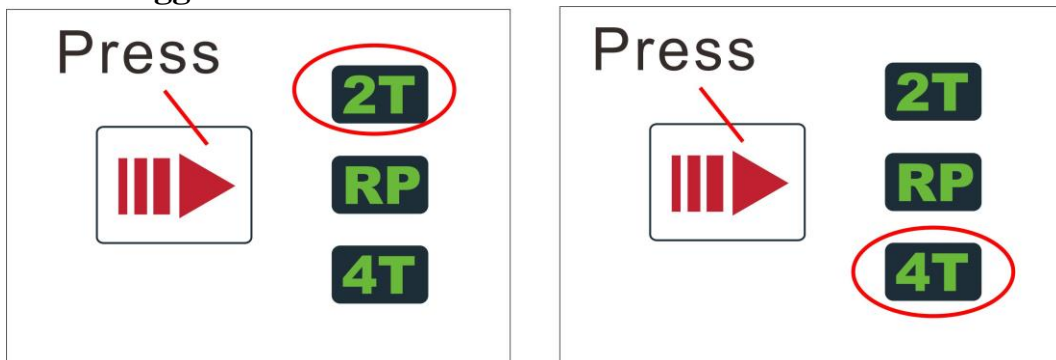

● **2T Mode (17)**

The trigger is pulled and held on to activate the welding circuit, when the trigger is released, the welding circuit stops.

This function without the adjustment of start current and crater current is suitable for the Re-tack welding, transient welding, thin plate welding and so on.

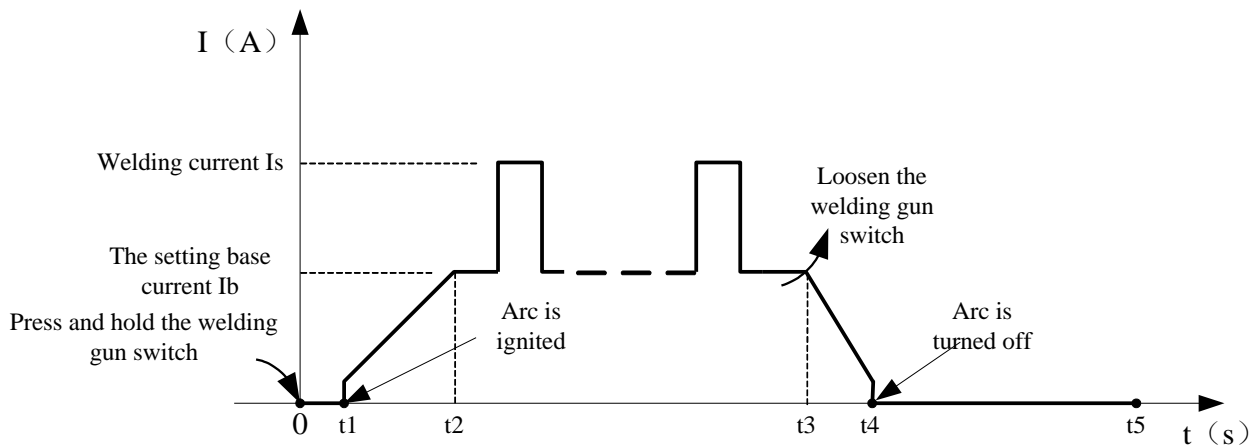

Introduction:

- (1) 0: Press the gun switch and hold it. Electromagnetic gas valve is turned on. The shielding gas starts to flow.
- (2) 0~t1: Pre-gas time (0.1~2.0s)
- (3) t1~t2: Arc is ignited and the output current rises to the setting welding current (I_w or I_b) from the min welding current.
- (4) t2~t3: During the whole welding process, the gun switch is pressed and held without releasing.

Note: Select the pulsed output, the base current and welding current will be outputted alternately; otherwise, output the setting value of welding current;

- (5) t3: Release the gun switch, the welding current will drop in accordance with the selected down-slope time.
- (6) t3~t4: The current drops to the minimum welding current from the setting current (I_w or I_b), and then arc is turned off.
- (7) t4~t5: Post-gas time, after the arc is turned off. You can adjust it (0.0~10s) through turning the knob on the front panel.
- (8) t5: electromagnetic gas valve turned off, the shield gas stops to flow, and welding is finished.

● **4T Mode (18)**

This is known as 'latching' mode. The trigger is pulled once and released to activate the welding circuit, pulled and released again to stops the welding circuit. This function is useful to longer welds as the trigger is not required to be held on continuously. TIG series of

welding machines also has more current control options that can be used in 4T mode.

The start current and crater current can be pre-set. This function can compensate the possible crater that appears at the beginning and end of the welding. Thus, 4T is suitable for the welding of medium thickness plates.

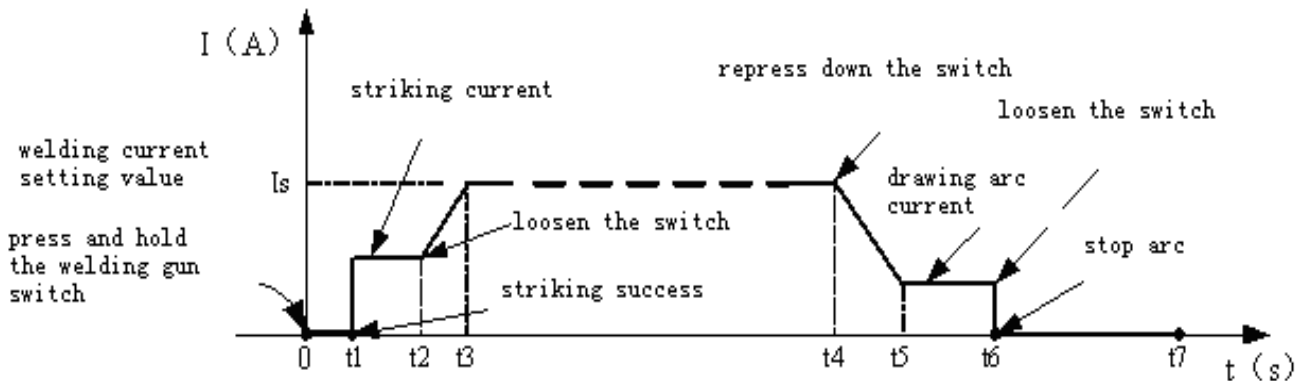

Introduction :

- (1) 0: Press and hold the gun switch, Electromagnetic gas valve is turned on. The shielding gas starts to flow;
- (2) 0~t1: Pre-gas time (0.1~2.0S);
- (3) t1~t2: Arc is ignited at t1 and then output the setting value of start current;
- (4) t2: Loosen the gun switch, the output current slopes up from the start current;
- (5) t2~t3: The output current rises to the setting value (I_w or I_b), the upslope time can be adjusted;
- (6) t3~t4: Welding process. During this period, the gun switch is loosen;

Note: Select the pulsed output, the base current and welding current will be outputted alternately; otherwise, output the setting value of welding current;

- (7) t4: Press the torch switch again, the welding current will drop in accordance with the selected down-slope time.
- (8) t4~t5: The output current slopes down to the crater current. The downslope time can be adjusted;
- (9) t5~t6: The crater current time;
- (10) t6: Loosen the gun switch, stop arc and keep on argon flowing;
- (11) t6~t7: Post-gas time can be set by the post-gas time adjustment knob on the front panel (0.0~10S) ;

(12) t7: Electromagnetic valve is closed and stop argon flowing. Welding is finished.

b. TIG Parameter Setting (23)

In TIG mode, switch between welding parameter settings (pre gas, start current, up slope.....) by pressing the knob (24), parameter/setting selected will be indicated by the LED on the control panel and the value shown on the LH display (9). Adjust the parameter by turning the knob. If left inactive for several seconds, display will revert back to main welding current setting. Switch between pulse and no pulse by turning the knob.

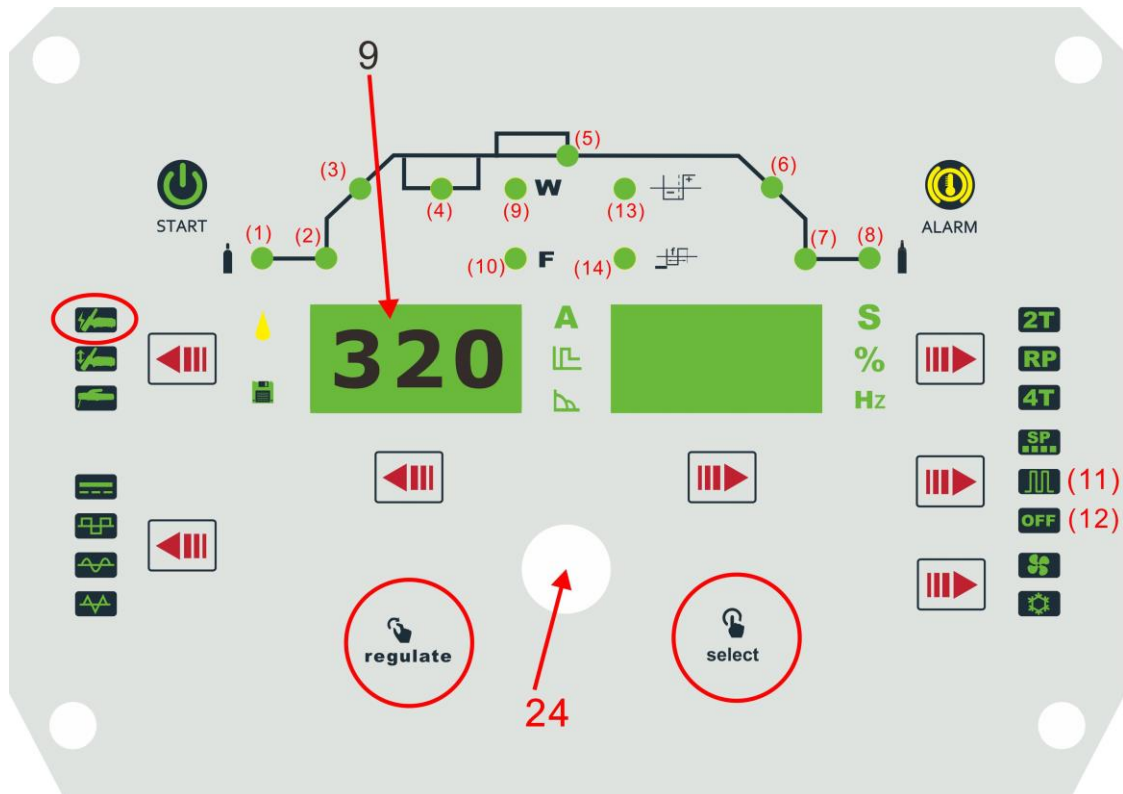

● **Pre gas flow setting indicator (1)**

Pre-flow controls the period shielding gas will flow for when the torch is triggered before the arc starts. This purges the work area of atmospheric gas which could contaminate the weld before the weld starts. Unit(S) and setting range (0.1-2.0S).

● **Start current setting indicator (2)**

Available in 4T trigger mode, sets a welding current 10-100% of the main welding current activated when the trigger is held on to ‘latch’ the trigger before the main weld current is started. Once the trigger is released, the current will go through the upslope (3) period if it is set, to the main welding current (4).

● **Up slope setting indicator (3)**

When the trigger is activated, the welding current will increase gradually over the time selected up to the set main welding current (4). Unit(S) and setting range (0-10.0S).

- **TIG welding current setting indicator (4)**

Sets the main welding current . Unit(A) and setting range (10-320A/400A/500A).

- **Base current setting indicator (5)**

Only available when pulse mode (12) is selected. Sets the current of the low/ base pulse. Unit(A) and setting range (10-320A/400A/500A).

- **Down slope setting indicator (6)**

When the trigger is released, the welding current will reduce gradually over the time selected down to 0. This allows the operator to complete the weld without leaving a ‘crater’ at the end of the weld pool. Unit(S) and setting range (0-10.0S).

- **End current setting indicator (7)**

Available in 4T trigger mode only, sets a welding current 10-100% of the main welding current activated when the trigger is held on to ‘unlatch’ the trigger before the weld is finished. If downslope (6) is set, the current will go through the downslope period before going to the end current set. When the trigger is released, the arc will stop.

- **Post gasflow setting indicator (8)**

Controls the period of time the shielding gas continues to flow for after the arc is stopped. This protects the weld area and torch tungsten from contamination while it is still hot enough to react with atmospheric gases, after the weld is finished. Unit(S) and setting range (0-10.0S).

- **Pulse width setting indicator (9)**

Only available when pulse mode (12) is selected. Sets the time proportion as a percentage between the peak current and base current when using pulse mode. Neutral setting is 50%, the time period of the peak current and base current pulse is equal. Higher pulse duty setting will give greater heat input, while lower pulse duty will have the opposite effect. Unit(%) and setting range (5-95%).

- **Pulse frequency setting indicator (10)**

Only available when pulse mode (12) is selected. Sets the rate that the welding output alternates between the peak and base current settings. Unit(Hz) and setting range (0.5-999Hz).

- **Pulse mode ‘off’ indicator (11)**

- **Pulse mode ‘On’ indicator (12)**
- **Clean Width Area/ AC Balance Adjustment (13)**

Only available in AC welding mode (27,28,29). Adjusts the balance as a percentage between the forward and reverse current cycles when welding in AC output mode. The reverse part of the AC cycle gives the ‘cleaning’ effect on the weld material, while the forward cycle melts the weld material. Neutral setting is 0. Increased reverse cycle bias will give greater cleaning effect, less weld penetration and more heat in the torch tungsten, which gives the disadvantage of reducing the output current that can be used for a given tungsten size, to prevent the tungsten overheating. Increased forward cycle bias will give the opposite effect, less cleaning effect, greater weld penetration and less heat in the tungsten.

For maximum effectiveness, ideally the clean width/ AC balance should be set with as much forward cycle bias as possible, while still maintaining a sufficient level of oxidation removal for a contamination free weld pool. The cleaner non-ferrous metal is before welding, the more effective it is to weld. This effect can also be used to reduce heat in the tungsten, allowing use of a pointed tungsten tip shape for a more defined arc. setting range (-5+5).

- **AC Frequency Adjustment (14)**

Only available in AC welding mode (27,28,29). Increasing AC frequency will focus the shape of the arc, resulting in a tighter, more controlled arc causing increased penetration and less heated affected area for the same current setting. Slower frequency will result in a wider, softer arc shape. Unit(Hz) and setting range (50-250Hz).

9) AC/DC Output Modes

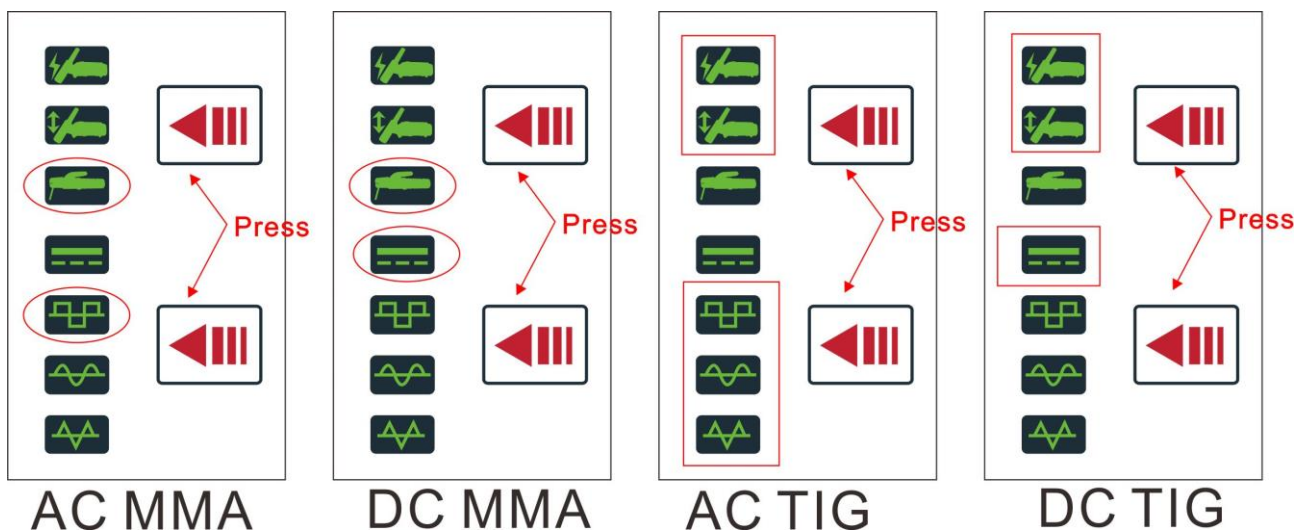

a. DC (Direct Current) Welding Output (26)

Suitable for TIG welding ferrous (iron based) metals such as mild steel and stainless steel, copper and titanium. TIG welding reactive metals such as Aluminium, Magnesium and Zinc requires AC (alternating current) output. When reactive metals are exposed to air they form an oxide layer that insulates the base metal and prevents welding current flowing, it also contaminates the weld pool. Reverse current flow is required to break through/ clean off this oxide layer so that welding can take place, while the current flow during the positive cycle does the majority of the heating of the weld pool area.

b. AC Triangle Wave Welding Output (27)

Reduced heat input for same current setting. Especially useful for welding thin metal.

c. AC Square Wave (28)

Focused arc for maximum penetration, fast travel speed with best directional control.

d. AC Sine Wave Welding Output (29)

Traditional AC TIG welding wave form. Quieter, ‘soft’ arc characteristic.

10) TIG Arc Starting Modes

TIG HF/ Lift Ignition Modes (31,32)

For TIG welding process, contact of the torch tungsten to the workpiece will cause contamination of the tungsten and the workpiece that will adversely affect the weld quality, especially when the tungsten is electrically energised.

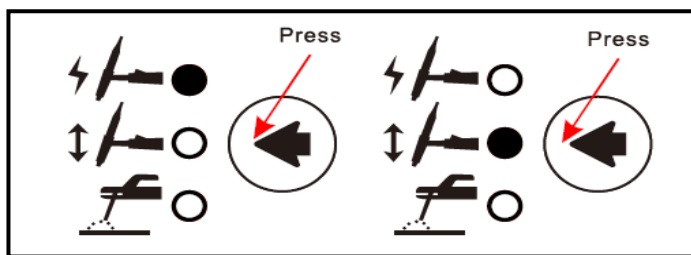

HF Ignition (High Frequency) sends a pulse of high energy electricity through the torch system that is capable of ‘jumping’ between the tungsten and the workpiece, ensuring arc starting without any contact between the tungsten and workpiece. The disadvantage of HF ignition is that the high energy electrical pulse creates significant electrical and radio signal interference, which limits its use around sensitive electronic equipment such as computers.

Lift TIG Ignition is a compromise that minimises tungsten contamination while eliminating the

electrical interference of HF startsystems. Lift arcstarting works by lightly resting the tungsten on the work piece, activating the torch trigger signal and then lifting the tungsten off. The control circuit will sense when the tungsten is removed from the work piece and send a low powered pulse of electricity through the tungsten that will cause the TIG arc to initiate. Because the tungsten is not 'live' when it is in contact with the work, contamination is minimised.

11) Program/Job Memory

The welding machine has 9 memory/ job spaces that parameters can be saved to for easy recall.



a. To access a saved program

- Long press (about 3s) the control knob (24) till the left digital display show 'Job', the right digital display show number (The number is adjustable from 1 to 9), and the 'Job' indicator will be lit.
- Adjust to the program number required by rotating the control knob. Once the program is accessed, it will automatically load.
- To return to normal parameter settings, press the control knob again or wait for 3 seconds (which will also load the selected program)

b. To save parameters set as a program

- Long press (about 3s) the control knob (24) till the left digital display show 'Job', the right digital display show number (The number is adjustable from 1 to 9), and the 'Job' indicator will be lit.
- Turn the knob to select the number for save the parameters.(For example, let's choose JOB 1)
- Press the knob to go to the parameters setting. Set the parameters that you want to save to JOB number 1.
- Long press (about 3s) the knob till the left digital display show 'Job', and the right digital display show number (The number is adjustable from 1 to 9). Then the parameters is saved to JOB 1.
- Press the knob or wait for 3 seconds, then you can welding. The welding parameters will be

JOB 1.

c. How to delete the saved parameters we saved?

It can be only replaced by new parameters. Just repeat the above steps of how to save parameters and choose the Job number that you want to replace.

12) Pulse welding

Pulse welding mode switches the welding output between a high and low current output in a cyclical manner. When used correctly this function has substantial benefits in the TIG welding process including greater weld penetration for less work heat input and greater control of the weld pool.

The basic theory for setting the base current using pulse mode is that the base current should be sufficient to maintain the existing molten weld pool, while the peak current is sufficient to melt new metal in order to move/ expand the molten weld pool. Increased pulse frequency will have the effect of making the arc more tightly focused which is useful for fine stainless work and similar.

Pulsing can also be used to help move the weld pool, this technique is useful for welding out of position or with materials that have higher viscosity weld pool. Higher pulse duty setting will give greater heat input, while lower pulse duty will have the opposite effect.

13) Water Cooling

The welding machine is supplied standard with water cooled TIG torch. The standard trolley package includes the integrated water cooler. The correct coolant to use is a mixture of Mono Propylene Glycol and water in a 1:3 ratio (25% propylene glycol. Pure water may be used as a coolant liquid, though it is not recommended for the long term reliability of the water cooling system as it does not have the lubrication properties of glycol and does not provide protection against freezing. Ready to use coolant fluid can be purchased from authorised Strata dealers.

Do not operate a water cooled torch without the cooling system operating!

§3.2 Power supply input Connection

The TIG welding machine is designed to operate on a 3phase 380V AC power supply.

When the power supply voltage is over the safe work voltage, there are over voltage and under voltage protection inside the welder, the alarm light will on, at the same time, the current output will

be cut off.

If the power supply voltage continually goes beyond the safe work voltage range, it will shorten the welder life-span. The below measures can be used:

- Change the power supply input net. Such as, connect the welder with the stable power supply voltage of distributor;
- Induce the machines using power supply in the same time;
- Set the voltage stabilization device in the front of power cable input.

§3.3 Installation & Operation for MMA Welding

§3.3.1 Set up installation for MMA Welding

Connection of Output Cables

Two sockets are available on this welding machine. For MMA welding the electrode holder is shown be connected to the positive socket, while the earth lead (work piece) is connected to the negative socket, this is known as DCEP. However various electrodes require a different polarity for optimum results and careful attention should be paid to the polarity, refer to the electrode manufacturers information for the correct polarity.

DCEP: Electrode connected to “+” output socket.

DCEN: Electrode connected to “-” output socket.

MMA (DC): Choosing the connection of DCEN or DCEP according to the different electrodes.

Please refer to the electrode manual.

MMA (AC): No requirements for polarity connection.

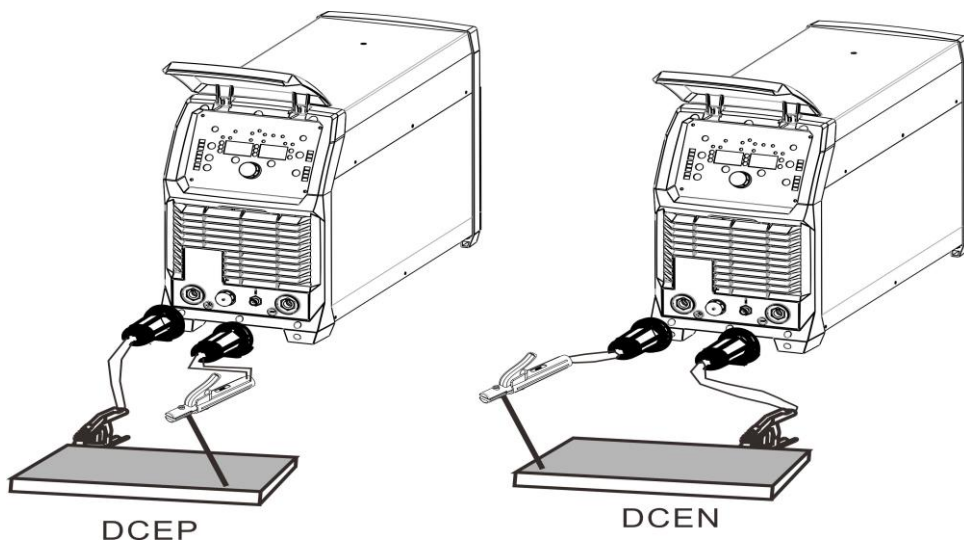

- (1) Connect the earth lead to “-” , tighten clockwise;
- (2) Connect the earth clamp to the work piece. Contact with the work piece must be firm contact with clean, bare metal, with no corrosion, paint or scale at the contact point.
- (3) Connect the electrode lead to “+” , tighten clockwise;
- (4) Each machine is equipped with a power cable should be based on the input voltage welding power cable connected to the appropriate position, not to pick the wrong voltage;
- (5) With the corresponding input power supply terminal or socket good contact and prevent oxidation;
- (6) With a multi meter measure the input voltage is within the fluctuation range;
- (7) The power ground is well grounded.

§3.3.2 Operation for MMA Welding

- (1) According to the above method to install is correct, turn the power switch, so that the power switch is “ON” position, then the power indicator light, the fan comes on, the device work properly.
- (2) Set to ‘MMA’ welding mode.
- (3) Set the AC/DC output modes to ‘AC’ or ‘DC’.
- (4) Set the welding parameters as required using the parameters control knob (following the instructions in the previous section).
- (5) Place the electrode into the electrode holder and clamp tight.
- (6) Strike the electrode against the work piece to create and arc and hold the electrode steady to maintain the arc.
- (7) Commence welding. If necessary, readjust the Welding parameters control knob to obtain the welding condition required.
- (8) After completion of welding the Power Source should be left turned ON for 2 to 3 minutes. This allows the fan to run and cool the internal components.
- (9) Switch the ON/OFF Switch (located on the rear panel) to the OFF position.

NOTE:

- Note the polarity of wiring, the general DC welding wire in two ways. Selected according to the technical requirements of welding the appropriate connection, if you choose incorrectly will result in arc instability and spatter large adhesion and other phenomena, such cases can

be quickly reversed to joints.

- If the work piece distance from the welding machine, the second line (electrode holder and ground) is longer, so choose the appropriate conductor cross-sectional area should be larger to reduce cable voltage drop.

§3.3.3 MMA Welding

One of the most common types of arc welding is manual metal arc welding (MMA) or stick welding. An electric current is used to strike an arc between the base material and a consumable electrode rod or ‘stick’. The electrode rod is made of a material that is compatible with the base material being welded and is covered with a flux that gives off gaseous vapours that serve as a shielding gas and providing a layer of slag, both of which protect the weld area from atmospheric contamination. The electrode core itself acts as filler material the residue from the flux that forms slag covering over the weld metal must be chipped away after welding.

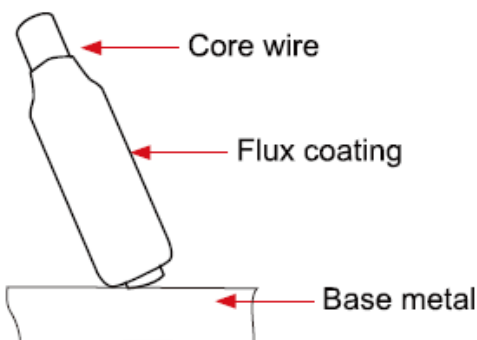
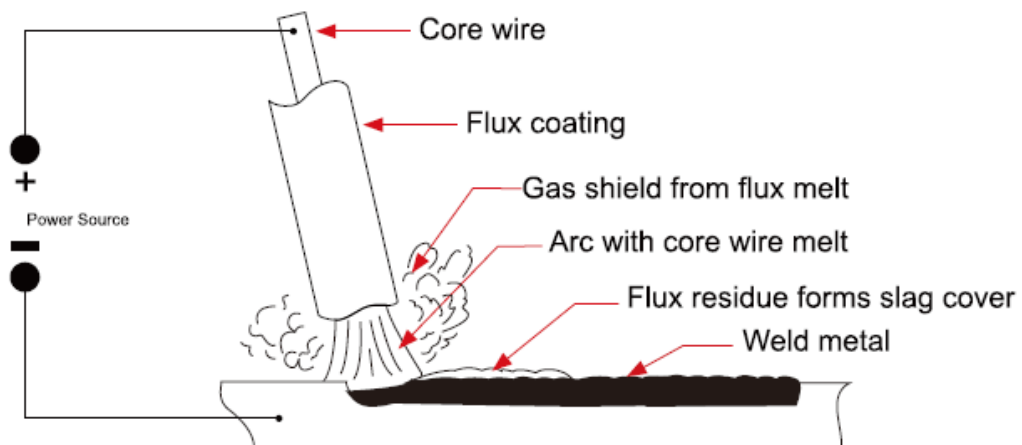

- The arc is initiated by momentarily touching the electrode to the base metal.
- The heat of the arc melts the surface of the base metal to form a molten pool at the end of the electrode.
- The melted electrode metal is transferred across the arc into the molten pool and becomes the deposited weld metal.
- The deposit is covered and protected by a slag which comes from the electrode coating.
- The arc and the immediate area are enveloped by an atmosphere of protective gas.

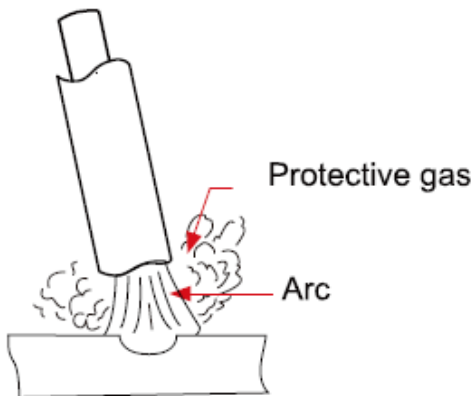

Manual metal arc (stick) electrodes have a solid metal wire core and a flux coating. These electrodes are identified by the wire diameter and by a series of letters and numbers. The letters and numbers identify the metal alloy and the intended use of the electrode.

The **Metal Wire Core** works as conductor of the current that maintains the arc. The core wire melts and is deposited into the welding pool.

The covering on a shielded metal arc welding electrode is called **Flux**.

The flux on the electrode performs many different functions.

These include:

- producing a protective gas around the weld area
- providing fluxing elements and deoxidizer
- creating a protective slag coating over the weld as it cools
- establishing arc characteristics
- adding alloying elements.

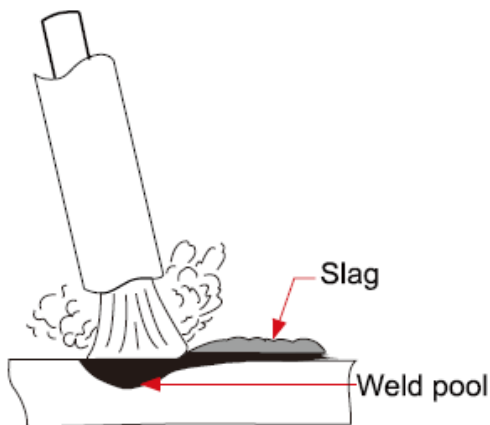

Covered electrodes serve many purposes in addition to filler metal to the molten pool. These additional functions are provided mainly by the covering on the electrode.

§3.3.4 MMA Welding Fundamentals

■ Electrode Selection

As a general rule, the selection of an electrode is straight forward, in that it is only a matter of selecting an electrode of similar composition to the parent metal. However, for some metals there is a choice of several electrodes, each of which has particular properties to suit specific classes of work. It is recommended to consult your welding supplier for the correct selection of electrode.

■ **Electrode Size**

Average Thickness of Material	Maximum Recommended Electrode Diameter
1.0-2.0 mm	2.5 mm
2.0-5.0 mm	3.2 mm
5.0-8.0 mm	4.0 mm
>8.0 mm	5.0 mm

The size of the electrode generally depends on the thickness of the section being welded, and the thicker the section the larger the electrode required. The table gives the maximum size of electrodes that maybe used for various thicknesses of section base on using a general purpose type 6013 electrode.

■ **Welding Current (Amperage)**

Electrode Size ømm	Current Range (Amps)
2.5 mm	60-95
3.2 mm	100-130
4.0 mm	130-165
5.0 mm	165-260

Correct current selection for a particular job is an important factor in arc welding. With the current set too low, difficulty is experienced in striking and maintaining a stable arc. The electrode tends to stick to the work, penetration is poor and beads with a distinct rounded profile will be deposited. Too high current is accompanied by overheating of the

electrode resulting undercut and burning through of the base metal and producing excessive spatter. Normal current for a particular job may be considered as the maximum, which can be used without burning through the work, over-heating the electrode or producing a rough spattered surface. The table shows current ranges generally recommended for a general purpose type 6013 electrode.

■ **Arc Length**

To strike the arc, the electrode should be gently scraped on the work until the arc is established. There is a simple rule for the proper arc length; it should be the shortest arc that gives a good surface to the weld. An arc too long reduces penetration, produces spatter and gives a rough surface finish to the weld. An excessively short arc will cause sticking of the electrode and result in poor quality welds. General rule of thumb for down hand welding is to have an arc length no greater than the diameter of the core wire.

■ Electrode Angle

The angle that the electrode makes with the work is important to ensure a smooth, even transfer of metal. When welding in down hand, fillet, horizontal or overhead the angle of the electrode is generally between 5 and 15 degrees towards the direction of travel. When vertical up welding the angle of the electrode should be between 80 and 90 degrees to the work piece.

■ Travel Speed

The electrode should be moved along in the direction of the joint being welded at a speed that will give the size of run required. At the same time, the electrode is fed downwards to keep the correct arc length at all times. Excessive travel speeds lead to poor fusion, lack of penetration etc, while too slow a rate of travel will frequently lead to arc instability, slag inclusions and poor mechanical properties.

■ Material and Joint Preparation

The material to be welded should be clean and free of any moisture, paint, oil, grease, mill scale, rust or any other material that will hinder the arc and contaminate the weld material. Joint preparation will depend on the method used include sawing, punching, shearing, machining, flame cutting and others. In all cases edges should be clean and free of any contaminants. The type of joint will be determined by the chosen application.

§3.3.5 MMA Welding trouble shooting

The following chart addresses some of the common problems of MMA welding. In all cases of equipment malfunction, the manufacturer's recommendations should be strictly adhered to and followed.

NO.	Trouble	Possible Reason	Suggested Remedy
1	No arc	Incomplete welding circuit	Check earth lead is connected. Check all cable connections.
		No power supply	Check that the machine is switched on and has a power supply
		Wrong mode selected	Check the MMA selector switch is selected

2	Porosity – small cavities or holes resulting from gas pockets in weld metal	Arc length too long	Shorten the arc length
		Work piece dirty, contaminated or moisture	Remove moisture and materials like paint, grease, oil, and dirt, including mill scale from base metal
		Damp electrodes	Use only dry electrodes
3	Excessive Spatter	Amperage too high	Decrease the amperage or choose a larger electrode
		Arc length too long	Shorten the arc length
4	Weld sits on top, lack of fusion	Insufficient heat input	Increase the amperage or choose a larger electrode
		Work piece dirty, contaminated or moisture	Remove moisture and materials like paint, grease, oil, and dirt, including mill scale from base metal
		Poor welding technique	Use the correct welding technique or seek assistance for the correct technique
5	Lack of penetration	Insufficient heat input	Increase the amperage or choose a larger electrode
		Poor welding technique	Use the correct welding technique or seek assistance for the correct technique
		Poor joint preparation	Check the joint design and fit up, make sure the material is not too thick. Seek assistance for the correct joint design and fit up
6	Excessive penetration - burn through	Excessive heat input	Reduce the amperage or use a smaller electrode
		Incorrect travel speed	Try increasing the weld travel speed
7	Uneven weld appearance	Unsteady hand, wavering hand	Use two hands where possible to steady up, practise your technique
8	Distortion – movement of base metal during welding	Excessive heat input	Reduce the amperage or use a smaller electrode
		Poor welding technique	Use the correct welding technique or seek assistance for the correct technique
		Poor joint preparation and or joint design	Check the joint design and fit up, make sure the material is not too thick. Seek assistance for the correct joint design and fit up
9	Electrode welds with different or unusual arc characteristic	Incorrect polarity	Change the polarity, check the electrode manufacturer for correct polarity

§3.4 Installation & Operation for TIG Welding

§3.4.1 Set up installation for TIG Welding

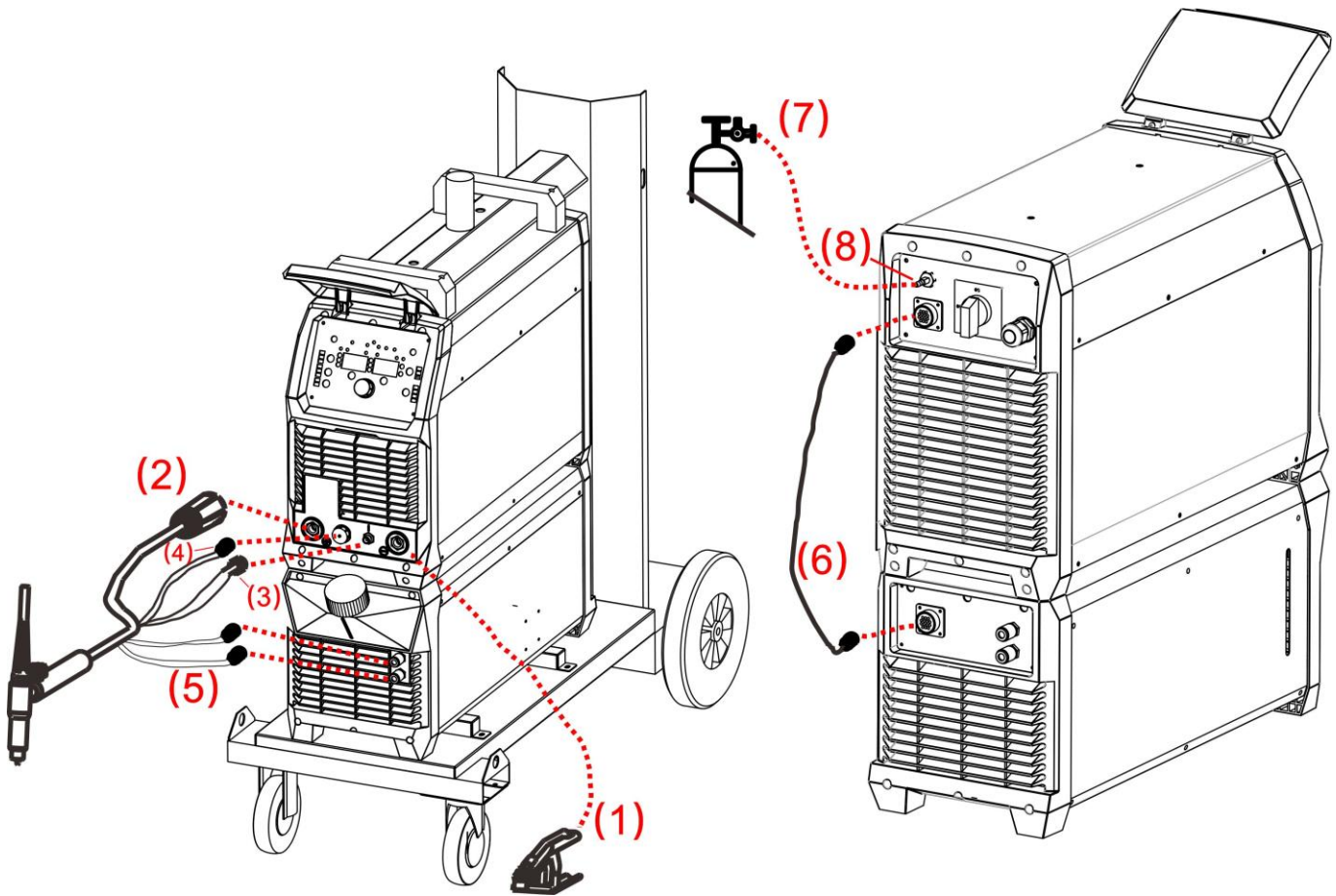

Switch the ON/OFF Switch (located on the rear panel) to OFF.

- (1) Connect the earth lead to “+”, tighten clockwise; Connect the earth clamp to the work piece. Contact with the work piece must be firm contact with clean, bare metal, with no corrosion, paint or scale at the contact point.
- (2) Connect the TIG torch cable to “-”, tighten clockwise.
- (3) Connect TIG torch gas connection to the TIG gas outlet , ensuring all connections are tight.
- (4) Connect TIG torch remote plug to remote socket, ensuring all connections are tight.
- (5) If using a water cooled torch, Connect the water cooling lines from the TIG torch to the front of the water cooler, ensuring the red and blue return and supply lines match the connectors.
- (6) If using a water cooled torch, connect the water cooler interface cable from the rear of the power source to the rear of the water cooler.
- (7) Connect the gas regulator to the Gas Cylinder and connect the gas line to the Gas Regulator.
- (8) Connect the gas line to the machine inlet gas connector via the quick push lock connector

located on the rear panel. **Check for Leaks!**

- (9) Open gas cylinder valve and adjust regulator, flow should be between 5-10 l/min depending on application. Re-check regulator flow pressure with torch valve open as static gas flow setting may drop once gas is flowing.
- (10) Each machine is equipped with a power cable should be based on the input voltage welding power cable connected to the appropriate position, not to pick the wrong voltage;
- (11) With the corresponding input power supply terminal or socket good contact and prevent oxidation;
- (12) With a multi meter measure the input voltage is within the fluctuation range;
- (13) The power ground is well grounded.

NOTE:

- Secure the gas cylinder in an upright position by chaining them to a stationary support to prevent falling or tipping.

§3.4.2 Operation for TIG Welding

- (1) According to the above method to install is correct, turn the power switch to the “ON” position, the power L.E.D. light should illuminate, the fan comes on, the device work properly.
- (2) Set the welding mode to ‘Lift TIG’ or ‘HF TIG’.
- (3) If a water cooled torch and water cooler is used, check the water cooler has sufficient coolant level and all connections are firmly secured, then switch on the water cooler power switch on the rear of the water cooler. Set the water/air setting button (14) to ‘water (16)’. The water cooler should now start operating. If using an air cooled torch, set the button (14) to ‘air’ setting (15).
- (4) Set the AC/DC output modes to ‘AC’ or ‘DC’.
- (5) Set the welding parameters as required using the parameters control knob (following the instructions in the previous section).
- (6) The tungsten must be ground to a blunt point in order to achieve optimum welding results. It is critical to grind the tungsten electrode in the direction the grinding wheel is turning.
- (7) Install the tungsten with approximately 3mm to 7mm sticking out from the gas cup, ensuring you have correct sized collet.

- (8) Tighten the back cap.
- (9) Commence welding. If necessary, readjust the parameters control knob to obtain the welding condition re-quired.
- (10)After completion of welding the Power Source should be left turned ON for 2 to 3 minutes.
This allows the fan to run and cool the internal components.
- (11)Switch the ON/OFF Switch (located on the rear panel) to the OFF.

§3.4.3 Remote current control

The welding machine can accept remote current control from a potentiometer/ analogue signal or a digital up/down button signal. Potentiometer remote control will change the current from the 5A minimum to the maximum set using the machine current control .Using an up/ down button remote signal, the current may be increased or decreased in 1A increments, or ‘scrolls’ up to 30A at a time if the button is held down. This is very useful for precision work.

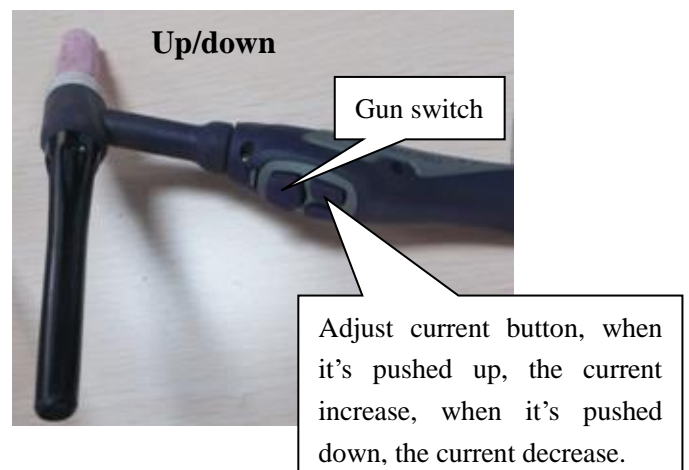
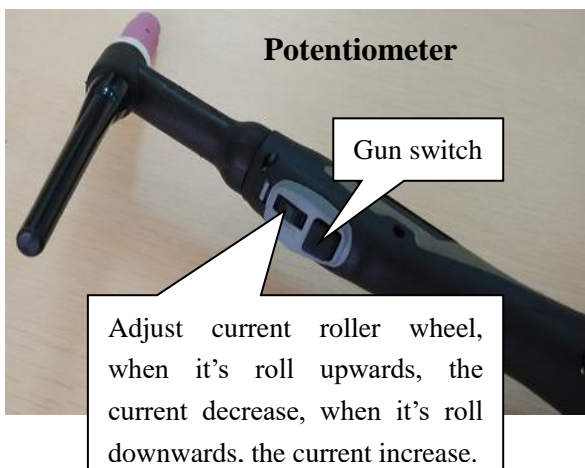

12 Pin Remote Plug Connection

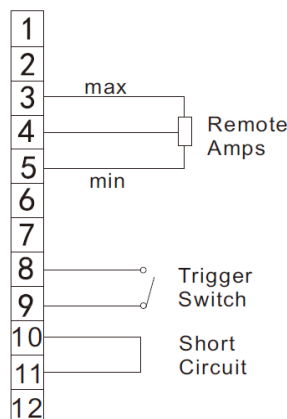
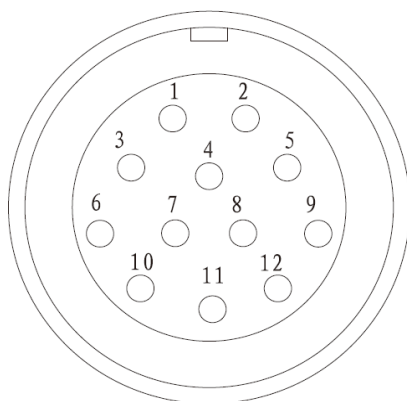

Potentiometer

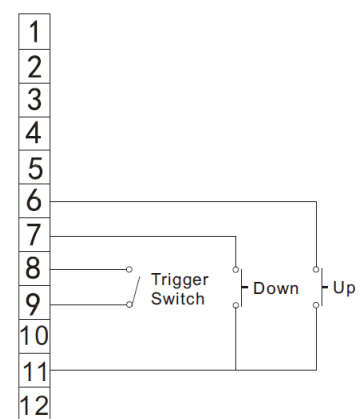

Up/down

Socket Pin	Function	
	Potentiometer	Up/down
1	Not connected	Not connected
2	Not connected	Not connected
3	10k ohm (maximum) connection to 10k ohm remote control potentiometer	Not connected
4	Wiper arm connection to 10k ohm remote control potentiometer	Not connected
5	Zero ohm (minimum) connection to 10k ohm remote control potentiometer	Not connected
6	Not connected	The button of "UP" input
7	Not connected	The button of "DOWN" input
8	Trigger Switch Input	Trigger Switch Input
9	Trigger Switch Input	Trigger Switch Input
10	Be shorted with 11	Not connected
11	Be shorted with 10	The button of "UP"& "DOWN" input
12	Not connected	Not connected

§3.4.4 Tig Welding Techniques

TIG Welding Fusion Technique

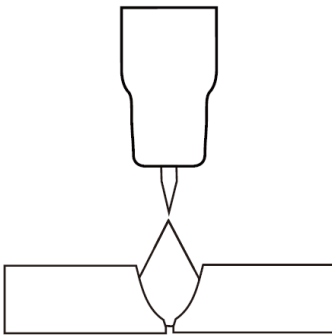

Manual TIG welding is often considered the most difficult of all the welding processes. Because the welder must maintain a short arc length, great care and skill are required to prevent contact between the electrode and the work piece. Similar to Oxygen Acetylene torch welding, Tig welding normally requires two hands and in most instances requires the welder to manually feed a filler wire into the

weld pool with one hand while manipulating the welding torch in the other. However, some welds combining thin materials can be accomplished without filler metal like edge, corner, and butt joints. This is known as Fusion welding where the edges of the metal pieces are melted together using only the heat and arc force generated by the TIG arc. Once the arc is started the tungsten is held in place until a weld pool is created, a circular movement of the tungsten will assist in creating a weld pool of the desired size. Once the weld pool is established tilt the torch at about a 75° angle and move smoothly and evenly along the joint while fusing the materials together.

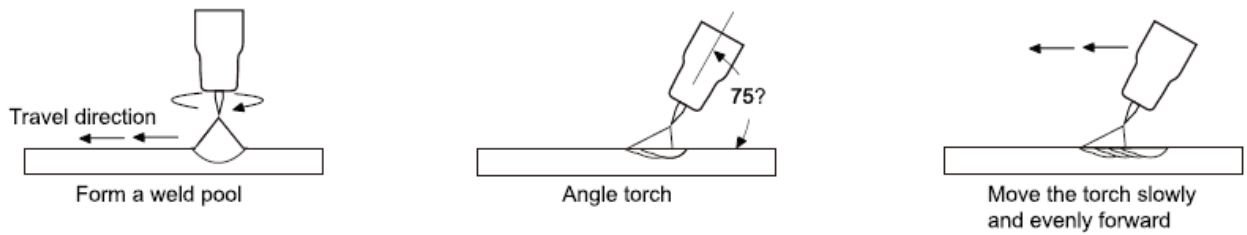

TIG Welding with Filler Wire Technique

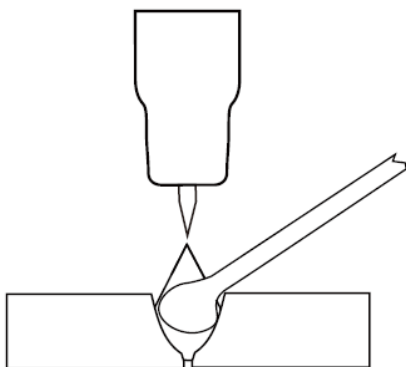

It is necessary in many situations with TIG welding to add a filler wire into the weld pool to build up weld reinforcement and create a strong weld. Once the arc is started the torch tungsten is held in place until a weld pool is created, a circular movement of the tungsten will assist in creating a weld pool of the desired size. Once the weld pool is established tilt the torch at about a 75° angle and move smoothly and evenly along the joint.

The filler metal is introduced to the leading edge of the weld pool. The filler wire is usually held at about a 15° angle and fed into the leading edge of the molten pool, the arc will melt the filler wire into the weld pool as the torch is moved forward. Also a dabbing technique can be used to control the amount of filler wire added, the wire is fed into the molten pool and retracted in a repeating sequence as the torch is moved slowly and evenly forward. It is important during the welding to keep the molten end of the filler wire inside the gas shield as this protects the end of the wire from being oxidised and contaminating the weld pool.

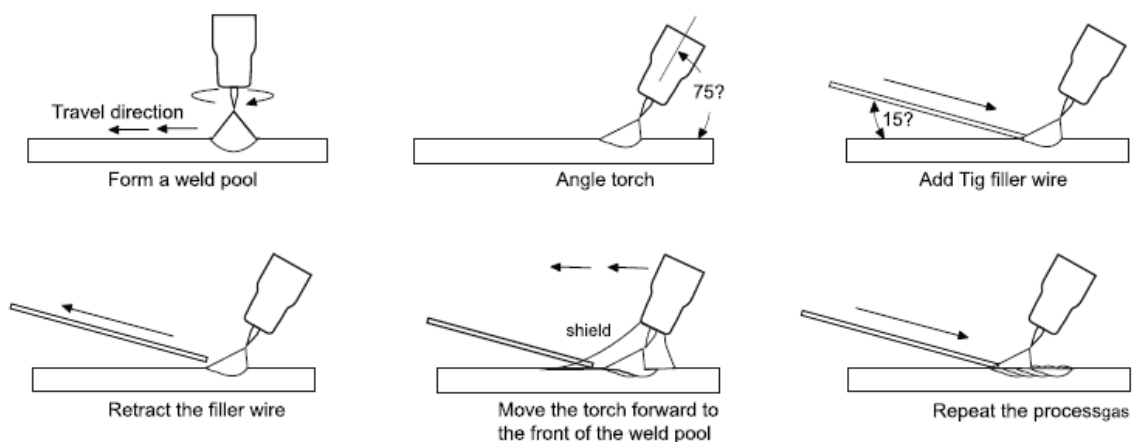

§3.4.5 Electrodes

Tungsten Electrodes

Tungsten is a rare metallic element used for manufacturing TIG welding electrodes. The TIG process relies on tungsten's hardness and high-temperature resistance to carry the welding current to the arc. Tungsten has the highest melting point of any metal, 3,410 degrees Celsius. Tungsten electrodes are non-consumable and come in a variety of sizes, they are made from pure tungsten or an alloy of tungsten and other rare earth elements. Choosing the correct tungsten depends on the material being welded, amps required and whether you are using AC or DC welding current. Tungsten electrodes are colour-coded at the end for easy identification.

Thoriated

Thoriated tungsten electrodes (AWS classification EWTh-2) contain a minimum of 97.30 percent tungsten and 1.70 to 2.20 percent thorium and are called 2 percent thoriated. They are the most commonly used electrodes today and are preferred for their longevity and ease of use.

Thorium increases the electron emission qualities of the electrode, which improves arc starts and allows for a higher current-carrying capacity. This electrode operates far below its melting temperature, which results in a considerably lower rate of consumption and eliminates arc wandering. Compared with other electrodes, thoriated electrodes deposit less tungsten into the weld puddle, so they cause less weld contamination.

Thorium is a low-level radioactive hazard and many users have switched to other alternatives. Thorium is an alpha emitter but when enclosed in a tungsten matrix, the risks are negligible. Thus holding a stick of Thoriated tungsten in your hand should not pose a great threat unless a welder has open cuts on their skin. Thoriated tungsten should not get in contact with open cuts or wounds. The more significant danger to welders can occur when thorium oxide gets into the lungs. This can happen from the exposure to vapours during welding or from ingestion of material/ dust in the grinding of the tungsten. Follow the manufacturer's warnings, instructions, and the Safety Data Sheet (SDS) for its use.

E3 (Color Code: Purple)

E3 tungsten electrodes (AWS classification EWG) contain a minimum of 98% percent tungsten and up to 1.5 percent Lanthanum and small percentages of Zirconium and Yttrium they are called E3 Tungsten. E3 Tungsten Electrodes provide conductivity similar to that of thoriated electrodes. Typically, this means that E3 Tungsten Electrodes are exchangeable with thoriated

electrodes without requiring significant welding process changes. E3 deliver superior arc starting, electrode lifetime, and overall cost-effectiveness. When E3 Tungsten Electrodes are compared with 2% thoriated tungsten, E3 requires fewer re-grinds and provides a longer overall lifetime. Tests have shown that ignition delay with E3 Tungsten Electrodes actually improves over time, while 2% thoriated tungsten starts to deteriorate after only 25 starts. At equivalent energy output, E3 Tungsten Electrodes run cooler than 2% thoriated tungsten, thereby extending overall tip lifetime. E3 Tungsten Electrodes work well on AC or DC. They can be used DC electrode positive or negative with a pointed end, or balled for use with AC power sources.

Ceriated (Color Code: Orange) 

Ceriated tungsten electrodes (AWS classification EWCe-2) contain a minimum of 97.30 percent tungsten and 1.80 to 2.20percent cerium and are referred to as 2 percent ceriated. Ceriated tungstens perform best in DC welding at low current settings. They have excellent arc starts at low amperages and become popular in such applications as orbital tube welding, thin sheet metal work. They are best used to weld carbon steel, stainless steel, nickel alloys, and titanium, and in some cases it can replace 2 percent thoriated electrodes. Ceriated tungsten is best suited for lower amperages it should last longer than Thoriated tungsten higher amperage applications are best left to Thoriated or Lanthanated tungsten.

Lanthanated (Color Code: Gold) 

Lanthanated tungsten electrodes (AWS classification EWLa-1.5) contain a minimum of 97.80 percent tungsten and 1.30percent to 1.70 percent lanthanum, and are known as 1.5 percent lanthanated. These electrodes have excellent arc starting, a low burn off rate, good arc stability, and excellent re-ignition characteristics. Lanthanated tungstens also share the conductivity characteristics of 2 percent thoriated tungsten. Lanthanated tungsten electrodes are ideal if you want to opti-mise your welding capabilities. They work well on AC or DC electrode negative with a pointed end, or they can be balled for use with AC sine wave power sources. Lanthanated tungsten maintains a sharpened point well, which is an advantage for welding steel and stainless steel on DC or AC from square wave power sources.

Zirconiated (Color Code: White) 

Zirconiated tungsten electrodes (AWS classification EWZr-1) contain a minimum of 99.10 percent tungsten and 0.15 to 0.40percent zirconium. Most commonly used for AC welding

Zirconiated tungsten produces a very stable arc and is resistant to tungsten spitting. It is ideal for AC welding because it retains a balled tip and has a high resistance to contamination. Its current-carrying capacity is equal to or greater than that of thoriated tungsten. Zirconiated tungsten is not recommended for DC welding.

Tungsten Electrodes Rating for Welding Currents

Tungsten Diameter mm	DC Current Amps Torch Negative 2% Thoriated	AC Current Amps Un-Balanced Wave 0.8% Zirconiated	AC Current Amps Balanced Wave 0.8% Zirconiated
1.0mm	15-80	15-80	20-60
1.6mm	70-150	70-150	60-120
2.4mm	150-250	140-235	100-180
3.2mm	250-400	225-325	160-250
4.0mm	400-500	300-400	200-320

Tungsten Preparation

Always use **DIAMOND** wheels when grinding and cutting. While tungsten is a very hard material, the surface of a diamond wheel is harder, and this makes for smooth grinding. Grinding without diamond wheels, such as aluminium oxide wheels, can lead to jagged edges, imperfections, or poor surface finishes not visible to the eye that will contribute to weld inconsistency and weld defects.

Always ensure to grind the tungsten in a longitudinal direction on the grinding wheel. Tungsten electrodes are manufactured with the molecular structure of the grain running lengthwise and thus grinding crosswise is “grinding against the grain.” If electrodes are ground crosswise, the electrons have to jump across the grinding marks and the arc can start before the tip and wander. Grinding longitudinally with the grain, the electrons flow steadily and easily to the end of the tungsten tip. The arc starts straight and remains narrow, concentrated, and stable.



Electrode Tip/Flat

The shape of the tungsten electrode tip is an important process variable in precision arc welding. A good selection of tip/flat size will balance the need for several advantages. The bigger the flat, the more likely arc wander will occur and the more difficult it will be to arc start. However, increasing the flat to the maximum level that still allows arc start and eliminates arc wander will improve the weld penetration and increase the electrode life. Some welders still grind electrodes to a sharp point, which makes arc starting easier. However, they risk decreased welding performance from melting at the tip and the possibility of the point falling off into the weld pool.



Electrode Included Angle/Taper

DC Welding Tungsten electrodes for DC welding should be ground longitudinally and concentrically with diamond wheels to a specific included angle in conjunction with the tip/flat preparation. Different angles produce different arc shapes and offer different weld penetration capabilities. In general, blunter electrodes that have a larger included angle provide the following benefits:

- Last Longer
- Have better weld penetration
- Have a narrower arc shape
- Can handle more amperage without eroding.

Sharper electrodes with smaller included angle provide:

- Offer less arc weld
- Have a wider arc
- Have a more consistent arc

The included angle determines weld bead shape and size. Generally, as the included angle increases, penetration increases and bead width decreases.



Tungsten Electrode Preparation

Tungsten Diameter	Diameter at the Tip - mm	Constant Included Angle - Degrees	Current Range Amps	Current Range Pulsed Amps
1.0mm	.250	20	05 - 30	05 - 60
1.6mm	.500	25	08 - 50	05 - 100
1.6mm	.800	30	10 - 70	10 - 140
2.4mm	.800	35	12 - 90	12 - 180
2.4mm	1.100	45	15 - 150	15 - 250
3.2mm	1.100	60	20 - 200	20 - 300
3.2mm	1.500	90	25 - 250	25 - 350

§3.4.6 TIG Welding trouble shooting

The following chart addresses some of the common problems of TIG welding. In all cases of equipment malfunction, the manufacturer's recommendations should be strictly adhered to and followed.

NO.	Trouble	Possible Reason	Suggested Remedy
1	Tungsten burning away quickly	Incorrect Gas or No Gas	Use pure Argon. Check cylinder has gas, connected, turned on and torch valve is open
		Inadequate gas flow	Check the gas is connected, check hoses, gas valve and torch are not restricted.
		Back cap not fitted correctly	Make sure the torch back cap is fitted so that the o-ring is inside the torch body
		Torch connected to DC +	Connect the torch to the DC- output terminal
		Incorrect tungsten being used	Check and change the tungsten type if necessary
		Tungsten being oxidised after weld is finished	Keep shielding gas flowing 10–15 seconds after arc stoppage. 1 second for each 10amps of weld current.
		Tungsten melting back into the nozzle on AC welding	Check that correct type of tungsten is being used. Check the balance control is not set too high on the balance-reduce to lower setting

2	Contaminated tungsten	Touching tungsten into the weld pool	Keep tungsten from contacting weld puddle. Raise the torch so that the tungsten is off of the work piece 2 - 5mm
		Touching the filler wire to the tungsten	Keep the filler wire from touching the tungsten during welding, feed the filler wire into the leading edge of the weld pool in front of the tungsten
		Tungsten melting into the weld pool	Check that correct type of tungsten is being used. Too much current for the tungsten size so reduce the amps or change to a larger tungsten
3	Porosity - poor weld appearance and colour	Wrong gas / poor gas flow /gas leak	Use pure argon. Gas is connected, check hoses, gas valve and torch are not restricted. Set the gas flow between 6-12 l/min. Check hoses and fittings for holes, leaks et
		Contaminated base metal	Remove moisture and materials like paint, grease, oil, and dirt from base metal
		Contaminated filler wire	Remove all grease, oil, or moisture from filler metal
		Incorrect filler wire	Check the filler wire and change if necessary
4	Yellowish residue / smoke on the alumina nozzle & discoloured tungsten	Incorrect Gas	Use pure Argon gas
		Inadequate gas flow	Set the gas flow between 10 - 15 l/min flow rate
		Inadequate post flow gas	Increase the post flow gas time
		Alumina gas nozzle too small	Increase the size of the alumina gas nozzle
5	Unstable Arc during welding	Torch connected to DC +	Connect the torch to the DC- output terminal
		Contaminated base metal	Remove materials like paint, grease, oil, and dirt, including mill scale from base metal.
		Tungsten is contaminated	Remove 10mm of contaminated tungsten and re grind the tungsten
		Arc length too long	Lower torch so that the tungsten is off of the work piece 2 - 5mm
6	HF present but no welding power	Incomplete welding circuit	Check earth lead is connected. Check all cable connections. If using a water cooled torch check that the power cable is separated.

6	HF present but no welding power	No gas	Check the gas is connected and cylinder valve open, check hoses, gas valve and torch are not restricted Set the gas flow between 10 - 15 l/min
		Tungsten melting into the weld pool	Check that correct type of tungsten is being used. Too much current for the tungsten size so reduce the amps or change to a larger tungsten
7	Arc wanders during welding	Poor gas flow	Check and set the gas flow between 10 - 15 l/min flow rate
		Incorrect arc length	Lower torch so that the tungsten is off of the work piece 2 - 5mm
		Tungsten incorrect or in poor condition	Check that correct type of tungsten is being used. Remove 10mm from the weld end of the tungsten and re sharpen the tungsten
		Poorly prepared tungsten	Grind marks should run lengthwise with tungsten, not circular. Use proper grinding method and wheel.
		Contaminated base metal or filler wire	Remove contaminating materials like paint, grease, oil, and dirt, including mill scale from base metal. Remove all grease, oil, or moisture from filler metal
		Incorrect filler wire	Check the filler wire and change if necessary
8	Arc difficult to start or will not start welding	Incorrect machine set up	Check machine set up is correct
		No gas, incorrect gas flow	Check the gas is connected and cylinder valve open, check hoses, gas valve and torch are not restricted. Set the gas flow between 10 - 15 l/min flow rate
		Incorrect tungsten size or type	Check and change the size and or the tungsten if required
		Tungsten is contaminated	Remove 10mm of contaminated tungsten and regrind the tungsten
		Loose connection	Check all connectors and tighten
		Earth clamp not connected to work	Connect the earth clamp directly to the work piece wherever possible
		Loss of high frequency	Check torch and cables for cracked insulation or bad connections.

§3.5 Remote control Configuration

§3.5.1 Wireless remote control Configuration

The welding machine can be configured to communicate exclusively with wireless foot pedal or remote control panel. This is done by a simple process of synchronising the wireless remote control and the machine frequencies. Each interface frequency assigned is unique, so it is possible to use several wireless control systems/machines in the same area with no problems. The direct range of the wireless control system is approximately 100m, this will be affected by the physical location of the machine and the remote control.

Synchronization of the remote control with the welding machine, follow these instructions:

- 1) Ensure the welding power supply is switched off.
- 2) Press and hold the parameter select/adjust knob on the front panel of the power supply (2-4 seconds) while at the same time turning the machine ON using the ON-OFF switch on the back of the welding power supply.
- 3) When the display on the front panel of the power supply is blank, release the control knob. Turn on the remote control or foot pedal while at the same time pressing any buttons on the remote control panel or foot pedal, the digital meter on the front panel of the welding power supply flick twice to indicate the synchronization is successful and complete.(Synchronization has to accomplish in 10s after the display is blank.)
- 4) Switch the machine off and back on again to start welding operation.
- 5) If the operation is unsuccessful, repeat steps 1 to 4.
- 6) During operation, the front panel control on the power supply is still functional but the remote control panel or foot pedal has higher priority level.
- 7) When the remote control panel or foot pedal is idles for 10 seconds, it will automatically go into “sleep” mode.
- 8) Only front Panel Control is active when wireless remote control or foot pedal is in “sleep” mode. Any operation on the wireless remote control panel or foot pedal will “wake it up and resumes control of the machine.

Reset the remote control, follow these instructions:

- 1) Ensure the welding power supply is switched off.
- 2) Press and hold the parameter select/adjust knob on the front panel of the power supply (about 10

seconds) while at the same time turning the machine ON using the ON-OFF switch on the back of the welding power supply.

- 3) When the digital meter on the front panel of the power supply displays “rSt” to indicate the reset is successful and complete.

§3.5.2 Wire foot pedal Configuration

- When plug the twelve-lead aero-socket of pedal switch in it. Welder will identify the pedal switch, the welding current knob on the front panel will can't use, and only 2T can be selected.
- When use the adjustment knob of max-welding current beside the pedal, can set the max-current you want.

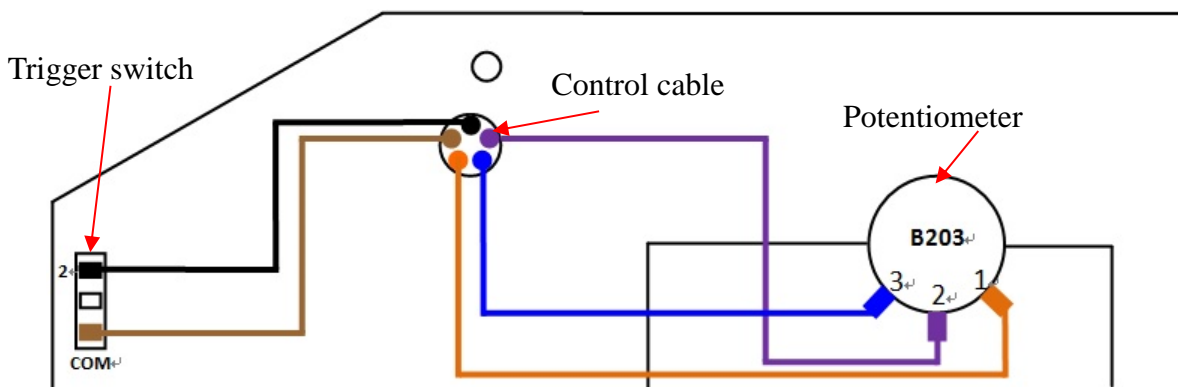

Socket Pin	Function
1	Be shorted with 2
2	Be shorted with 1
3	20k ohm (maximum) connection to 20k ohm remote control potentiometer
4	Wiper arm connection to 20k ohm remote control potentiometer
5	Zero ohm (minimum) connection to 20k ohm remote control potentiometer
6	Not connected
7	Not connected
8	Trigger Switch Input
9	Trigger Switch Input

10	Not connected
11	Not connected
12	Not connected

§3.6 Operation environment

- ▲ Height above sea level ≤ 1000 M
- ▲ Operation temperature range $-10 \sim +40$ °C
- ▲ Air relative humidity is below 90 % (20 °C)
- ▲ Preferable site the machine some angles above the floor level, the maximum angle does not exceed 15°C.
- ▲ Protect the machine against heavy rain AND against direct sunshine.
- ▲ The content of dust, acid, corrosive gas in the surrounding air or substance cannot exceed normal standard.
- ▲ Take care that there is sufficient ventilation during welding. There must be at least 30cm free distance between the machine and wall.

§3.7 Operation Notices

- ▲ Read Section §1 carefully before starting to use this equipment.
- ▲ Connect the ground wire with the machine directly.
- ▲ Ensure that the input is three phase: 50/60Hz, 380V $\pm 10\%$.
- ▲ Before operation, none concerned people should not be around the working area and especially children. Do not watch the arc in unprotected eyes.
- ▲ Ensure good ventilation of the machine to improve Duty Cycle.
- ▲ Turn off the engine when the operation finished for energy consumption efficiency.
- ▲ When power switch shuts off protectively because of failure. Don't restart it until problem is resolved. Otherwise, the range of problem will be extended.
- ▲ In case of problems, contact your local dealer if no authorized maintenance staff is available!

§4 Maintenance & Troubleshooting

§4.1 Maintenance

In order to guarantee safe and proper operation of welding machines, they must be maintained regularly. Let customers understand the maintenance procedure of welding machines. Enable customers to carry on simple examination and inspections. Do your best to reduce the fault rate and repair times of welding machines to lengthen service life of arc welding machine. Maintenance items in detail are in the following table.

- **Warning: For safety while maintaining the machine, please shut off the main input power and wait for 5 minutes, until capacitors voltage already drop to safe voltage 36V!**

Date	Maintenance items
------	-------------------

<p>Daily examination</p>	<p>Observe that the knobs and switches in the front and at the back of arc welding machine are flexible and put correctly in place. If any knob has not been put correctly in place, please correct. If you can't correct or fix the knob, please replace immediately;</p> <p>If any switch is not flexible or it can't be put correctly in place, please replace immediately! Please get in touch with maintenance service department if there are no accessories.</p> <p>After turn-on power, watch/listen if the arc-welding machine has shaking, whistle calling or peculiar smell. If there is one of the above problems, find out the reason and clear it. If you can't find out the reason, please contact your local service repair station or distributor/Agent.</p> <p>Observe that the display value of LED is intact. If the display number is not intact, please replace the damaged LED. If it still doesn't work, please maintain or replace the display PCB.</p> <p>Observe that the min./max. Values on LED agree with the set value. If there is any difference and it has affected the normal welding results, please adjust it.</p> <p>Check whether the fan is damaged and whether it is normal to rotate or control. If the fan is damaged, please change immediately. If the fan does not rotate after the machine is overheated, observe if there is something blocking the blade. If it is blocked, please clear the problem. If the fan does not rotate after getting rid of the above problems, you can poke the blade by the rotation direction of fan. If the fan rotates normally, the start capacity should be replaced. If not, change the fan.</p> <p>Observe whether the fast connector is loose or overheated. If the arc-welding machine has the above problems, it should be fastened or changed.</p> <p>Observe whether the current output cable is damaged. If it is damaged, it should be insulated or changed.</p>
<p>Monthly examination</p>	<p>Using the dry compressed air to clear the inside of arc welding machine. Especially for clearing up the dusts on radiator, main voltage transformer, inductors, IGBT modules, fast recover diodes, PCB's, etc.</p> <p>Check the screws and bolts in the machine. If any is loose, please screw it tight. If it is shaved, please replace. If it is rusty, please erase rust on all bolts to ensure it works well.</p>
<p>Quarter- yearly examination</p>	<p>Check whether the actual current accords with the displaying value. If they did not accord, they should be regulated. The actual welding current value can be measured by and adjusted by plier-type ampere meter.</p>
<p>Yearly examination</p>	<p>Measure the insulating impedance among the main circuit, PCB and case, if it below $1M\Omega$, insulation is thought to be damaged and need to change, and need to change or strengthen insulation.</p>

§4.2 Troubleshooting

- Before the welding machines are dispatched from the factory, they have already been

tested and calibrated accurately. **It is forbidden for anyone who is not authorized by our company to do any change to the equipment!**

- Maintenance course must be operated carefully. If any wire becomes flexible or is misplaced, it maybe potential danger to user!
- Only professional maintenance staff that is authorized by our company could overhaul the machine!
- **Be sure to shut off the Main Input Power before doing any repair work on the welding machine!**
- If there is any problem and there is no authorized professional maintenance personal on site, please contact local agent or the distributor!

If there are some simple troubles with the welding machine, you can consult the following Chart:

S/N	Troubles		Reasons	Solution
1	Turn on the power source, and the power lamp is on, but fan doesn't work		There is something in the fan	Clear out
			The start capacitor of fan damaged	Change capacitor
			The fan motor damaged	Change fan
2	The number on the display is not intact.		The LED in the display is broken	Change the LED
3	The max and min value displayed doesn't accord with the set value.		The max value is not accordant	Adjust potentiometer I _{max} on the control board.
			The min value is not accordant	Adjust potentiometer I _{min} the current meter.
4	No no-load voltage output		The machine is damaged	Check the main circuit and the Pr4.
5	Arc can not be ignited (TIG)	There is spark on the HF igniting board.	The welding cable is not connected with the two output of the welder.	Connect the welding cable to the welder's output.
			The welding cable damaged.	Repair or change it.
			The earth cable connected unstably.	Check the earth cable.
			The welding cable is too long.	Use an appropriate welding cable.
			There is oil or dust on the workpiece.	Check and remove it.
			The distance between tungsten electrode and workpiece is too long.	Reduce the distance (about 3mm).
	There is not spark on the HF igniting board.	The HF igniting board does not work.	Repair or change Pr8	
		The distance between the discharger is too short.	Adjust this distance (about 0.7mm).	

S/N	Troubles		Reasons	Solution	
			The malfunction of the welding gun switch.	Check the welding gun switch, control cable and aero socket.	
6	No gas flow (TIG)		Gas cylinder is close or gas pressure is low	Open or change the gas cylinder	
			Something in the valve	Remove it	
			Electromagnetic valve is damaged	Change it	
7	Gas always flows		The gas-test on the front panel is on	The gas-test on the front panel is off	
			Something in the valve	Remove it	
			Electromagnetic valve is damaged	Change it	
			The adjustment knob of pre-gas time on the front panel is damaged	Repair or change it	
8	The welding current can not be adjusted		The welding current potentiometer on the front panel connection is not good or damaged	Repair or change the potentiometer	
9	The welding current displayed isn't accordant with the actual value.		The min value displayed isn't accordant with the actual value.	Adjust potentiometer Imin on the power board.	
			The max value displayed isn't accordant with the actual value.	Adjust potentiometer Imax on the power board.	
10	The penetration of molten pool is not enough.		The welding current is adjusted too low	Increase the welding current	
11	The alarm lamp on the front panel is on		Over heat protection	Two much welding current	Reduce the welding current output
				Working time too long	Reduce the duty cycle (work intermittently)

§4.3 List of error code

Error Type	Error code	Description	Lamp status
Thermal relay	E01	Over-heating(1st thermal relay)	Yellow lamp(thermal protection) always on
	E02	Over-heating(2nd thermal relay)	Yellow lamp(thermal protection) always on
	E03	Over-heating(3rd thermal relay)	Yellow lamp(thermal protection) always on
	E04	Over-heating(4th thermal relay)	Yellow lamp(thermal protection) always on
	E09	Over-heating(Program in default)	Yellow lamp(thermal protection) always on
Welding machine	E10	Phase loss	Yellow lamp(thermal protection) always on
	E11	No water	Yellow lamp(lack water) always on
	E12	No gas	Red lamp always on

	E13	Under voltage	Yellow lamp(thermal protection) always on
	E14	Over voltage	Yellow lamp(thermal protection) always on
	E15	Over current	Yellow lamp(thermal protection) always on
	E16	Wire feeder over load	
Switch	E20	Button fault on operating panel when switch on the machine	Yellow lamp(thermal protection) always on
	E21	Other faults on operating panel when switch on the machine	Yellow lamp(thermal protection) always on
	E22	Torch fault when switch on the machine	Yellow lamp(thermal protection) always on
	E23	Torch fault during normal working process	Yellow lamp(thermal protection) always on
Accessory	E30	Cutting torch disconnection	Red lamp blink
	E31	Water cooler disconnection	Yellow lamp(lack water) always on
Communication	E40	Connection problem between wire feeder and power source	
	E41	Communication error	

§4.4 Electrical schematic drawing

