

PLEASE TAKE ONE

AUGUST 2023



# 2023 PRODUCT CATALOGUE



[WWW.TOPGUNWELDING.COM.AU](http://WWW.TOPGUNWELDING.COM.AU)





## TOP GUN WELDING SUPPLIES PTY LTD.

### THEN

Established in the early 2000's, Top Gun Welding Supplies saw an opening in the market for high quality welding torch consumables at competitive prices. With the increasing demand for supply, the decision was made to extend the range into TIG welding and Plasma consumables. As we created a strong customer base with our reliable products, feedback from end-users saw us shift our sights to advancements in welding technology.

With the introduction of inverter welding machines, plasma cutters and safety apparel, the Top Gun name established its place in the market as a trusted brand with competitive pricing. Our range meets the needs of industrial, home workshop, education, training and rural settings.

### NOW

Our mission remains the same as it always has: To provide the latest welding technology and high quality products at affordable prices. Staying up to date with welding advancements allows us to continually develop the Top Gun range.

We maintain a large network of agents throughout Australia to provide fast supply and product support no matter where located.





## **CONTENTS**

**WELDING MACHINES**

**4**

**PLASMA CUTTERS**

**9**

**GAS & STRAIGHT LINE CUTTERS**

**10**

**HELMETS**

**11**

**MIG HAND PIECES AND CONSUMABLES**

**13**

**MIG DRIVE ROLLER GUIDE**

**19**

**WELDING ACCESSORIES**

**20**

**WIRE AND ELECTRODES**

**23**

**TIG HAND PIECES AND CONSUMABLES**

**25**

**PLASMA TORCHES AND CONSUMABLES**

**30**

**GAS EQUIPMENT**

**33**

**ABRASIVES & SAFETY EQUIPMENT**

**36**

**AUTOMATION**

**38**



## WELDING MACHINERY

### Top Gun 144 Micro

PN. TGWARC144M **VRD**

The Top Gun Arc 144 Micro is an ultra portable 140A MMA stick welding machine for smaller welding tasks. Supplied with a sturdy carry case, and adjustable shoulder strap, this machine can be used any where, any time.



Input Voltage (V)	240 A/C	Rated Duty Cycle	15% @ 140A	Weight	3kg
Frequency (Hz)	50/60 Hz		60% @ 92A	Dimensions	220x90x140
Output Current Range (A)	40-140 A		100% @ 50A	Warranty	3 Years

Standard Accessories:

Users Manual, 1.5 MTR Tong Type Electrode Holder Lead, 1.5 MTR Earth Lead, 10A plug, Sturdy Carry Case.

### Top Gun I-ARC-145 & I-ARC-200

PN. TGWARC145 / TGWARC200 **VRD**

The Top Gun Arc 145 and Arc 200 are the portable stick welders for smaller welding tasks. Great for hobbyists and trades people alike, offering the operator the benefits of inverter welder technology at an affordable price.



	ARC 145	ARC 200
Input Voltage (V)	240 A/C	240 A/C
Frequency (Hz)	50/60 Hz	50/60 Hz
Output Current Range (A)	10-140 A	10-200 A
Rated Duty Cycle	25% @ 140A 60% @ 70A 100% @ 55A	25% @ 200A 60% @ 130A 100% @ 100A
Weight	3.5 kg	
Dimensions	320x135x250	
Warranty	3 Years	

Standard Accessories:

Users Manual, 4 MTR Twist Lock Electrode Holder Lead, 4 MTR Earth Lead, VRD with front panel LED indicator, Small Top Gun Carry Bag. 145 is fitted with 10A plug, 200 is fitted with 15A plug.

### Top Gun MIG 165 MST

PN. TGWMIG165MST **SYNERGIC**

The Top Gun Mig 165 MST is a light to medium duty inverter welder, capable of multiple processes such as Mig, Stick (MMA) & DC TIG. With Synergic capabilities, this portable, single phase machine is best suited to panel work, general maintenance, fabrication and workshop usage.

Input Voltage (V)	240 A/C	Rated Duty Cycle	15% @ 165A	Weight	9kg
Frequency (Hz)	50/60 Hz		60% @ 83A	Dimensions	410x165x300
Output Current Range (A)	40-165 A		100% @ 64A	Warranty	3 Years

Standard Accessories:

Users Manual, MB15 3 MTR Handpiece, 3 MTR Earth Lead, 3 MTR Tong Type Electrode Holder, 3 MTR Gas Hose with Quick Connect Fittings, 0.8 - 1.0mm Solid Roller, 1.0 - 1.2mm Flux Cored Roller, Fitted 1 Phase 10A Plug.



### Top Gun MIG 182

PN. TGWMIG182 **SPOOL GUN READY**

The Top Gun Mig 182 is a light to medium duty inverter welder, capable of multiple processes such as Mig, DC Tig, Stick (MMA.) This light weight, single phase machine is best suited to panel work, general maintenance, fabrication and workshop usage.

Input Voltage (V)	240 A/C	Rated Duty Cycle	10% @ 180A	Weight	11kg
Frequency (Hz)	50/60 Hz		60% @ 73A	Dimensions	510x280x350
Output Current Range (A)	40-180 A		100% @ 57A	Warranty	3 Years

Standard Accessories:

Users Manual, MB15 3 MTR Handpiece, 3 MTR Earth Lead, 3 MTR Twist Lock Electrode Holder, 2 MTR Gas Hose with Quick Connect Fittings, 0.6 - 0.8mm "V" Steel Roller, 0.9 - 1.2mm "V" Steel Roller, 0.8 - 0.9mm "F" Knurled Roller, 1.0 - 1.2mm "U" Aluminium Roller, Fitted 1 Phase 10A Plug



## Top Gun MIG 206 MS

PN. TGWMIG206MS **SPOOL GUN READY**

The Top Gun Mig 206 MS is a light to medium duty inverter welder, capable of multiple processes such as Mig and Stick (MMA.) This portable, single phase machine is best suited to panel work, general maintenance, fabrication and workshop usage.



Input Voltage (V)	240 A/C	Rated Duty Cycle	25% @ 200A	Weight	12kg
Frequency (Hz)	50/60 Hz		60% @ 155A	Dimensions	510x280x350
Output Current Range (A)	40-200 A		100% @ 120A	Warranty	3 Years

Standard Accessories:

Users Manual, MB24 4 MTR Handpiece, 4 MTR Earth Lead, 4 MTR Twist Lock Electrode Holder, 2 MTR Gas Hose with Quick Connect Fittings, 0.6 - 0.8mm Solid Roller, 0.9 - 1.2mm Solid Roller, 0.8 - 0.9mm "F" Knurled Roller, 1.0 - 1.2mm Aluminium Roller, Twin Gauge Regulator, Fitted 1 Phase 15A Plug

## Top Gun 210L

PN. TGWMIG210L **VRD** **SYNERGIC** **SPOOL GUN READY**

The Top Gun 210L is a single phase powerhouse with the functions needed for light to medium duty tasks. With an excellent duty cycle, multi process capabilities, Power Factor Correction, and an LCD display with optional preset function settings, these portable inverter welders make any welding task an easy one.



Input Voltage (V)	240 A/C	Rated Duty Cycle	60% @ 142A	Weight	13.5kg
Frequency (Hz)	50/60 Hz		100% @ 110A	Dimensions	460x215x375
Output Current Range (A)	40-200 A			Warranty	3 Years

Standard Accessories:

Users Manual, 2 Roller Wire Feeder, 3 MTR MB24 Euro-Fit Mig Torch, 2 MTR Earth Lead, MB24 Consumable Starter Kit, Fitted 15A Plug, Twin Gauge Regulator, 3 MTR Gas Hose with Quick Connect Fitting, 0.8mm - 0.9mm "V" Steel Rollers, 0.9mm - 1.2mm "F" Knurled Rollers.

## Top Gun 200 4-in-1

PN. TGWMIG2004IN1 **VRD** **SYNERGIC** **SPOOL GUN READY**

The Top Gun 200 4-in-1 is a combination Mig, AC/DC Pulse Tig, and Stick Welder machine. With Synergic functions for all welding processes, this compact unit gives the operator complete control for any application.

Input Voltage (V)	240 A/C	Rated Duty Cycle	25% @ 200A	Weight	15 kg
Frequency (Hz)	50/60 Hz		60% @ 130A	Dimensions	660x210x330
Output Current Range (A)	40-200 A		100% @ 100A	Warranty	3 Years

Standard Accessories:

Users Manual, 4 MTR MB24 Euro-Fit Mig Torch, 4 MTR Tig 26 Torch with Thumbwheel Control, 4 MTR Earth Lead with Clamp, 4 MTR Electrode Lead with Twist Type Electrode Holder, 0.8 - 0.9mm "V" Solid Roller, 1.0 - 1.2mm "V" Solid Roller, 0.8 - 0.9mm "F" Knurled Roller, 1.0 - 1.2mm "F" Knurled Roller, 0.8 - 0.9mm "U" Aluminium Roller, 1.0 - 1.2mm "U" Aluminium Roller, Quick Coupler For Gas Outlet on Front Panel, Quick Connect Gas Connection, 2 MTR PVC Gas Hose



## Top Gun 2004L Synergic Pulse Mig

PN. TGWMIG2004L **VRD** **SYNERGIC** **SPOOL GUN READY**

With the new 2004L Synergic Dual pulse Synergic MIG, operators are given the ability to select which setting best suits their application, resulting in a perfect bead three times faster than TIG welding.

Input Voltage (V)	240 A/C	Rated Duty Cycle	60% @ 200A	Weight	13.5kg
Frequency (Hz)	50/60 Hz		100% @ 155A	Dimensions	460x215x375
Output Current Range (A)	40-200 A			Warranty	3 Years

Standard Accessories:

Users Manual, 4 Roller Wire Feeder, 3 MTR MB24 Euro-Fit Mig Torch, 4 MTR Earth Lead, 2 MTR Tong Type Electrode Holder Lead, 0.8mm - 0.9mm "V" Steel Rollers, 0.8mm - 0.9mm "U" Aluminium rollers, 1.0mm - 1.2mm "U" Aluminium rollers, 0.8mm - 0.9mm "K" Flux-cored rollers, 1.0mm - 1.2mm "K" Flux-cored rollers, Fitted Single Phase 15A Plug, MB24 Consumable Starter Kit, Twin Gauge Regulator, Gas Hose 3 MTR with Quick Connect Fitting



4 ROLLER  
WIRE FEED

## Top Gun 255 LCD PFC

PN. TGWMIG255PFCLCD **VRD** **SYNERGIC** **SPOOL GUN READY**

The Top Gun TITAN 255 PFC LCD is our most powerful single phase machine with all the functions an operator could need for light to medium duty tasks. With a heavy duty cycle, multi process capabilities, Power Factor Correction, and an LCD display with optional preset function settings, these portable inverter welders make any welding task an easy one.

Input Voltage (V)	240 A/C	Rated Duty Cycle	35% @ 250A	Weight	25.5kg
Frequency (Hz)	50/60 Hz		100% @ 150A	Dimensions	630x240x445
Output Current Range (A)	40-250 A			Warranty	3 Years

Standard Accessories:

Users Manual, 4 Roller Wire Feeder, 4 MTR MB24 Euro-Fit Mig Torch, 4 MTR Earth Lead with Topgun 600A Clamp, 4 MTR Twist Lock Electrode Holder Lead, 0.8mm - 0.9mm "V" Steel Roller, 0.8mm - 1.2mm "F" Knurled Roller, 1.0mm - 1.2mm "U" Aluminium rollers, Quick Connect for Tig Torch, Fitted Single Phase 15A Plug, MB24 Consumable Kit, Twin Gauge Regulator, Gas Hose 2 MTR with Quick Connect Fitting



## Top Gun 2500 SYN Dual Pulse Mig

PN. TGWMIG2500L **VRD** **SYNERGIC** **SPOOL GUN READY**

With the new 2500 SYN Dual pulse Synergic MIG, operators have the opportunity to select which process and function best suits their application, resulting in perfect beading three times faster than TIG welding.



Input Voltage (V)	240 A/C	Rated Duty Cycle	30% @ 250A	Weight	31.5kg
Frequency (Hz)	50/60 Hz		60% @ 177A	Dimensions	600x500x270
Output Current Range (A)	40-250 A		100% @ 137A	Warranty	3 Years

### Standard Accessories:

Users Manual, 4 Roller Wire Feeder, 4 MTR MB24 Euro-Fit Mig Torch, 4 MTR Earth Lead, 2 MTR Tong Type Electrode Holder Lead, 0.8mm - 0.9mm "V" Steel Roller, 1.0mm - 1.2mm "U" Aluminium rollers, Fitted Single Phase 15A Plug, MB24 Consumable Starter Kit, Twin Gauge Regulator, Gas Hose 3 MTR with Quick Connect Fitting



## Top Gun 2040 5-in-1

PN. TGWMIG2040L5IN1 **VRD** **SYNERGIC** **SPOOL GUN READY**

The Top Gun 2040 5-in-1 is a combination Dual Pulse Mig, AC/DC Tig, Stick Welder and Plasma Cutting machine. With Synergic functions for all welding processes, and up to 40A plasma cutting capabilities, this single phased machine is the perfect unit for any project.

### General Specifications

Input Voltage (V)	240 A/C
Frequency (Hz)	50/60 Hz
Weight	26 kg
Dimensions	750x250x470
Warranty	3 Years

### AC/DC TIG Specifications

Output Current Range (A)	10-200 A
Rated Duty Cycle	40% @ 200A
	60% @ 163A
	100% @ 127A

### MIG Specifications

Output Current Range (A)	40-200 A
Rated Duty Cycle	40% @ 200A
	60% @ 163A
	100% @ 127A

### Plasma Specifications

Output Current Range (A)	20-40 A
Rated Duty Cycle	40% @ 40A
	60% @ 33A
	100% @ 25A
Cutting Thickness	Rec. 16mm
	Sev. 20mm
Air Flow	30-100 L-min

### Standard Accessories:

Users Manual, MB24 3 MTR Handpiece, 4 MTR Tig 26 Torch with Thumb wheel Control, 6 MTR PT60 Plasma Torch with Euro Central Adaptor, 3 MTR Earth Lead with 600A Clamp, 3 MTR Electrode Lead with Tong Type Electrode Holder, Quick Coupler for Gas Outlet on Front Panel, Quick Connect Gas Connection, 2 MTR PVC Gas Hos, 0.8mm - 0.9mm "V" Steel Roller Set, 0.8mm - 0.9mm "F" Knurled Roller set, Twin Gauge Regulator, Fitted Single Phase 15A Plug.

## Top Gun TITAN 2500 SYN SWF / 3500 SYN SWF

PN. TGWMIG2500LSWF, TGWMIG3500LSWF **VRD** **SYNERGIC**

With the new Top Gun 2500 SYN SWF Dual Pulse and 3500 SYN SWF Dual pulse Synergic MIG Welders, operators have the opportunity to select which process and function best suits their application, resulting in perfect beading three times faster than TIG welding.

	MIG 2500 SYN SWF	MIG 3500 SYN SWF
Input Voltage (V)	240 A/C	415 A/C
Frequency (Hz)	50/60 Hz	50/60 Hz
Output Current Range (A)	40-250 A	40-350 A
Rated Duty Cycle	40% @ 250A	40% @ 350A
	60% @ 204A	
	100% @ 158A	100% @ 221A
Weight	64kg	
Dimensions	820 x 510 x 800	
Warranty	3 Years	



### Standard Accessories:

Users Manual, 10 MTR Interconnecting Leads, 4 Roller Wire Feeder, 4 MTR MB36 Euro-Fit Mig Torch, MB 36 Consumable Starter Kit, 10 MTR Earth Lead, 0.8mm - 0.9mm "V" Steel Rollers, 1.0mm - 1.2mm "V" Steel Rollers, 0.8mm - 0.9mm "U" Aluminium Rollers, 1.0mm - 1.2mm "U" Aluminium Rollers, 0.9mm - 1.2mm "F" Knurled Rollers, Twin Gauge Argon Regulator. 2500 SYN is fitted with 15A plug. 3500 SYN is fitted with 3 phase 4 pin (20A or 32A) plug.



## Top Gun 355F & 515F

PN. TGWMIG355F, TGWMIG515F **VRD** **SPOOL GUN READY**

The Top Gun 355F & 515F are the largest machines in the Top Gun Range. 3 Phase power supply allows for a heavy duty cycle, and the separate wire feeder and trolley mean you can take that power anywhere. With Mig, Stick, DC Tig, Spool gun, Push-Pull and Gouging\* capabilities, these machines will keep up with the high demand of the busiest workshops. \*Gouging only available using 515F power source.



	MIG 355F	MIG 515F
Input Voltage (V)	415 A/C	415 A/C
Frequency (Hz)	50/60 Hz	50/60 Hz
Output Current Range (A)	40-350 A	40-500 A
Rated Duty Cycle	60% @ 350A 100% @ 275A	60% @ 500A 100% @ 400A
Weight	80kg	
Dimensions	1040x1450x510	
Warranty	3 Years	

### Standard Accessories:

Users Manual, 10 MTR Interconnecting Leads, Separate Wire Feeder, 4 MTR MB36 Euro-Fit Mig Torch, 8 MTR Earth Lead with Top gun 600A Clamp, 8 MTR Electrode Holder Lead Twist Lock, 0.8mm - 0.9 mm "V" Steel Rollers, 1.2mm - 1.6mm "V" Steel Rollers, 0.9mm - 1.2mm "F" Knurled Rollers, 1.2mm - 1.6mm "F" Knurled Rollers, Welding Trolley with Storage Drawer, Quick Connect Fittings for Tig Torch and Gas Hose, Twin Gauge Regulator, MB 36 Consumable Kit, Gas Hose 2MTR with Quick Connect Fitting, fitted with 3 phase 4 pin (20A or 32A) plug.

## Top Gun 3500 SYN Dual Pulse Mig

PN. TGWMIG3500L **VRD** **SYNERGIC** **SPOOL GUN READY**

For larger projects, the new 3500 SYN Dual pulse Synergic MIG, operators have the choice to select which process and function best suits their application, resulting in impeccable beading three times faster than TIG welding.

Input Voltage (V)	415 A/C	Rated Duty Cycle	60% @ 248A	Weight	44.2kg
Frequency (Hz)	50/60 Hz		100% @ 192A	Dimensions	820x510x800
Output Current Range (A)	40-350 A			Warranty	3 Years

### Standard Accessories:

Users Manual, 4 Roller Wire Feeder, 4 MTR MB36 Euro-Fit Mig Torch, 4 MTR Earth Lead, 2 MTR Tong Type Electrode Holder Lead, 0.8mm - 0.9mm "V" Steel Roller, 1.0mm - 1.2mm "U" Aluminium rollers, MB36 Consumable Starter Kit, Twin Gauge Regulator, Gas Hose 3 MTR with Quick Connect Fitting. Fitted with 3 phase 4 pin (20A or 32A) plug.



## Top Gun TITAN 5000 SYN SWF / 5000 SYN SWF Water-cooled

PN. TGWMIG5000LSWF, TGWMIG5000LSWFC **VRD** **SYNERGIC**

With the new Top Gun 5000 SYN SWF Dual Pulse Synergic MIG, operators have the choice to select which process and function best suits their application, resulting in perfect beading three times faster than TIG welding. With a water cooled option, these machines can keep up with the high demand of the busiest workshops, and are perfect for heavy industrial welding processes.



	MIG 5000 SYN SWF	MIG 5000 SYN SWF WC
Input Voltage (V)	415 A/C	415 A/C
Frequency (Hz)	50/60 Hz	50/60 Hz
Output Current Range (A)	40-500 A	40-500 A
Rated Duty Cycle	40% @ 500A 100% @ 316A	40% @ 500A 100% @ 316A
Weight	64kg	
Dimensions	820 x 510 x 800	
Warranty	3 Years	

### Standard Accessories:

Users Manual, 10 MTR Interconnecting Leads, 4 Roller Wire Feeder, 4 MTR MB36 Euro-Fit Mig Torch, MB 36 Consumable Starter Kit, 10 MTR Earth Lead, 0.8mm - 0.9mm "V" Steel Rollers, 1.0mm - 1.2mm "V" Steel Rollers, 0.8mm - 0.9mm "U" Aluminium Rollers, 1.0mm - 1.2mm "U" Aluminium Rollers, 0.9mm - 1.2mm "F" Knurled Rollers, Twin Gauge Argon Regulator. Fitted with 3 phase 4 pin (20A or 32A) plug.

## Top Gun 195 DC Pulse Tig

PN. TGWTIG195DC **VRD** **SYNERGIC**

The Top Gun Warrior 195 DC Pulse Tig is a light to medium duty inverter welder, capable of DC Pulse Tig (GTAW), and Stick (MMA). This ultra portable, single phase machine is best suited to panel work, general maintenance, fabrication and workshop usage.

Input Voltage (V)	240 A/C	Rated Duty Cycle	30% @ 200A	Weight	11.5kg
Frequency (Hz)	50/60 Hz		60% @ 142A	Dimensions	375x160x310
Output Current Range (A)	10-200 A		100% @ 110A	Warranty	3 Years

Standard Accessories:

Users Manual, 4 MTR Tig 26 Hand Piece with Thumb Wheel Control, 4 MTR Electrode Lead with Tong Type Electrode Holder, 4 MTR Earth Lead Holder, 3 MTR Gas Hose with Quick Connect Fittings, 3M 5mm PVC Gas Hose, Argon Bobbin Regulator, Fitted 1 Phase 15A Plug



## Top Gun 215E AC/DC Pulse

PN. TGWTIG215EACDC

The 215E AC/DC tig is FEATURE PACKED, With Pulse, HF start, AC, DC and Stick capabilities, lightweight and compact design the TOP GUN 215E has all the functionality you will ever need. Perfect for the workshop, home or on-site and comes complete with everything needed to get started.

Input Voltage (V)	240 A/C	Rated Duty Cycle	30% @ 200A	Weight	7kg
Frequency (Hz)	50/60 Hz		60% @ 155A	Dimensions	480x450x310
Output Current Range (A)	10-200 A		100% @ 120A	Warranty	3 Years

Standard Accessories:

Users Manual, 4 MTR Tig 26 Hand Piece with Thumb Wheel Control, 4 MTR Twist Lock Electrode Holder Lead, 4 MTR Earth Lead, Quick Connect Coupler for Gas Outlet, 2 MTR 5mm PVC Gas Hose, Fitted 15A plug



## Top Gun 2000 AC/DC Pulse Tig

PN. TGWTIG2000ACDC **VRD** **SYNERGIC**

The new 2000 series AC/DC Pulse tig brings users the ability to select which process and function best suits their TIG application. With Synergic operation capabilities, this tig does the thinking for you, allowing you to set your parameters and get straight to welding perfect beads.

Input Voltage (V)	240 A/C	Rated Duty Cycle	30% @ 200A	Weight	15.1kg
Frequency (Hz)	50/60 Hz		60% @ 163A	Dimensions	460x215x375
Output Current Range (A)	10-200 A		100% @ 126A	Warranty	3 Years

Standard Accessories:

Users Manual, 4 MTR Tig 26 Hand Piece with Thumb Wheel Control, 2 MTR Tong Type Electrode Holder Lead, 4 MTR Earth Lead, Quick Connect Coupler for Gas Outlet, 3M 5mm PVC Gas Hose, Argon Bobbin Regulator, Fitted 15A Plug



## Top Gun 3200 AC/DC

PN. TGWTIG3200ACDC **VRD** **SYNERGIC**

The Top Gun 3200 AC/DC is a three phase water cooled AC/DC TIG/STICK welding machine with high frequency capabilities allowing for optimum performance and premium welds. Packed full of features including a high duty cycle, easy to operate LCD screen display, adjustable and preset weld sequence controls and adjustable pulse.

Input Voltage (V)	415 A/C	Rated Duty Cycle	40% @ 320A	Weight	53.8kg
Frequency (Hz)	50/60 Hz		60% @ 261A	Dimensions	810x510x800
Output Current Range (A)	10-320 A		100% @ 202A	Warranty	3 Years

Standard Accessories:

Users Manual, 8 MTR Tig 18 Torch with Thumb Wheel Control, 5 MTR Earth Clamp Lead, Internal Water Cooler, Bobbin Regulator, 3 MTR Quick Connect Gas Hose with Fittings. Fitted with 3 phase 4 pin (20A or 32A) plug.



## Top Gun 325 AC/DC

PN. TGWTIG325ACDC **VRD**

The Top Gun 325 AC/DC is a three phase water cooled AC/DC TIG/STICK welding machine with high frequency capabilities allowing for optimum performance and premium welds. Packed full of features including a high duty cycle, easy to operate LED display, adjustable and preset weld sequence controls and adjustable pulse. Water cooler, trolley and foot control all included.

Input Voltage (V)	415 A/C	Rated Duty Cycle		Weight	92kg
Frequency (Hz)	50/60 Hz		60% @ 320A	Dimensions	550x240x445
Output Current Range (A)	10-320 A		100% @ 250A	Warranty	3 Years

Standard Accessories:

Users Manual, 8 MTR Tig 18 Torch with Thumb Wheel Control, 8 MTR Earth Lead with Top Gun 600A Clamp, 8 MTR Twist Lock Electrode Lead, 5 MTR Lead with Foot Control, Welding Trolley, Water Cooler, Bobbin Regulator, 2 MTR Quick Connect Gas Hose with Fittings. Fitted with 3 phase 4 pin (20A or 32A) plug.





# PLASMA CUTTERS

## TOPGUN Cut 42 PFC

PN. TGWPCUT42PFC

With an excellent 25mm Severance cut, and a clean cut of up to 20mm, the Top Gun Cut 42 PFC is a single phase powerhouse, perfect for all metal cutting applications. Featuring Power Factor Correction functionality, the cut 42 PFC is able to maintain power efficiency with varying line input voltage, ensuring consistent and efficient cutting performance.

Severance:	25mm	Input Voltage:	240V
Rated Duty Cycle (%):	60% @ 36A	Input Current Range:	35A
	100% @ 30A	Output Current Range:	40A
Gas Flow:	30-100 L/min	Adjustable Current Range:	20 - 40A CUT
Net Weight:	8 Kg	Cutting Thickness:	8 - 20mm

Fitted 1 Phase 15A Plug



## TOPGUN Cut 65 CNC

PN. TGWPCUT65CNC

The Top Gun Cut 65 CNC was designed to be the perfect companion to any CNC plasma cutting table. With clean cutting capabilities of up to 25mm, and a 35mm severance cut, these 3 phase plasma machines are the ideal choice for both hand and automated plasma cutting.

Input Voltage:	415V	Severance:	35mm
Input Current Range:	18A	Rated Duty Cycle (%):	90% @ 65A
Output Current Range:	65A		100% @ 61A
Adjustable Current Range:	20 - 65A CUT	Gas Flow:	30-100 L/min
Cutting Thickness:	8 - 25mm	Net Weight:	24 Kg

Fitted with 3 phase 4 pin (20A or 32A) plug.



## TOPGUN Cut 120 CNC

PN. TGWPCUT120CNC

The Top Gun Spitfire Cut 120 CNC is a heavy duty 3 phase plasma cutter manufactured for the largest of CNC plasma cutting processes. Clean cutting at up to 50mm, and a severance cut of 70mm, these machines are perfect for the heavy fabrication industry and large scale workloads.

Input Voltage:	415V	Severance:	70mm
Input Current Range:	36A	Rated Duty Cycle (%):	60% @ 120A
Output Current Range:	120A		100% @ 95A
Adjustable Current Range:	20 - 120A CUT	Gas Flow:	30-100 L/min
Cutting Thickness:	12 - 50mm	Net Weight:	33 Kg

Fitted with 3 phase 4 pin (20A or 32A) plug.



# GAS & STRAIGHT LINE CUTTERS

## TOP GUN Bob-cat Beetle

The Top Gun Bob Cat Beetle Straight Line Cutter is an easy to operate oxy/fuel automated welding carriage designed to produce high quality cuts, circles and bevels with high precision. Available in both single and twin torch packages, this high quality, low cost alternative comes with everything required for high accuracy gas cutting.

<b>Cutting Thickness</b>	5-50mm (by standard accessories)	<b>Motor</b>	Condensor-Induction
<b>Cutting Speed</b>	150 - 800mm/min	<b>Power source</b>	220V-50Hz
<b>Speed Control</b>	Single Cone System	<b>Warranty</b>	2 Years



### Single Torch Package Includes

- Topgun Straight Line Cutting Machine
- Torch Holder with Rack
- Torch
- Gas Distributor
- Gas Hose, 600mm
- 1.8 Metre solid Steel Track
- Flint Lighter
- Tip Cleaner
- 1/32" (0.8mm) Cutting Nozzle    3/64" (1.2mm) Cutting Nozzle    1/16" (1.6mm) Cutting Nozzle

### Ordering Information

Topgun Straight Line Cutting Machine Single TGGSLC



### Twin Package Includes

- Topgun Straight Line Cutting Machine
- Torch Holder with Rack x 2
- Torch x 2
- Gas Distributor X 2
- Gas Hose, 600mm x 2 & 900mm x 2
- 1.8 Metre solid Steel Track
- Flint Lighter
- Tip Cleaner
- 1/32" (0.8mm) Cutting Nozzle x 2    3/64" (1.2mm) Cutting Nozzle x 2    1/16" (1.6mm) Cutting Nozzle x 2

### Ordering Information

Topgun Straight Line Cutting Machine Double TGGSLCD

## TOP GUN Pipe Cutter

The Top Gun pipe cutter is a compact pipe cutter developed on the basis of the actual conditions of installed pipelines and work sites where pipe cutting is needed. The machine will exhibit excellent performance in straight and bevel cutting of all sizes of pipes, which accounts for most of pipe cutting work, being habitually used by many users.



### Package Includes

- Topgun Pipe Cutting Machine
- Torch Holder with Rack
- Torch
- Gas Distributor
- Gas Hose Set
- Chain (80 pcs)
- Flint Lighter
- Tip Cleaner
- No.1 Cutting Nozzle
- No.2 Cutting Nozzle
- No.3 Cutting Nozzle

### Ordering Information

Topgun Pipe Cutting Machine STSG30



# AUTO DARKENING WELDING HELMETS



## SERIES

The new Top Gun Warrior Series auto-darkening welding helmet range offers dual independent arc sensors for a 1/30000s lens darkening reaction time with adjustable sensitivity for exceptional UV protection.

With inter-changeable lithium batteries and a solar cell assist, the electronic lens in this light-weight helmet is long lasting and ready to work when you are.



TGHWARBLUINF

TGHWARCFIBRE

WARRIOR SERIES	Part no. TGHWAR...
Optical Class:	1/1/1/2
Viewing Area:	96mm x 39mm
Dark State:	DIN4, 9-13 stepless variable
Switching Time:	1/30,000s from light to dark
Grinding Mode:	Yes
Warranty:	2 Years
Weight:	500g



TGHWARINFERNO

TGHWARGBLCK

Description	Part Number
Warrior Helmet Inner Lens - 102mm x 42mm PKT5	TGHLWI
Warrior Helmet Outer Lens - 103mm x 115mm PKT5	TGHLWO

## TITAN SERIES



TGHTSHAD



TGHTSPIDER

TGHTSTEEL

TGHTENVI

TGHTROBO

TGHTCCARB

TGHTBION

TGHTRICH



The Top Gun TITAN series auto-darkening welding helmet range offers one of the largest viewing areas on the market. The huge 98mm x 87mm electronic lens allows the user to have a larger, clearer view of the job at hand. With four sensors, solar cell assist, interchangeable batteries, and a 1/30000s switching time, the Top Gun Titan Series auto-darkening welding helmet is the right choice for optimal UV protection.

Description	Part Number
Titan Helmet Inner Lens - 110mm x 92mm PKT5	TGHLTI
Titan Helmet Outer Lens - 137mm x 118mm PKT5	TGHLTO

TITAN SERIES	Part no. TGHT...
Optical Class:	1/1/1/2
Viewing Area:	98mm x 87mm
Dark State:	DIN4/5-8/9-13 stepless variable
Switching Time:	1-30,000s from light to dark
Grinding Mode:	Yes
Warranty:	2 Years
Weight:	500g

# AUTO DARKENING WELDING HELMETS

## TITAN SERIES PANORAMIC

The new Top Gun TITAN PANORAMIC series auto-darkening welding helmet range offers an even wider extended viewing area with the addition of two auto darkening side windows.

TITAN PANORAMIC	
Optical Classification	1/1/1/1
Viewing Area	Main Window: 100mm x 67mm Side Windows: 32/70mm x 65mm
Arc Sensor	6
Dark State	Main Window: 5-9/9-13 Side Window: 11
Switching Time	1/30.000s
Grind Mode	Internal
Warranty	2 Years
Weight	650g

Description	Part Number
Titan Panoramic Helmet Inner Lens Set 3PK	TGHLTPI
Titan Panoramic Helmet Outer Lens EA	TGHLTPO



### TOP GUN TITAN FLIP STEALTH

The new Top Gun TITAN Flip Stealth auto-darkening welding helmet offers flip up functionality with a large curved grinding visor, as well as additional fixed shade 5 side windows for optimum peripheral vision.

TITAN SERIES	Part no. TGHTFLIPS
Optical Class:	1/1/1/2
Viewing Area:	108mm x 82mm
Dark State:	DIN3/4-8/9-13 Digital Display
Switching Time:	1-30,000s from light to dark
Grinding Mode:	Yes
Power Supply:	Solar Cell 2 x CR2450 Lithium Batteries
Warranty:	2 Years
Weight:	500g

Description	Part Number
Titan Flip Stealth Helmet Inner Lens PKT5	TGHTLFI
Titan Flip Stealth Helmet Outer Lens PKT5	TGHTLFO
Titan Flip Stealth Helmet Grinding Lens EA	TGHTLFG



### Assorted Helmet Spares

Description	Part Number	Description	Part Number
Top Gun Adjustable Head Harness	TGTHH	Top Gun Titan Lens Frame	TGHTFRAME
Top Gun Warrior Auto Darkening Lens Replacement	TGHWAUTO	Top Gun Titan Flip Auto Darkening Lens Replacement	TGHTAUTOFLIP
Top Gun Warrior Lens Frame	TGHWFRAME	Top Gun Helmet Replacement Clip Assembly	TGHCLIPS
Top Gun Titan Auto Darkening Lens Replacement	TGHTAUTO	Top Gun CR2450 Helmet Battery	TGHBAT



# MIG TORCHES



Binzel Style MB15	Part No.
Topgun MB15 3 Metre "Binzel Style" Mig Torch Euro Connection	TGTMB1503
Topgun MB15 4 Metre "Binzel Style" Mig Torch Euro Connection	TGTMB1504
Topgun MB15 5 Metre "Binzel Style" Mig Torch Euro Connection	TGTMB1505



Binzel Style MB24	Part No.
Topgun MB24 3 Metre "Binzel Style" Mig Torch Euro Connection	TGTMB2403
Topgun MB24 4 Metre "Binzel Style" Mig Torch Euro Connection	TGTMB2404
Topgun MB24 5 Metre "Binzel Style" Mig Torch Euro Connection	TGTMB2405



Binzel Style MB36	Part No.
Topgun MB36 3 Metre "Binzel Style" Mig Torch Euro Connection	TGTMB3603
Topgun MB36 4 Metre "Binzel Style" Mig Torch Euro Connection	TGTMB3604
Topgun MB36 5 Metre "Binzel Style" Mig Torch Euro Connection	TGTMB3605



Bernard Style 300A	Part No.
Topgun 300A "Bernard Style" Mig Torch 3.5 Metre	TGTBE30035
Topgun 300A "Bernard Style" Mig Torch 4.6 Metre	TGTBE30046



Tweco #4 Style	Part No.
Topgun TW4 "Tweco Style" 3.5 Metre Mig Torch Euro Connection	TGTTW4035
Topgun TW4 "Tweco Style" 4.6 Metre Mig Torch Euro Connection	TGTTW4046



Lincoln K126 Style	Part No.
Topgun K126 Squirt Gun "Lincoln Style" 4.6 Metre Mig Torch	Lincoln Fit TGTLIK12611
	Tweco Fit TGTLIK12612
	Euro Fit TGTLIK12613

# BINZEL STYLE MIG CONSUMABLES

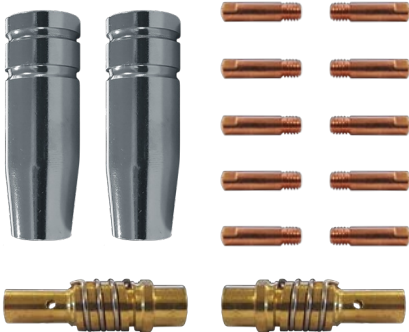

**MB15 Consumable Kits TGKIT15**

- 5 x TT100102 0.8mm Tips
- 5 x TT100104 0.9mm Tips
- 2 x TT200120 Conical Nozzles
- 2 x TT150000 Tip Adaptors

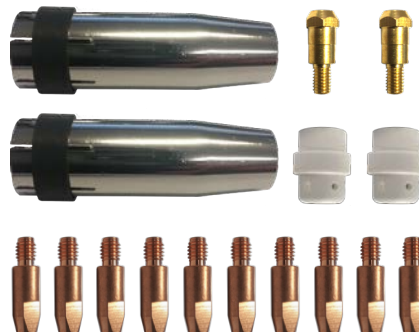

**MB24 Consumable Kits TGKIT24**

- 5 x TT100202 0.8mm Tips
- 5 x TT100204 0.9mm Tips
- 2 x TT200300 Conical Nozzles
- 2 x TT150002 Tip Adaptors
- 2 x TT300510 Gas Diffusers



**MB36 Consumable Kits TGKIT36**

- 5 x TT100204 0.9mm Tips
- 5 x TT100208 1.2mm Tips
- 2 x TT200610 Conical Nozzles
- 2 x TT150302 Tip Adaptors
- 2 x TT300530 Gas Diffusers

# BINZEL STYLE MIG CONSUMABLES



## MB15 Contact Tips

Part No.	Description	Qty
TT100100PK10	Contact Tip Steel M6 (0.6mm)	10
TT100102PK10	Contact Tip Steel M6 (0.8mm)	10
TT100104PK10	Contact Tip Steel M6 (0.9mm)	10
TT100106PK10	Contact Tip Steel M6 (1.0mm)	10
TT100108PK10	Contact Tip Steel M6 (1.2mm)	10



## MB15 Tip Holders

Part No.	Description	Qty
TT150000PK2	Contact Tip Holder M6	2



## MB24 Tip Holders

Part No.	Description	Qty
TT150002PK2	Contact Tip Holder M6 (Short)	2

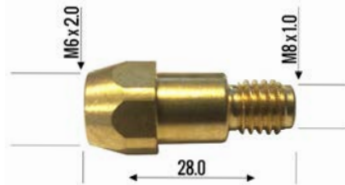

## MB24/36 Contact Tips

Part No.	Description	Qty
TT100200PK10	Contact Tip Steel M6 (0.6mm)	10
TT100202PK10	Contact Tip Steel M6 (0.8mm)	10
TT100204PK10	Contact Tip Steel M6 (0.9mm)	10
TT100206PK10	Contact Tip Steel M6 (1.0mm)	10
TT100208PK10	Contact Tip Steel M6 (1.2mm)	10
TT100212PK10	Contact Tip Steel M6 (1.6mm)	10
TT100205PK10	Contact Tip Aluminium M6 (0.9mm)	10
TT100221PK10	Contact Tip Aluminium M6 (1.0mm)	10
TT100223PK10	Contact Tip Aluminium M6 (1.2mm)	10



## MB36 Contact Tips

Part No.	Description	Qty
TT100300PK10	Contact Tip Steel M8 (0.8mm)	10
TT100311PK10	Contact Tip Steel M8 (0.9mm)	10
TT100302PK10	Contact Tip Steel M8 (1.0mm)	10
TT100304PK10	Contact Tip Steel M8 (1.2mm)	10
TT100308PK10	Contact Tip Steel M8 (1.6mm)	10

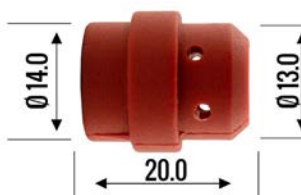
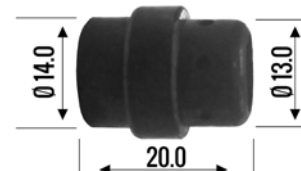
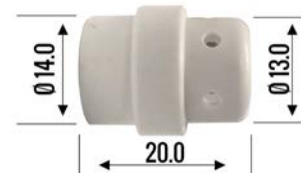

## MB24 Gas Diffuser

Part No.	Description	Qty
TT300510PK2	Gas Diffuser Ceramic	2
TT300515PK2	Gas Diffuser Duroplast	2
TFGD24PK2	Gas Diffuser Silicone	2



## MB36 Gas Diffuser

Part No.	Description	Qty
TT300530PK2	Gas Diffuser Ceramic	2
TT300525PK2	Gas Diffuser Duroplast	2
TFGD36PK2	Gas Diffuser Silicone	2

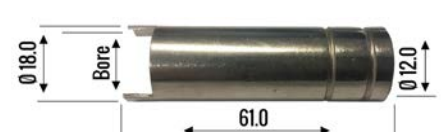
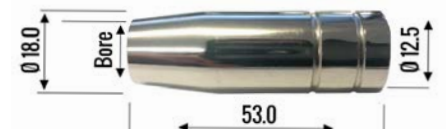
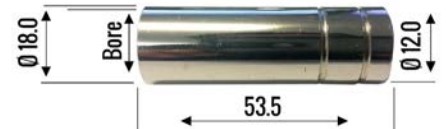

## MB15 Gas Nozzle

Part No.	Description	Qty
TT200105	Cylindrical Nozzle	2
TT200120	Conical Nozzle	2
TT200145	Tapered Nozzle	2
TT200162	Spot Nozzle	2



# BINZEL STYLE MIG CONSUMABLES



## MB24 Gas Nozzle

Part No.	Description	Qty
TT200290PK2	Cylindrical Nozzle	2
TT200300PK2	Conical Nozzle	2
TT200305PK2	Tapered Nozzle	2
TT200306PK2	Spot Nozzle	2

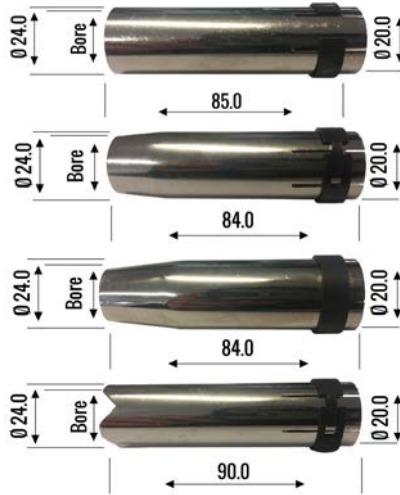

## MB36 Gas Nozzle

Part No.	Description	Qty
TT200600PK2	Cylindrical Nozzle	2
TT200610PK2	Conical Nozzle	2
TT200620PK2	Tapered Nozzle	2
TT200640PK2	Spot Nozzle	2



## Binzel Style Goose Necks

Part No.	Description	Qty
TT300030	Swan Neck M15	1
TT300032	Swan Neck M15 Flexi	1
TT300050	Swan Neck M24	1
TT300060	Swan Neck M25	1
TT300062	Swan Neck M25 Flexi	1
TT300070	Swan Neck M26	1
TT300080	Swan Neck M36	1

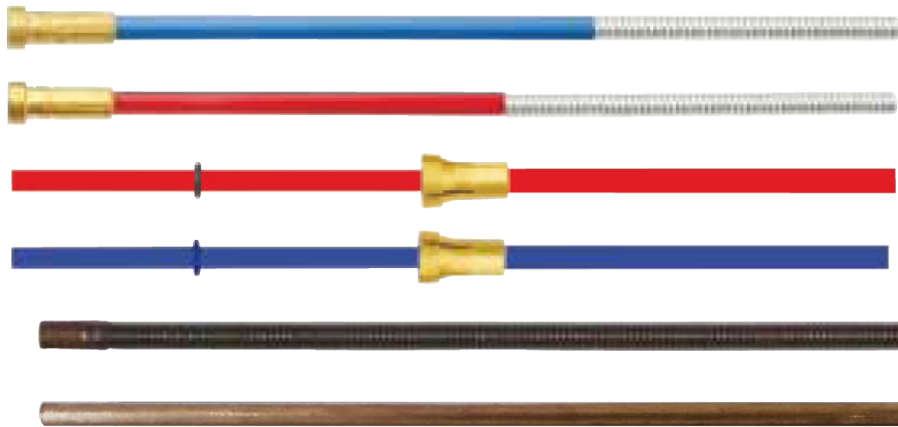

## Binzel Style Liners

Part No.	Description	Size	Length
TT301535	Blue Steel Liner	0.6mm-0.8mm	3 Metre
TT301545	Blue Steel Liner	0.6mm-0.8mm	4 Metre
TT301555	Blue Steel Liner	0.6mm-0.8mm	5 Metre
TT302535	Red Steel Liner	0.9mm-1.2mm	3 Metre
TT302545	Red Steel Liner	0.9mm-1.2mm	4 Metre
TT302555	Red Steel Liner	0.9mm-1.2mm	5 Metre
TT303635	Yellow Steel Liner	1.4mm-1.6mm	3 Metre
TT303645	Yellow Steel Liner	1.4mm-1.6mm	4 Metre
TT303655	Yellow Steel Liner	1.4mm-1.6mm	5 Metre

## Binzel Style Liners

Part No.	Description	Size	Length
TT301538	Blue Aluminium Liner	0.6mm-0.8mm	3 Metre
TT301548	Blue Aluminium Liner	0.6mm-0.8mm	4 Metre
TT302538	Red Aluminium Liner	0.9mm-1.2mm	3 Metre
TT302548	Red Aluminium Liner	0.9mm-1.2mm	4 Metre
TT303638	Yellow Aluminium Liner	1.4mm-1.6mm	3 Metre
TT303648	Yellow Aluminium Liner	1.4mm-1.6mm	4 Metre
TT1310001M45	Neck Spring For Aluminium		
TT410601	Brass Capillary Tube 2.0/5.0mm		
TT410603	Brass Capillary Tube 2.5/5.0mm		



# TWECO STYLE MIG TORCH CONSUMABLES

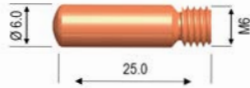

### Contact Tips

Part no.	Description	MM	Qty
TW1123	Contact Tip	0.6	10
TW1130	Contact Tip	0.8	10
TW1135	Contact Tip	0.9	10
TW1140	Contact Tip	1.0	10
TW1145	Contact Tip	1.2	10

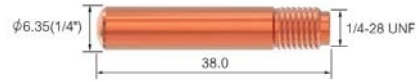

### Contact Tips

Part no.	Description	MM	Qty
TW1423PK10	Contact Tip	0.6	10
TW1430PK10	Contact Tip	0.8	10
TW14H30PK10	Contact Tip H/D	0.8	10
TW14H35PK10	Contact Tip H/D	0.9	10
TW1440PK10	Contact Tip	1.0	10
TW14H40PK10	Contact Tip H/D	1.0	10
TW14H45PK10	Contact Tip H/D	1.2	10
TW14H52PK10	Contact Tip H/D	1.3	10
TW14116	Contact Tip	1.6	10
TW14H116PK10	Contact Tip H/D	1.6	10
TW14564PK10	Contact Tip	2.0	10
TW14H564PK10	Contact Tip H/D	2.0	10

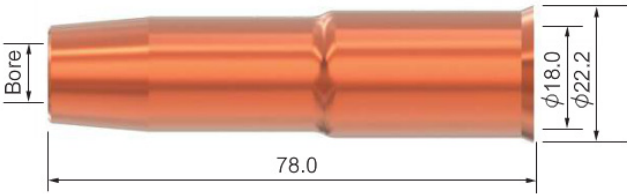

### TW NO.2 Nozzles

Part no.	Description	Bore	Qty
TW2250PK2	Adjustable Nozzle	12.8	2
TW2262PK2	Adjustable Nozzle	16.0	2

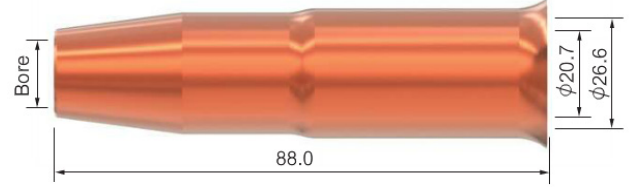

### TW NO.4 Nozzles

Part no.	Description	Bore	Qty
TW24A50PK2	Nozzle Adjustable	12.8	2
TW24A62PK2	Nozzle Adjustable	16.0	2
TW24A75PK2	Nozzle Adjustable	19.0	2

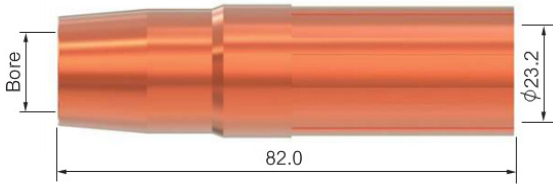

### TW NO.2 Nozzles

Part no.	Description	Bore	Qty
TW2350PK2	Nozzle Self Insulated	12.7	2
TW2362PK2	Nozzle Self Insulated	15.9	2
TW2375PK2	Nozzle Self Insulated	19.0	2

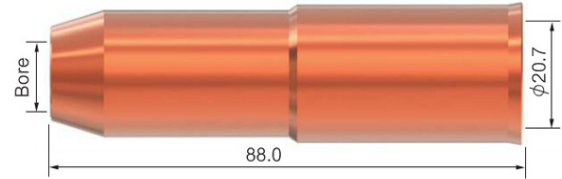

### TW NO.4 Nozzles

Part no.	Description	Bore	Qty
TW24AH50PK2	Nozzle Heavy Duty	12.8	2
TW24AH62PK2	Nozzle Heavy Duty	16.0	2
TW24AH75PK2	Nozzle Heavy Duty	19.0	2



### TW NO.2 Diffusers

Part no.	Description	Qty
TW52PK2	Diffuser	2

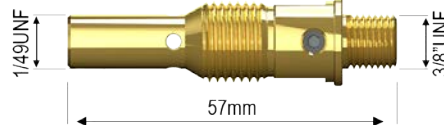

### TW NO.2 Diffusers

Part no.	Description	Qty
TW52FN	Diffuser	EA



### TW NO.4 Diffusers

Part no.	Description	Qty
TW54APK2	Diffuser	2

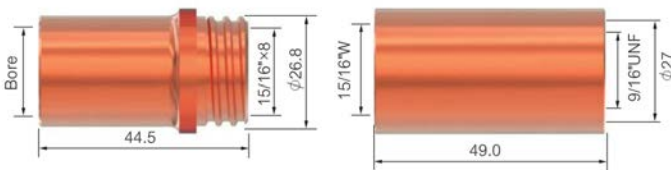

### TW NO.2 / TW NO.4 Nozzles

Part no.	Description	Bore	Qty
TW24CT50SPK2	Nozzle Fixed Coarse Thread	12.8	2
TW24CT62SPK2	Nozzle Fixed Coarse Thread	16.0	2
TW24CT75SPK2	Nozzle Fixed Coarse Thread	19.0	2
TW34CTPK2	Nozzle Insulator Coarse Thread		2

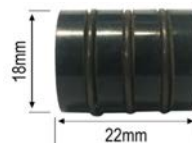

### TW NO.2 Insulators

Part no.	Description	Qty
TW32PK2	Insulator	2



### TW NO.4 Insulators

Part no.	Description	Qty
TW34APK2	Insulator	2



# TWECO STYLE MIG TORCH CONSUMABLES

## TW NO.2 LINERS

Part no.	Description	Length
TW42303515	Steel Liner x 15ft (0.8mm - 0.9mm)	4.5M
TW42354515	Steel Liner x 15ft (0.9mm - 1.2mm)	4.5M
TW42404515	Steel Liner x 15ft (1.0mm - 1.2mm)	4.5M



Part no.	Description	Length
TW42303513X	Aluminium Liner x 15ft (0.8mm - 0.9mm)	4.5M
TW42404513X	Aluminium Liner x 15ft (1.0mm - 1.2mm)	4.5M



## TW NO.4 LINERS

Part no.	Description	Length
TW44354515	Steel Liner x 15ft (0.9mm - 1.2mm)	4.90M
TW4411615	Steel Liner x 15ft (1.6mm)	4.90M
TW4456415	Steel Liner x 15ft (2.0mm)	4.90M

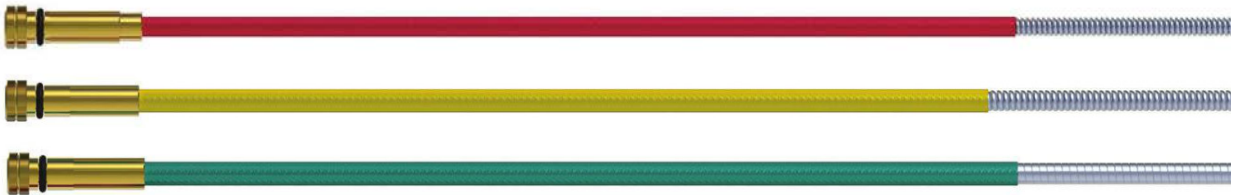

Part no.	Description	Length
TW44N11615	Aluminium Liner x 15ft (1.6mm)	4.90M



## Tweco Style Goose Necks

Part No.	Description	Qty
TW62A45	200A Goose Neck 45°	1
TW62A60	200A Goose Neck 60°	1
TW64A45	400A Goose Neck 45°	1
TW64A60	400A Goose Neck 60°	1
TW6545	500A Goose Neck 45°	1
TW6560	500A Goose Neck 60°	1



## TWECO 4 Consumable Kits

TGKITW4

- 5 x TW1435 0.9mm Tips
- 5 x TW1445 1.2mm Tips
- 2 x TW24A62 16mm Nozzles
- 1 x TW54A Gas Diffuser/Tip Holder
- 2 x TW34A Insulator

# BERNARD STYLE MIG TORCH CONSUMABLES

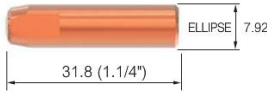

Bernard 300/400A Style Contact Tips			
Part no.	Description		Qty
BE7488PK10	Contact Tip	0.8	10
BE7489PK10	Contact Tip	0.9	10
BE7490PK10	Contact Tip	1.2	10
BE7491PK10	Contact Tip	1.6	10
BE7496PK10	Contact Tip	1.0	10
BE7498PK10	Contact Tip	1.3	10



Bernard Style 300 Amp Tip Holder		
Part no.	Description	Qty
BE4335PK2	300A Tip Holder	2



Bernard Style 400 Amp Tip Holder		
Part no.	Description	Qty
BE4435PK2	400A Tip Holder	2



Bernard Style 300 Amp Insulator		
Part no.	Description	Qty
BE4323PK2	300A Insulator	2



Bernard Style 300 Amp Nozzles		
Part no.	Description	Qty
BE4391PK2	Conical Nozzle	2
BE4392PK2	Tapered Nozzle	2



BE4393PK2	HD Conical Nozzle	2
-----------	-------------------	---

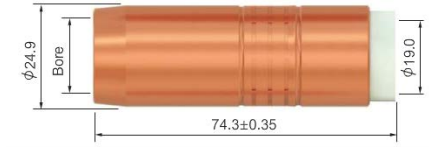

BE4591PK2	HD Conical Nozzle	2
-----------	-------------------	---



Bernard Style 400 Amp Insulator		
Part no.	Description	Qty
BE4423PK2	400A Insulator	2

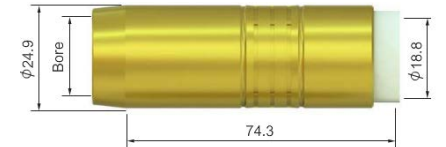

Bernard Style 400 Amp Nozzles		
Part no.	Description	Qty
BE4491PK2	Conical Nozzle	2
BE4492PK2	Tapered Nozzle	2



BE4295PK2	Pipeline Nozzle	2
-----------	-----------------	---

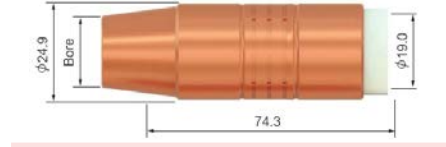

BE4592PK2	Pipeline Nozzle	2
-----------	-----------------	---



Bernard Style Liners - 300A Steel		
Part no.	Description	Length
BE43015	Steel Liner x 10ft (0.6mm - 0.8mm)	4M
BE43115	Steel Liner x 10ft (0.9mm - 1.2mm)	4M
BE43215	Steel Liner x 10ft (1.6mm)	4M



Bernard Style Liners - 400A Steel		
Part no.	Description	Length
BE44115	Steel Liner x 10ft (0.9mm - 1.2mm)	4M
BE44215	Steel Liner x 10ft (1.6mm)	4M



Bernard Style Liners - 300A Aluminium		
Part no.	Description	Length
BE43013X	Aluminium Liner x 10ft (0.6mm - 0.8mm)	4M
BE43113X	Aluminium Liner x 10ft (0.8mm - 0.9mm)	4M
BE43115X	Aluminium Liner x 10ft (0.9mm - 1.2mm)	4M
BE43315X	Aluminium Liner x 10ft (1.6mm)	4M



Bernard Style Liners - 400A Aluminium		
Part no.	Description	Length
BE44113X	Aluminium Liner x 10ft (0.9mm - 1.2mm)	4M
BE44213X	Aluminium Liner x 10ft (1.6mm)	4M



Bernard Style Swan Necks		
Part no.	Description	Qty
BE4786	Swan Neck 200A/300A	1
BE4790	Swan Neck 400A	1
BE4794	Swan Neck 500A	1

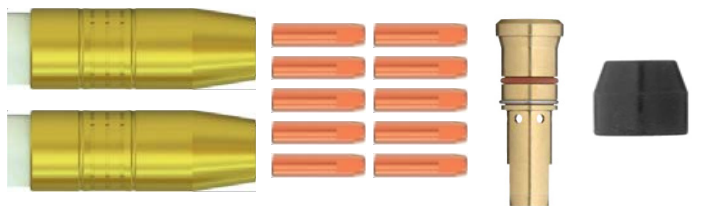

Bernard Consumable Kits		TGKITBE300
5 x BE7489 0.9mm Tips		1 x BE4323 Rubber Cap
5 x BE7490 1.2mm Tips		1 x BE4335 300A Tip Holder
2 x BE4391 Nozzles		



# MIG DRIVE ROLLERS

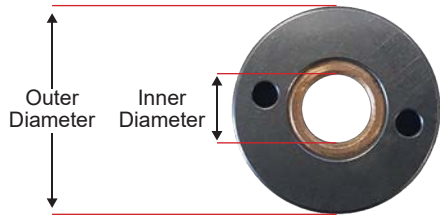

**TGRS2**

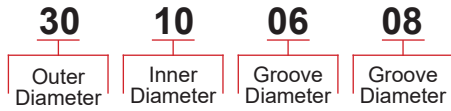

Material	Part No.	Description	165 MST	182 MS	206 MS	210L	2000 SYN Dual Pulse	255 LCD PFC	2040 5-in-1	2500 SYN Dual Pulse	3500 SYN Dual Pulse	2500 SYN Dual Pulse SWF	3500 SYN Dual Pulse SWF	355	515	5000 SYN Dual Pulse SWF / WC
<b>30/10 Rollers (With Key-way)</b>																
Steel	TGR30100608V	Roller 30/10 0.6-0.8mm Steel	•	•												
	TGR30100809V	Roller 30/10 0.8-0.9mm Steel	•	•												
	TGR30100912V	Roller 30/10 0.9-1.2mm Steel	•	•												
Gasless	TGR30100809F	Roller 30/10 0.8-0.9mm Flux	•	•												
	TGR30100912F	Roller 30/10 0.9-1.2mm Flux	•	•												
Aluminium	TGR30101012A	Roller 30/10 1.0-1.2mm Aluminium	•	•												

<b>30/10 Rollers</b>																
Steel	TGRS230100608V	Roller 30/10 0.6-0.8mm Steel				•	•	•	•	•	•	•	•	•	•	•
	TGRS230100809V	Roller 30/10 0.8-0.9mm Steel				•	•	•	•	•	•	•	•	•	•	•
	TGRS230100810V	Roller 30/10 0.8-1.0mm Steel				•	•	•	•	•	•	•	•	•	•	•
	TGRS230100912V	Roller 30/10 0.9-1.2mm Steel				•	•	•	•	•	•	•	•	•	•	•
	TGRS230101216V	Roller 30/10 1.2-1.6mm Steel				•	•	•	•	•	•	•	•	•	•	•
Gasless	TGRS230100809FC	Roller 30/10 0.8-0.9mm Flux				•	•	•	•	•	•	•	•	•	•	•
	TGRS230100912FC	Roller 30/10 0.9-1.2mm Flux				•	•	•	•	•	•	•	•	•	•	•
	TGRS230101216FC	Roller 30/10 1.2-1.6mm Flux				•	•	•	•	•	•	•	•	•	•	•
	TGRS230101416FC	Roller 30/10 1.4-1.6mm Flux				•	•	•	•	•	•	•	•	•	•	•
Aluminium	TGRS230100912U	Roller 30/10 0.9-1.2mm Aluminium				•	•	•	•	•	•	•	•	•	•	•
	TGRS230101012U	Roller 30/10 1.0-1.2mm Aluminium				•	•	•	•	•	•	•	•	•	•	•

<b>30/23 Rollers</b>																
Steel	TGR30230608V	Roller 30/23 0.6-0.8mm Steel				•	•			•						
	TGR30230809V	Roller 30/23 0.8-0.9mm Steel				•	•			•						
	TGR30230912V	Roller 30/23 0.9-1.2mm Steel				•	•			•						
	TGR30231012V	Roller 30/23 1.0-1.2mm Steel				•	•			•						
	TGR30231216V	Roller 30/23 1.2-1.6mm Steel				•	•			•						
Gasless	TGR30230608F	Roller 30/23 0.6-0.8mm Flux				•	•			•						
	TGR30230809F	Roller 30/23 0.8-0.9mm Flux				•	•			•						
	TGR30230912F	Roller 30/23 0.9-1.2mm Flux				•	•			•						
	TGR30231216F	Roller 30/23 1.2-1.6mm Flux				•	•			•						
Aluminium	TGR30230608U	Roller 30/23 0.6-0.8mm Aluminium				•	•			•						
	TGR30230910U	Roller 30/23 0.9-1.0mm Aluminium				•	•			•						
	TGR30230912U	Roller 30/23 0.9-1.2mm Aluminium				•	•			•						

<b>37/15 Rollers (With Key-way)</b>		
Steel	TGRCF37150810V	Roller 37/15 0.8-1.0mm Steel
	TGRCF37150912V	Roller 37/15 0.9-1.2mm Steel
	TGRCF37151216V	Roller 37/15 1.2-1.6mm Steel
Gasless	TGRCF37150912F	Roller 37/15 0.9-1.2mm Flux
	TGRCF37151216F	Roller 37/15 1.2-1.6mm Flux
	TGRCF371524F	Roller 37/15 2.4mm Flux

<b>37/19 Rollers</b>		
Steel	TGR37190608V	Roller 37/19 0.6-0.8mm Steel
	TGR37190809V	Roller 37/19 0.8-0.9mm Steel
	TGR37190810V	Roller 37/19 0.8-1.0mm Steel
	TGR37190912V	Roller 37/19 0.9-1.2mm Steel
	TGR37191216V	Roller 37/19 1.2-1.6mm Steel
Gasless	TGR37190809F	Roller 37/19 0.8-0.9mm Flux
	TGR37190912F	Roller 37/19 0.9-1.2mm Flux
	TGR37191216F	Roller 37/19 1.2-1.6mm Flux
Aluminium	TGR37190809U	Roller 37/19 0.8-0.9mm Aluminium
	TGR37190912U	Roller 37/19 0.9-1.2mm Aluminium
	TGR37191216U	Roller 37/19 1.2-1.6mm Aluminium



30/10 Roller (with Key-way)



30/10 Roller (Standard)



30/23 Roller (with Key-way)



37/15 Roller (with Key-way)



37/19 Roller (Standard)

# WELDING ACCESSORIES

## Welding Trolleys



Description	To suit	Part Number
3 Tier Trolley + Bottle Stand	<ul style="list-style-type: none"> <li>I-Arc 145</li> <li>I-Arc 200</li> <li>165 MST</li> <li>182 MS</li> <li>195 DC Tig</li> <li>210L</li> <li>215E AC/DC</li> </ul>	TGWTS



3 Tier Trolley + Bottle Stand Heavy Duty	<ul style="list-style-type: none"> <li>206 MS</li> </ul>	TGWTSHD
2 Tier Trolley + Bottle Stand Heavy Duty	<ul style="list-style-type: none"> <li>Most Single Phase Machines</li> <li>200 4-in-1</li> <li>206 MS</li> <li>2000 Dual Pulse</li> <li>255 PFC LCD</li> <li>2040 5-in-1</li> <li>2000 AC/DC Pulse Tig</li> </ul>	TGWTS2T



Compact Trolley + Storage Drawer Heavy Duty	<ul style="list-style-type: none"> <li>200 4-in-1</li> <li>2040 5-in-1</li> <li>255 PFC LCD</li> <li>355F</li> <li>515F</li> </ul>	TGWTS5HD
---	--	----------

## Machine Carry Bags



Description	To suit	Part Number
Top Gun Machine Bag Small	<ul style="list-style-type: none"> <li>I-Arc 145</li> <li>I-Arc 200</li> <li>195 DC Tig</li> <li>215E AC/DC</li> </ul>	TGBAGS

Top Gun Machine Bag Large	<ul style="list-style-type: none"> <li>165 MST</li> <li>182 MS</li> <li>206 MS</li> <li>210L</li> <li>2000 SYN Pulse</li> <li>2000 AC/DC</li> <li>200 4-in-1</li> <li>2040 5-in-1</li> </ul>	TGBAGL
---------------------------	--	--------

## Optional Mig Torches



Description	To suit	Part Number
Spool Gun 200A	<ul style="list-style-type: none"> <li>182 MS</li> <li>206 MS</li> <li>210L</li> <li>2000 SYN</li> <li>255 LCD PFC</li> <li>2500</li> <li>2040 5-in-1</li> <li>2500 SWF</li> <li>3500</li> <li>3500 SWF</li> <li>5000 SWF / WC</li> </ul>	TGTS200

## Tig Accessories

Description	Part Number	Description	Part Number
 Series 1 Foot Control	TGFCS1	 Series 2 Wireless Remote Foot Control	TGWRFC
 Series 2 Foot Control	TGWS2FC	 Wireless TIG Remote to suit 325 AC/DC	TGDPWRC
 1000 Series Foot Control	TGWTIGFC1000	 Distilled Water 5L For Top Gun Water Coolers	ACM08655



## Cable Plugs and Sockets



Description	Part Number
Cable Connector Plug 10 - 25mm	TTCC305150
Cable Connector Plug 35 - 50mm	TTCC305152
Cable Connector Plug 70 - 95mm	TTCC7095P



Description	Part Number
Cable Connector Socket 10 - 25mm	TTCC305160
Cable Connector Socket 35 - 50mm	TTCC305162
Cable Connector Socket 70 - 95mm	TTCC7095S

## Panel Sockets



Description	Part Number
Panel Socket 10mm - 25mm	TTCC305170
Panel Socket 35mm - 50mm	TTCC305172
Panel Socket 50mm - 70mm	TTCCPS5070
Panel Socket 70mm - 95mm	TTCCPS7095

## Earth Clamps



Description	Part Number
Earth Clamp 200 Amp - Standard	ACCLP200
Earth Clamp 300 Amp - Screw Down	ACCLP300
Earth Clamp 400 Amp - Brass	ACCLP400B
Earth Clamp 500 Amp - Standard	ACCLP500
Earth Clamp 500 Amp - G Style	ACCLP500G
Earth Clamp 500 Amp - Heavy Duty	ACCLP500H
Earth Clamp 600 Amp - Screw Down	ACCLP600S

## Mech Connectors

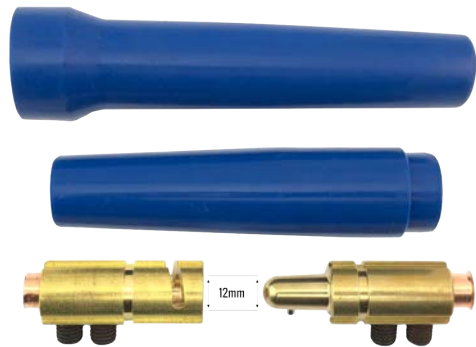

Description	Part Number
Cable Connector 500A 35mm - 50mm	ACCC500

## Electrode Holder



Description	Part Number
Electrode Holder - Tong Type - 300A	ACEHTT300
Electrode Holder - Tong Type - 400A	ACEHTT400
Electrode Holder - Tong Type - 500A	ACEHTT500
Electrode Holder - Twist Lock - 400A	ACEHTL400

## Lead Sets



Description	Part Number
Earth & Arc Lead Set 35mm <sup>2</sup> Cable 5 MTR 35mm - 50mm	LEH35535
Earth & Arc Lead Set 35mm <sup>2</sup> Cable 10 MTR 35mm - 50mm	LEH351035

## Cable Lugs



Description	Part Number
Crimp Lug 16mm x 10mm Hole	LU16M10
Crimp Lug 16mm x 12mm Hole	LU16M12
Crimp Lug 25mm x 10mm Hole	LU25M10
Crimp Lug 25mm x 12mm Hole	LU25M12
Crimp Lug 35mm x 10mm Hole	LU35M10
Crimp Lug 35mm x 12mm Hole	LU35M12
Crimp Lug 50mm x 10mm Hole	LU50M10
Crimp Lug 50mm x 12mm Hole	LU50M12
Crimp Lug 70mm x 12mm Hole	LU70M12
Crimp Lug 95mm x 12mm Hole	LU95M12
Crimp Lug 120mm x 12mm Hole	LU120M12

*More sizes available - Contact us for whole range.*

## OTK Clips



Description	Part Number
OTK Clip 5mm - 7mm	OTK57
OTK Clip 7mm - 9mm	OTK79
OTK Clip 9mm - 11mm	OTK911
OTK Clip 11mm - 13mm	OTK1113
OTK Clip 13mm - 15mm	OTK1315
OTK Clip 15mm - 17mm	OTK1517
OTK Clip 17mm - 20mm	OTK1520
OTK Clip 19mm - 25mm	OTK1925
OTK Clip 20mm - 23mm	OTK2023
OTK Clip 28mm - 31mm	OTK2831
OTK Clip 34mm - 37mm	OTK3437

## Electrode Ovens



Description	Part Number
Electrode Oven 5Kg	PTEO65KG
Electrode Oven 10Kg	PTEO610KG

## Anti-Spatter



Description	Part Number
Top Gun Anti-Spatter 400ml	TGACON400

## Mig Pliers



Description	Part Number
Topgun Mig Pliers 8"	TGACPLIER

## Wire Brushes



Description	Part Number
Wire Brush 3 Row Steel	ACB3
Wire Brush 3 Row Stainless Steel Long Handle	ACB421
Wire Brush 3 Row Stainless Steel Converged	ACB429
Wire Brush 4 Row Steel	ACB4
Wire Brush 4 Row Steel Long Handle	ACB400
Wire Brush 4 Row Stainless Steel Long Handle	ACB420
Wire Brush Stainless Steel 3X7 "Toothbrush"	ACB85055

## Magnetic Welding Clamps



Description	Part Number
Magnetic Welding Clamp 25LB/11KG	MA11KG
Magnetic Welding Clamp 50LB/22KG	MA22KG
Magnetic Welding Clamp 75LB/33KG	MA33KG

## Gouging Carbons



Description	Part Number
Gouging Carbon DC 5mm x 305mm	CAGR5
Gouging Carbon DC 6.5mm x 305mm	CAGR65
Gouging Carbon DC 8mm x 305mm	CAGR8
Gouging Carbon DC 9.5mm x 305mm	CAGR95
Gouging Carbon DC Flat 5mm x 15mm x 355mm	CAGF515
Gouging Carbon DC Jointed 13mm x 430mm	CAGR13J



# WELDING WIRE

## Mild Steel Mig Wire



Part No.	Description
CWM061TG	Topgun 0.6mm 1kg Mild Steel Wire
CWM0605	Topgun 0.6mm 5kg Mild Steel Wire
CWM081TG	Topgun 0.8mm 1kg Mild Steel Wire
CWM082B	Topgun 0.8mm 5kg Mild Steel Wire
CWM084B	Topgun 0.8mm 15kg Mild Steel Wire
CWM091TG	Topgun 0.9mm 1kg Mild Steel Wire
CWM093B	Topgun 0.9mm 5kg Mild Steel Wire
CWM095B	Topgun 0.9mm 15kg Mild Steel Wire
CWMTGER70S609	Topgun 0.9mm 250kg Mild Steel Wire
CWM103B	Topgun 1.0mm 1kg Mild Steel Wire
CWM1255	Topgun 1.2mm 15kg Mild Steel Wire
CWMTGER70S612	Topgun 1.2mm 250kg Mild Steel Wire

## Aluminium Mig Wire



Part No.	Description
CWATG0508	Topgun 0.8mm 0.5kg 5356 Aluminium Wire
CWATG208	Topgun 0.8mm 2kg 5356 Aluminium Wire
CWATG0509	Topgun 0.9mm 0.5kg 5356 Aluminium Wire
CWATG209	Topgun 0.9mm 2kg 5356 Aluminium Wire
CWA5356TG09	Topgun 0.9mm 7kg 5356 Aluminium Wire
CWATG0510	Topgun 1.0mm 0.5kg 5356 Aluminium Wire
CWATG210	Topgun 1.0mm 2kg 5356 Aluminium Wire
CWA5356TG10	Topgun 1.0mm 7kg 5356 Aluminium Wire
CWATG0512	Topgun 1.2mm 0.5kg 5356 Aluminium Wire
CWATG212	Topgun 1.2mm 2kg 5356 Aluminium Wire
CWA5356TG12	Topgun 1.2mm 7kg 5356 Aluminium Wire

## Metal Core Mig Wire



Part No.	Description
CWFM1270C6MH415K	Topgun 1.2mm 15kg E70C-6M H4 Metal Core Wire
CWFM1270C6MH4	Topgun 1.2mm 200kg E70C-6M H4 Metal Core Wire
CWFM1670C6MH415K	Topgun 1.6mm 15kg E70C-6M H4 Metal Core Wire

## Stainless Steel Mig Wire



Part No.	Description
CWS316091W	Topgun 0.9mm 1kg 316 Stainless Steel Wire
CWS316092W	Topgun 0.9mm 5kg 316 Stainless Steel Wire
CWS316093	Topgun 0.9mm 15kg 316 Stainless Steel Wire
CWS316122	Topgun 1.2mm 15kg 316 Stainless Steel Wire

## Flux Cored Gasless Mig Wire



Part No.	Description
CWFM085A	Topgun 0.8mm 0.9kg Flux Cored Gasless Wire
CWFM083B	Topgun 0.8mm 4.5kg Flux Cored Gasless Wire
CWFM092	Topgun 0.9mm 0.9kg Flux Cored Gasless Wire
CWFM093A	Topgun 0.9mm 4.5kg Flux Cored Gasless Wire
CWFM094A	Topgun 0.9mm 15kg Flux Cored Gasless Wire
CWFM101	Topgun 1.0mm 0.9kg Flux Cored Gasless Wire
CWFM102	Topgun 1.0mm 4.5kg Flux Cored Gasless Wire
CWFM124A	Topgun 1.2mm 15kg Flux Cored Gasless Wire

## Flux Cored Gas Shielded Mig Wire



Part No.	Description
CWFM122CO2	Topgun 1.2mm 15kg E71T-1 Co2 Shielded Flux Cored Wire
CWFM162CO2	Topgun 1.6mm 15kg E71T-1 Co2 Shielded Flux Cored Wire



Part No.	Description
CW81NI12TG	Topgun 1.2mm 15kg 81Ni-1 Gas Shielded Flux Cored Wire
CW81NI16TG	Topgun 1.6mm 15kg 81Ni-1 Gas Shielded Flux Cored Wire

# WELDING WIRE



## 6013 General Purpose Welding Electrode

Part No.	Description
CETG6013GP0525	Topgun 2.5mm 0.5kg 6013 General Purpose Welding Electrode
CETG6013GP0532	Topgun 3.2mm 0.5kg 6013 General Purpose Welding Electrode



## 312-16 Dissimilar Metals Welding Electrode

Part No.	Description
CETG312160525	Topgun 2.5mm 0.5kg 312-16 Dissimilar Metals Welding Electrode
CETG312160532	Topgun 3.2mm 0.5kg 312-16 Dissimilar Metals Welding Electrode



## Hard Facing Welding Electrode

Part No.	Description
CETGHF0532	Topgun 3.2mm 0.5kg Hard Facing Welding Electrode



## 316L-16 Stainless Steel Welding Electrode

Part No.	Description
CETG316L160525	Topgun 2.5mm 0.5kg 316L-16 Stainless Steel Welding Electrode
CETG316L160532	Topgun 3.2mm 0.5kg 316L-16 Stainless Steel Welding Electrode



## 7016 Low Hydrogen Welding Electrode

Part No.	Description
CETG70160525	Topgun 2.5mm 0.5kg 7016 Low Hydrogen Welding Electrode
CETG70160532	Topgun 3.2mm 0.5kg 7016 Low Hydrogen Welding Electrode



## Cast Iron NiFe 98 Welding Electrode

Part No.	Description
CETGNIFE0525	Topgun 2.6mm 0.5kg Cast Iron Welding Electrode

## Filler Wire



## Mild Steel Tig Filler Wire

Part No.	Description
CWRF70S6165	Topgun 1.6mm 5kg Mild Steel Tig Filler Wire
CWRF70S6245	Topgun 2.4mm 5kg Mild Steel Tig Filler Wire

## Stainless Steel Tig Filler Wire

Part No.	Description
CWRFS316165	Topgun 1.6mm 5kg Stainless Steel Tig Filler Wire
CWRFS316245	Topgun 2.4mm 5kg Stainless Steel Tig Filler Wire

## Aluminium Tig Filler Wire

Part No.	Description
CWRF404324A	Topgun 2.4mm 1kg 4043 Aluminium Tig Filler Wire
CWRF404324	Topgun 2.4mm 5kg 4043 Aluminium Tig Filler Wire
CWRF5356241	Topgun 2.4mm 1kg 5356 Aluminium Tig Filler Wire
CWRF53562425	Topgun 2.4mm 2.5kg 5356 Aluminium Tig Filler Wire
CWRF5356321	Topgun 3.2mm 1kg 5356 Aluminium Tig Filler Wire
CWRF53563225	Topgun 3.2mm 2.5kg 5356 Aluminium Tig Filler Wire

## Ceramic Backing Tape



Part No.	Description
ACB1006RD	Ceramic Backing CB-10 Tape 6mm Round 12MTR
ACB1009RD	Ceramic Backing CB-10 Tape 9mm Round 12MTR
ACB1012RD	Ceramic Backing CB-10 Tape 12mm Round 12MTR
ACB112812	Ceramic Backing CB-11 Tape 28mm x 12mm Round 12MTR
ACB162868	Ceramic Backing CB-16 Tape 28mm x 6mm Round 9MTR



# TIG TORCHES



Topgun Tig 17V	Part No.
Topgun Tig 17V 4 Metre 10-25mm Dinse Connection	TGT17V425
Topgun Tig 17V 4 Metre 35-50mm Dinse Connection	TGT17V435
Topgun Tig 17V 8 Metre 35-50mm Dinse Connection	TGT17V835



Topgun Tig 18 Water Cooled	Part No.
Topgun Tig 18 4 Metre 12 Pin Series II 35-50mm Dinse Connection, Micro Switch, Thumb Control	TGT18412P
Topgun Tig 18 8 Metre 12 Pin Series II 35-50mm Dinse Connection, Micro Switch, Thumb Control	TGT18812P



Topgun Tig 26	Part No.
Topgun Tig 26 4 Metre 9 Pin Series II/5/1000 35-50mm Dinse Connection, Micro Switch, Thumb Control	TGT2649P
Topgun Tig 26 4 Metre 12 Pin 35-50mm Dinse Connection, Micro Switch, Thumb Control	TGT26412P
Topgun Tig 26 8 Metre 12 Pin Series II 35-50mm Dinse Connection, Micro Switch, Thumb Control	TGT26812P



## Tig Consumable Kits

TGKITTIG

1 x TI57Y02 Long Back Cap	1 x TI10N25 Collet, 3.2MM
1 x TI10N50 Ceramic Nozzle, Size 4, 6MM	1 x TI10N31 Collet Body 1.6MM
1 x TI10N49 Ceramic Nozzle, Size 5, 8MM	1 x TI10N32 Collet Body 2.4MM
1 x TI10N48 Ceramic Nozzle, Size 6, 10MM	1 x TI10N28 Collet Body 3.2MM
1 x TI10N47 Ceramic Nozzle, Size 7, 11MM	1 x TITG16 Lanthanated Tungsten 1.6MM
1 x TI10N23 Collet, 1.6MM	1 x TITG24 Lanthanated Tungsten 2.4MM
1 x TI10N24 Collet, 2.4MM	1 x TITG32 Lanthanated Tungsten 3.2MM



## Tig Gas Lens Consumable Kits

TGKITLENST

1 x TI57Y02 Long Back Cap	1 x TI45V27 Gas Lens Collet Body, 3.2MM
1 x TI54N01 Gasket	1 x TI54N17 Ceramic Nozzle Size 5, 8MM
1 x TI10N23 Collet, 1.6MM	1 x TI54N16 Ceramic Nozzle Size 6, 10MM
1 x TI10N24 Collet, 2.4MM	1 x TI54N14 Ceramic Nozzle Size 8, 13MM
1 x TI10N25 Collet, 3.2MM	1 x TITG16 Lanthanated Tungsten 1.6MM
1 x TI45V25 Gas Lens Collet Body, 1.6MM	1 x TITG24 Lanthanated Tungsten 2.4MM
1 x TI45V26 Gas Lens Collet Body, 2.4MM	1 x TITG32 Lanthanated Tungsten 3.2MM

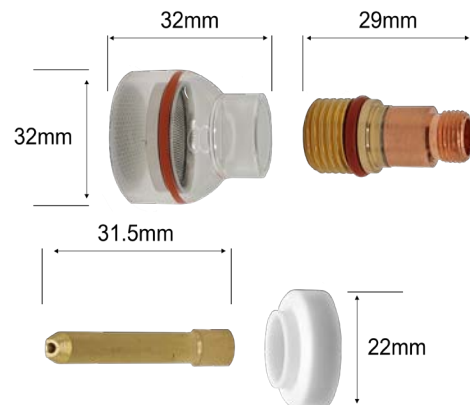
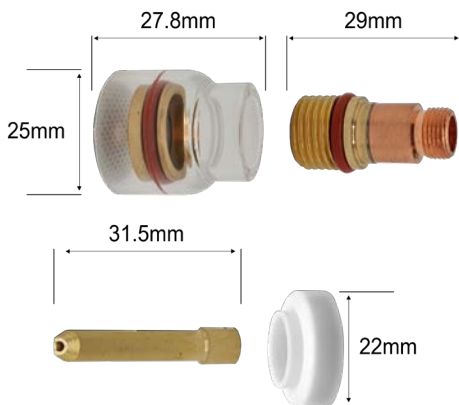

### Tig Quartz Cup Gas Lens Set - Small

Quartz Cup Kit Small - 1.6mm	TIQC16SKIT
Quartz Cup Kit Small - 2.4mm	TIQC24SKIT

### Tig Quartz Cup Gas Lens Set - Large

Quartz Cup Kit Large - 1.6mm	TIQC16LKIT
Quartz Cup Kit Large - 2.4mm	TIQC24LKIT

# TIG 9/20 CONSUMABLES

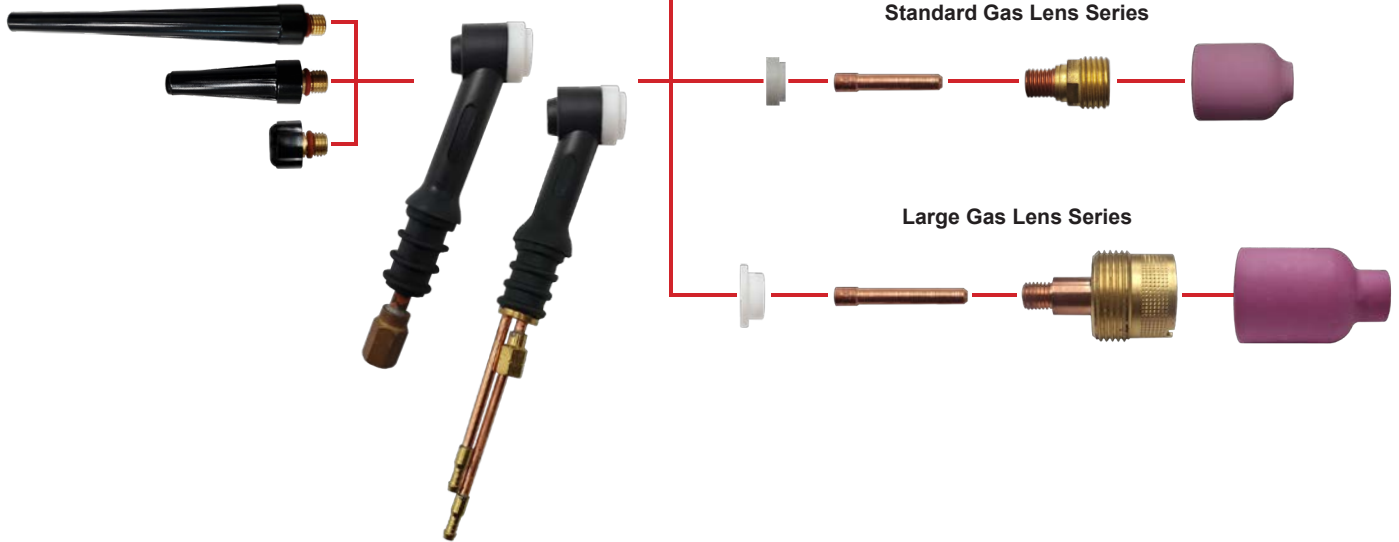

Series	Part No.	Description
9/20 Back Caps	41V33	Back Cap Short
	41V35	Back Cap Medium
	41V24	Back Cap Long

Series	Part No.	Description
9 Series TIG Body	T9	Tig Body 130A Standard
	T9V	Tig Body 130A Standard + Valve
	T9F	Tig Body 130A Flexible
	T9FV	Tig Body 130A Flexible + Valve
20 Series TIG Body	T20	Tig Body 250A Standard Water Cooled
	T20F	Tig Body 250A Flexible Water Cooled
	T20V	Tig Body 250A Standard Water Cooled + Valve

## Standard Series

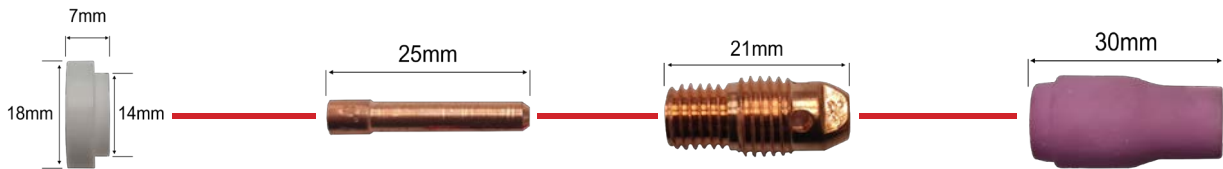

Series	Part No.	Description	Part No.	Description	Part No.	Description	Part No.	Description
Standard Series	598882	Cup Gasket	13N21	Collet 1.0mm	13N26	Collet Body 1.0mm	13N08	Alumina Nozzle Ø 6mm
			13N22	Collet 1.6mm	13N27	Collet Body 1.6mm	13N09	Alumina Nozzle Ø 8mm
			13N23	Collet 2.4mm	13N28	Collet Body 2.4mm	13N10	Alumina Nozzle Ø 10mm
			13N24	Collet 3.2mm	13N29	Collet Body 3.2mm	13N11	Alumina Nozzle Ø 11mm
							13N12	Alumina Nozzle Ø 12.5mm
							13N13	Alumina Nozzle Ø 13mm



# TIG 9/20 CONSUMABLES

## Standard Gas Lens Series

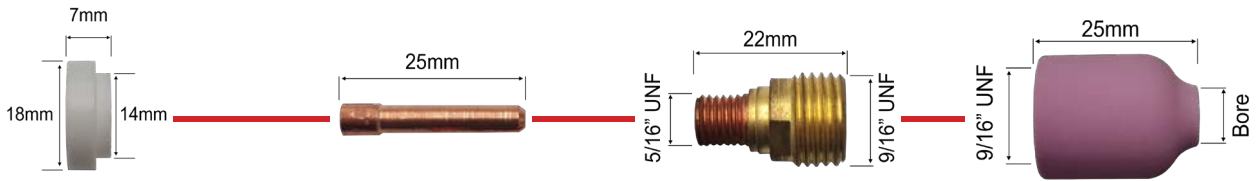

Series	Part No.	Description	Part No.	Description	Part No.	Description	Part No.	Description
Standard Series	598882	Cup Gasket	13N21	Collet 1.0mm	45V42	Gas Lens Collet Body 1.0mm	53N58	Alumina Nozzle Ø 6mm
			13N22	Collet 1.6mm	45V43	Gas Lens Collet Body 1.6mm	53N59	Alumina Nozzle Ø 8mm
			13N23	Collet 2.4mm	45V44	Gas Lens Collet Body 2.4mm	53N60	Alumina Nozzle Ø 10mm
			13N24	Collet 3.2mm	45V45	Gas Lens Collet Body 3.2mm	53N61	Alumina Nozzle Ø 11mm
							53N61S	Alumina Long Nozzle Ø 12.5mm

## Large Gas Lens Series

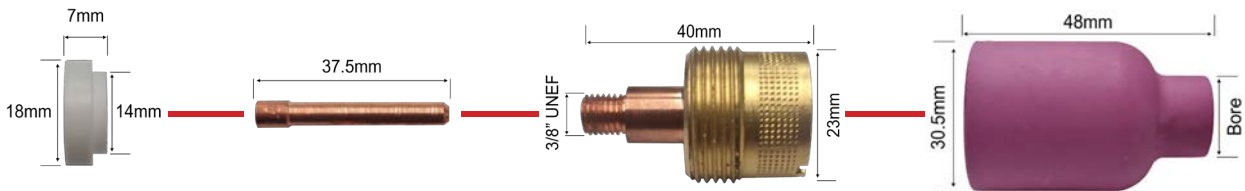

Series	Part No.	Description	Part No.	Description	Part No.	Description	Part No.	Description
Standard Series	598882	Cup Gasket	13N21L	Collet 1.0mm	45V0204S	Gas Lens Collet Body 1.0mm	57N75	Alumina Nozzle Ø 10mm
			13N22L	Collet 1.6mm	45V116S	Gas Lens Collet Body 1.6mm	57N74	Alumina Nozzle Ø 12.5mm
			13N23L	Collet 2.4mm	45V64S	Gas Lens Collet Body 2.4mm	53N88	Alumina Nozzle Ø 16mm
			13N24L	Collet 3.2mm	995795S	Gas Lens Collet Body 3.2mm	53N87	Alumina Nozzle Ø 19mm



Part#	Description
TITG16	1.6mm x 175mm Lanthanated Tungsten Electrode 1.5%
TITG24	2.4mm x 175mm Lanthanated Tungsten Electrode 1.5%
TITG32	3.2mm x 175mm Lanthanated Tungsten Electrode 1.5%



Part#	Description
TITL16	1.6mm x 175mm Lanthanated Tungsten Electrode 1%
TITL24	2.4mm x 175mm Lanthanated Tungsten Electrode 1%
TITL32	3.2mm x 175mm Lanthanated Tungsten Electrode 1%



Part#	Description
TITZ16	1.6mm x 175mm Zirconiated Tungsten Electrode 1%
TITZ24	2.4mm x 175mm Zirconiated Tungsten Electrode 1%
TITZ32	3.2mm x 175mm Zirconiated Tungsten Electrode 1%



Part#	Description
TITC16	1.6mm x 175mm Ceriated Tungsten Electrode 2%
TITC24	2.4mm x 175mm Ceriated Tungsten Electrode 2%
TITC32	3.2mm x 175mm Ceriated Tungsten Electrode 2%



Part#	Description
TITT16	1.6mm x 175mm Thoriated Tungsten Electrode 2%
TITT24	2.4mm x 175mm Thoriated Tungsten Electrode 2%
TITT32	3.2mm x 175mm Thoriated Tungsten Electrode 2%

# TIG 17/18/26 CONSUMABLES

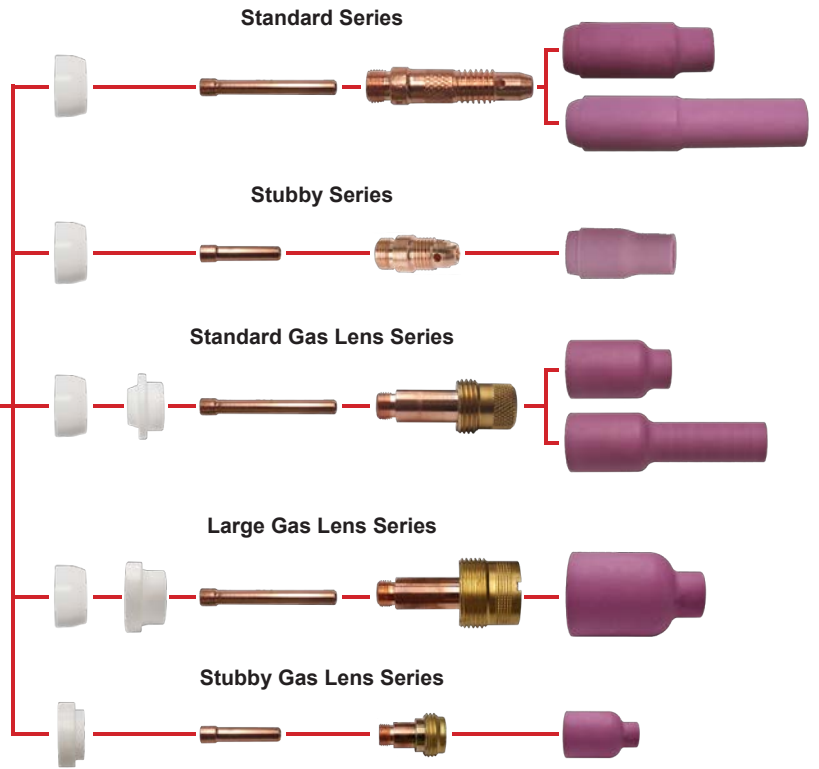

Series	Part No.	Description
17/18/26 Back Caps	57Y04	Back Cap Short
	57Y03	Back Cap Medium
	57Y02	Back Cap Long

Series	Part No.	Description
17/18/26 TIG Body	17V	Tig Body 150A Standard + Valve
	17F	Tig Body 150A Flexible
	17FV	Tig Body 150A Flexible + Valve

## Standard Series

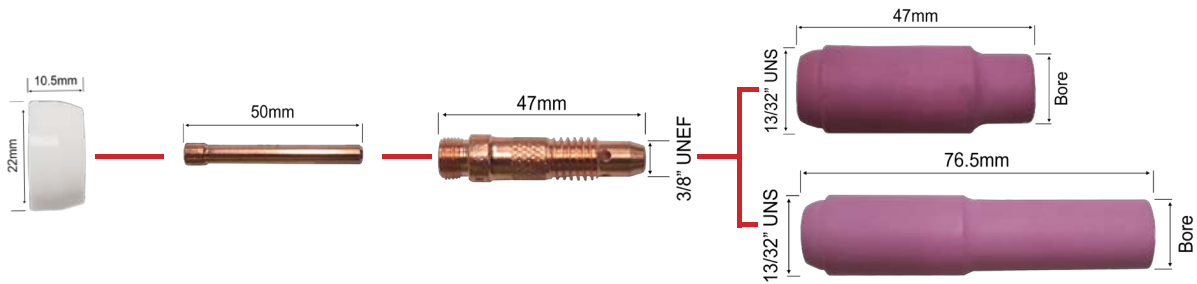

Series	Part No.	Description	Part No.	Description	Part No.	Description	Part No.	Description
Standard Series	18CG	Cup Gasket	10N22	Collet 1.0mm	10N30	Collet Body 1.0mm	10N50	Alumina Nozzle Ø 6mm #4
			10N23	Collet 1.6mm	10N31	Collet Body 1.6mm	10N49	Alumina Nozzle Ø 8mm #5
			10N24	Collet 2.4mm	10N32	Collet Body 2.4mm	10N48	Alumina Nozzle Ø 10mm #6
			10N25	Collet 3.2mm	10N28	Collet Body 3.2mm	10N47	Alumina Nozzle Ø 11mm #7
							10N46	Alumina Nozzle Ø 13mm #8
							10N45	Alumina Nozzle Ø 16mm #10
							10N44	Alumina Nozzle Ø 19mm #12
							10N49L	Long Alumina Nozzle Ø 8mm #5L
							53N48L	Long Alumina Nozzle Ø 10mm #6L
							53N47L	Long Alumina Nozzle Ø 11mm #7L

# TIG 17/18/26 CONSUMABLES CONTINUED

## Stubby Series

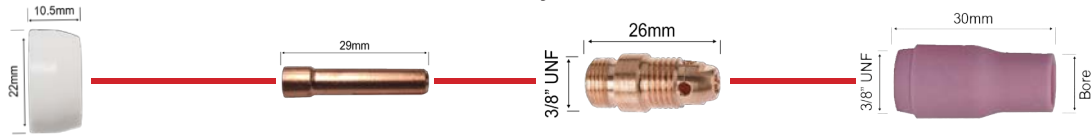

Series	Part No.	Description	Part No.	Description	Part No.	Description	Part No.	Description
Stubby Series	18CG	Cup Gasket	10N22S	Collet 1.0mm Stubby	17CB20	Collet Body 1.0mm - 3.2mm Stubby	13N08	Alumina Nozzle Ø 6mm #4 Stubby
			10N23S	Collet 1.6mm Stubby			13N09	Alumina Nozzle Ø 8mm #5 Stubby
			10N24S	Collet 2.4mm Stubby			13N10	Alumina Nozzle Ø 10mm #6 Stubby
			10N25S	Collet 3.2mm Stubby			13N11	Alumina Nozzle Ø 11mm #7 Stubby
							13N12	Alumina Nozzle Ø 13mm #8 Stubby
							13N13	Alumina Nozzle Ø 16mm #10 Stubby

## Standard Gas Lens Series

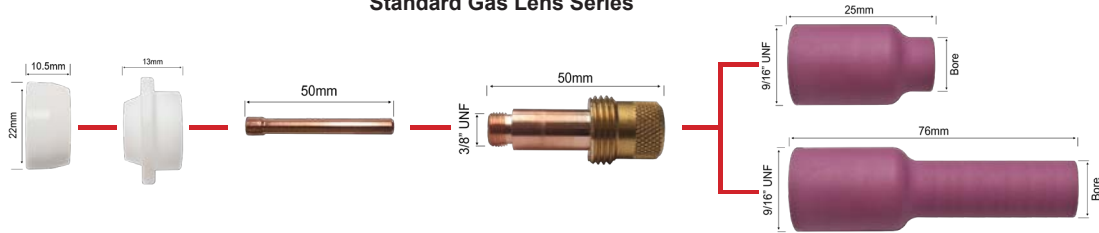

Series	Part No.	Description	Part No.	Description	Part No.	Description	Part No.	Description	Part No.	Description
Standard Gas Lens Series	18CG	Cup Gasket	54N01	Gas Insulator	10N22	Collet 1.0mm	45V24	Gas Lens Collet Body 1.0mm	54N18	Alumina Nozzle Ø 6mm #4
					10N23	Collet 1.6mm	45V25	Gas Lens Collet Body 1.6mm	54N17	Alumina Nozzle Ø 8mm #5
					10N24	Collet 2.4mm	45V26	Gas Lens Collet Body 2.4mm	54N16	Alumina Nozzle Ø 10mm #6
					10N25	Collet 3.2mm	45V27	Gas Lens Collet Body 3.2mm	54N15	Alumina Nozzle Ø 11mm #7
									54N14	Alumina Nozzle Ø 13mm #8
									54N19	Alumina Nozzle Ø 16mm #11
									54N17L	Long Alumina Nozzle Ø 8mm #5L
									54N16L	Long Alumina Nozzle Ø 10mm #6L
									54N15L	Long Alumina Nozzle Ø 11mm #7L
									54N14L	Long Alumina Nozzle Ø 12.7mm #8L

## Large Gas Lens Series

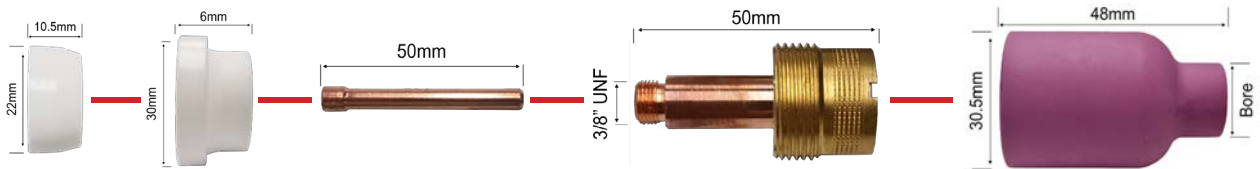

Series	Part No.	Description	Part No.	Description	Part No.	Description	Part No.	Description	Part No.	Description
Large Gas Lens Series	18CG	Cup Gasket	54N63	Gas Insulator	10N23	Collet 1.6mm	45V116	Gas Lens Large Body 1.6mm	57N75	Alumina Nozzle Ø 10mm #6
					10N24	Collet 2.4mm	45V64	Gas Lens Large Body 2.4mm	57N74	Alumina Nozzle Ø 13mm #8
					10N25	Collet 3.2mm	995795	Gas Lens Large Body 3.2mm	53N88	Alumina Nozzle Ø 15.8mm
									53N87	Alumina Nozzle Ø 19mm
									53N89	Alumina Nozzle Ø 24mm

## Stubby Gas Lens Series

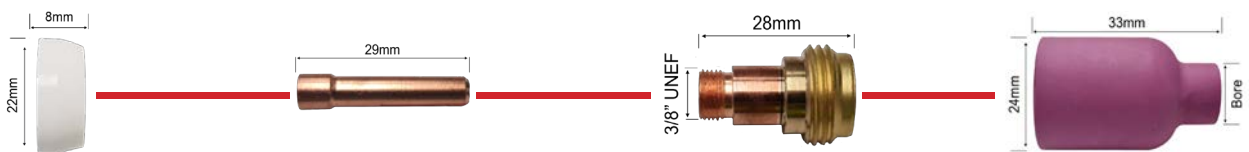

Series	Part No.	Description	Part No.	Description	Part No.	Description	Part No.	Description
Stubby Gas Lens Series	18CG20	Cup Gasket	10N23S	Collet 1.6mm Stubby	45V116S	Gas Lens Stubby Body 1.6mm	54N12SW	Alumina Nozzle Ø 16mm
			10N24S	Collet 2.4mm Stubby	45V26S	Gas Lens Stubby Body 2.4mm	54N14SW	Alumina Nozzle Ø 12.5mm
			10N25S	Collet 3.2mm Stubby	45V27S	Gas Lens Stubby Body 3.2mm	54N15SW	Alumina Nozzle Ø 11mm
							54N16SW	Alumina Nozzle Ø 10mm



## Topgun PT31 Plasma Torch

### Air-Cooled Plasma Cutting Torch

To Suit Topgun Plasma CUT-40M (Old style)

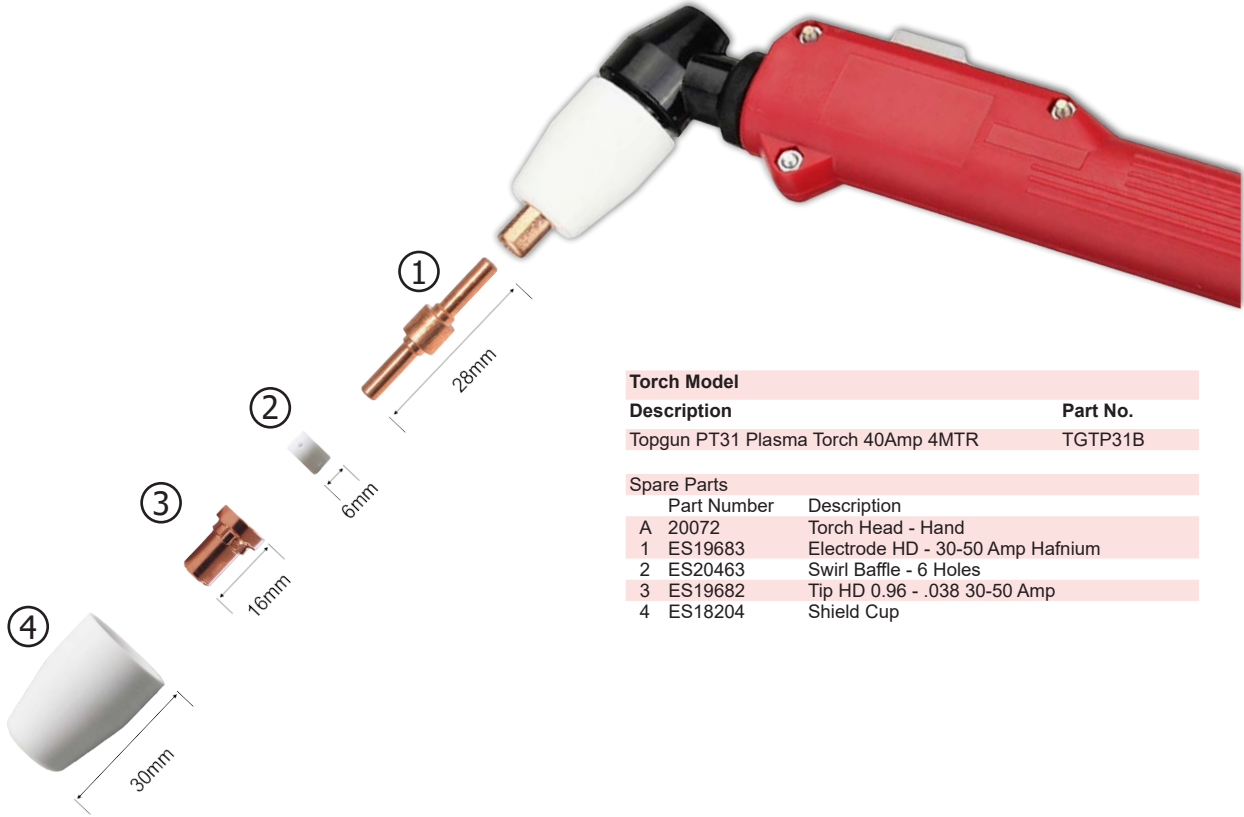

Torch Model	
Description	Part No.
Topgun PT31 Plasma Torch 40Amp 4MTR	TGTP31B

Spare Parts		
Part Number	Description	
A 20072	Torch Head - Hand	
1 ES19683	Electrode HD - 30-50 Amp Hafnium	
2 ES20463	Swirl Baffle - 6 Holes	
3 ES19682	Tip HD 0.96 - .038 30-50 Amp	
4 ES18204	Shield Cup	

## Topgun LT50 Plasma Torch

### Air-Cooled Plasma Cutting Torch

To Suit Topgun Spitfire Series Plasma CUT 40-M

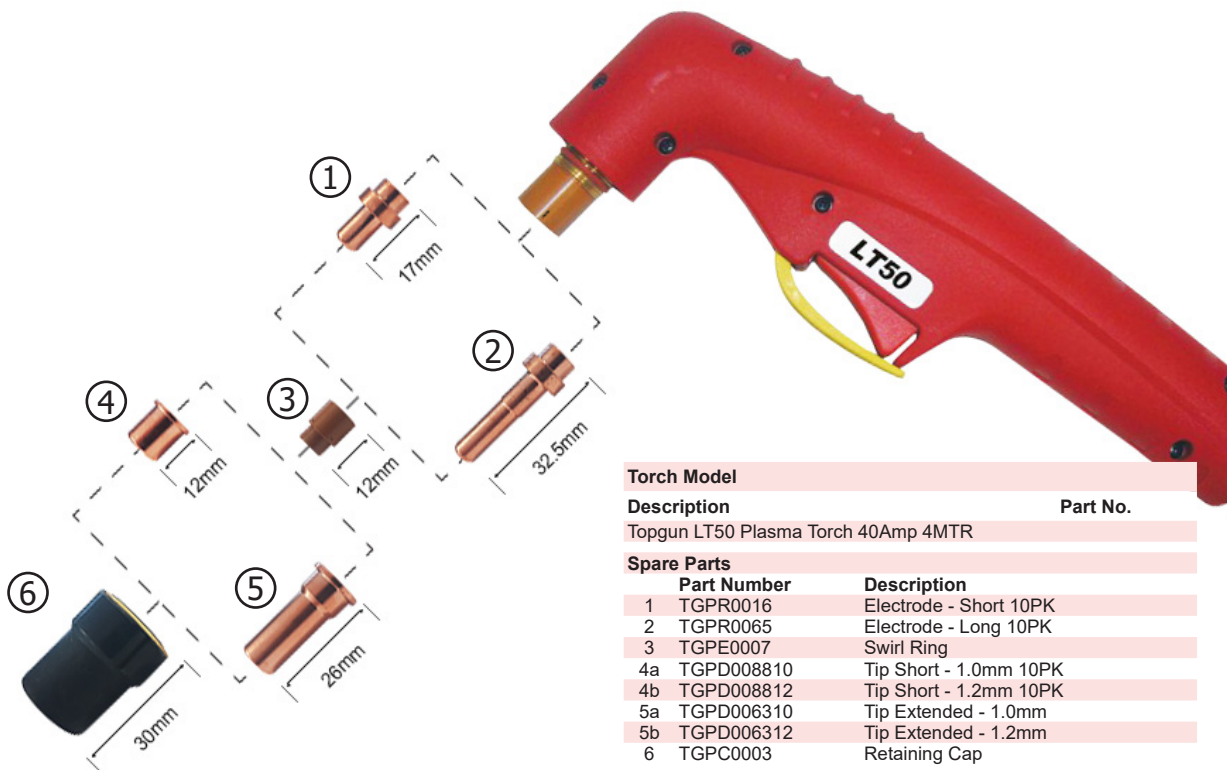

Torch Model	
Description	Part No.
Topgun LT50 Plasma Torch 40Amp 4MTR	

Spare Parts		
Part Number	Description	
1 TGPR0016	Electrode - Short 10PK	
2 TGPR0065	Electrode - Long 10PK	
3 TGPE0007	Swirl Ring	
4a TGPD008810	Tip Short - 1.0mm 10PK	
4b TGPD008812	Tip Short - 1.2mm 10PK	
5a TGPD006310	Tip Extended - 1.0mm	
5b TGPD006312	Tip Extended - 1.2mm	
6 TGPC0003	Retaining Cap	

# Topgun PT60 Plasma Torch

## Air-Cooled Plasma Cutting Torch

To Suit Topgun Spitfire Cut 42 PFC

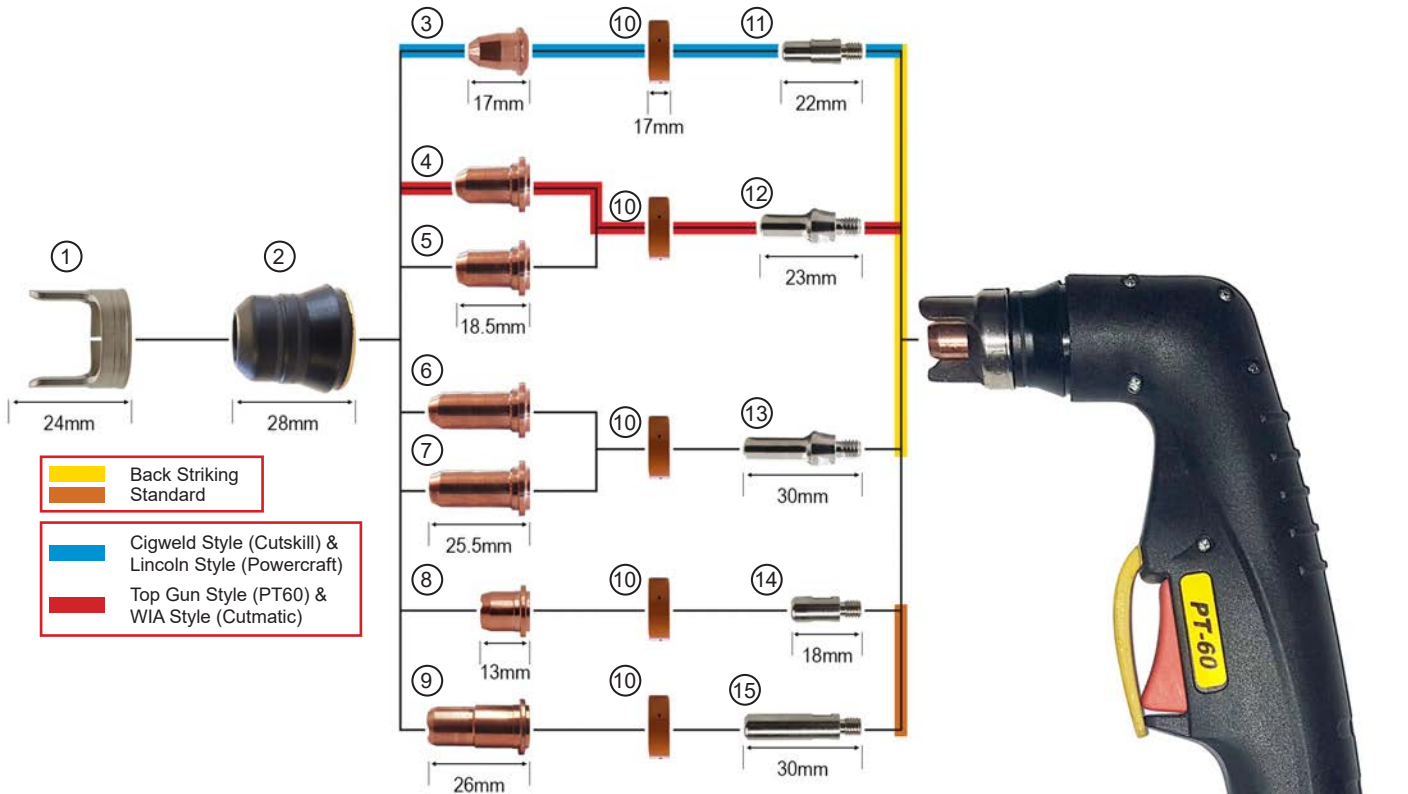

Torch Model	Part No.
Top Gun PT60 Plasma Torch 60Amp 4MTR	TGTPPT60

Spare Parts			
Part Number	Description	CIG Equivalent	Lincoln Equivalent
1 TGPCR60D	Spacer Crown	CSP337004	M25454-1
2 TGPC60389	Retaining Cap	CSP337005	M25454-2
3 TGPCPD011608	Cutting Tip 30A 0.8mm (Low Amperage)	CSP337095	M25454-3
3 TGPCPD11609PK10	Cutting Tip 40A 0.9mm (Low Amperage) 10Pk		
4 TGPC51312909PK10	Cutting Tip 60A 0.9mm 10Pk		
5 TGPC51313P11PK10	Cutting Tip 60A 1.1mm 10Pk		
6 TGPC51318L06PK10	Cutting Tip Extended 60A 0.6mm 10Pk		
6 TGPC51318L08PK10	Cutting Tip Extended 60A 0.8mm 10Pk		
7 TGPC51318L09PK10	Cutting Tip Extended 60A 0.9mm 10Pk		
7 TGPC51318L10PK10	Cutting Tip Extended 60A 1.0mm 10Pk		
8 TGPCPD10210	Cutting Tip (Trafimet Style) Short 60A 1.0mm 10Pk		
9 TFPD103	Cutting Tip (Trafimet Style) Extended 60A 0.9mm 10Pk		
10 TGPC60028	Swirl Ring	CSP337007	M25454-4
11 TGPCPR0110	Electrode - Back-striking Small	CSP337003	M25454-5
12 TGPC52582PKT10	Electrode - Back-striking Standard		
13 TGPC52583PK10	Electrode - Back-striking Extended		
14 TFPR105	Electrode - Standard Small		
15 TGPCPR0106	Electrode - Standard Small Extended		



Circle Cutting Guide to suit PT60	
Part Number	Description
TGWP41KIT	PT60 Circle Cutting Kit

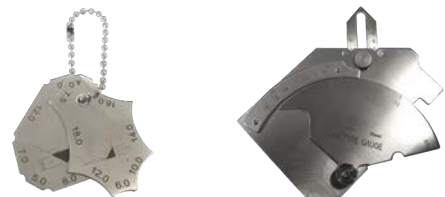

Part Number	Description
TGACGAGE	Metric Fillet Gauge
TGACGAGECAM	Cam Fillet Gauge

# Topgun XTP105 Plasma Torch

Air-Cooled Plasma Cutting Torch

To Suit Topgun Spitfire Cut 65

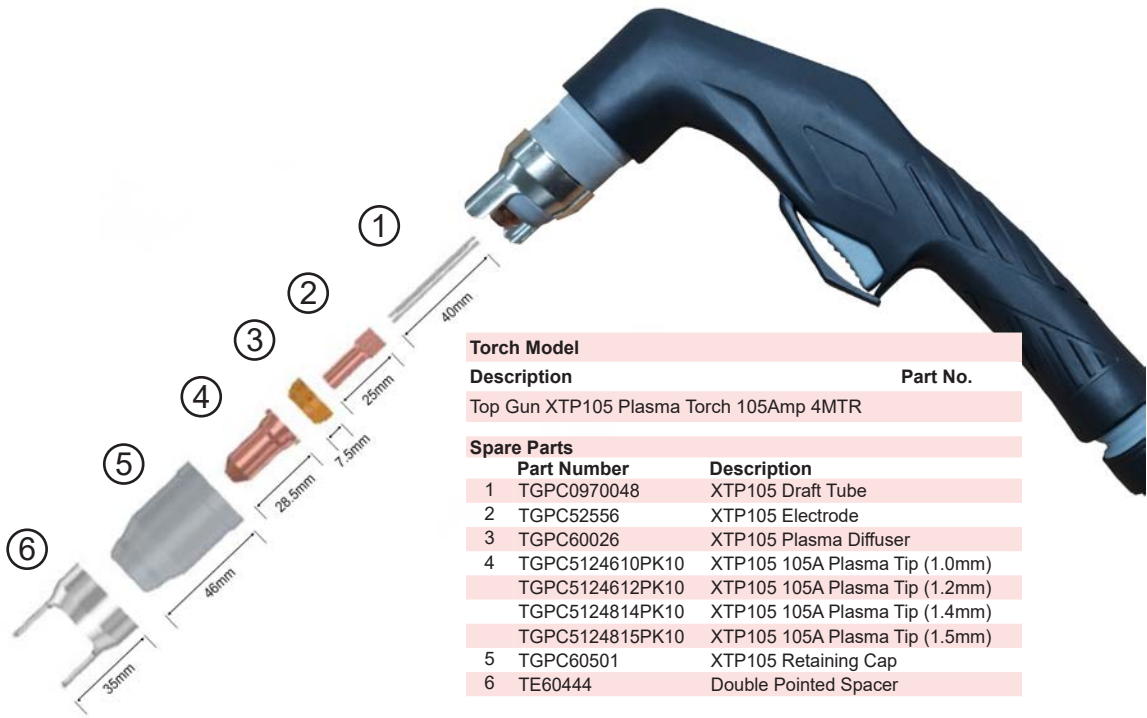

Torch Model	
Description	Part No.
Top Gun XTP105 Plasma Torch 105Amp 4MTR	
Spare Parts	
Part Number	Description
1 TGPC0970048	XTP105 Draft Tube
2 TGPC52556	XTP105 Electrode
3 TGPC60026	XTP105 Plasma Diffuser
4 TGPC5124610PK10	XTP105 105A Plasma Tip (1.0mm)
TGPC5124612PK10	XTP105 105A Plasma Tip (1.2mm)
TGPC5124814PK10	XTP105 105A Plasma Tip (1.4mm)
TGPC5124815PK10	XTP105 105A Plasma Tip (1.5mm)
5 TGPC60501	XTP105 Retaining Cap
6 TE60444	Double Pointed Spacer

# Topgun CB150 Plasma Torch

Air-Cooled Plasma Cutting Torch

To Suit Topgun Spitfire Cut 120

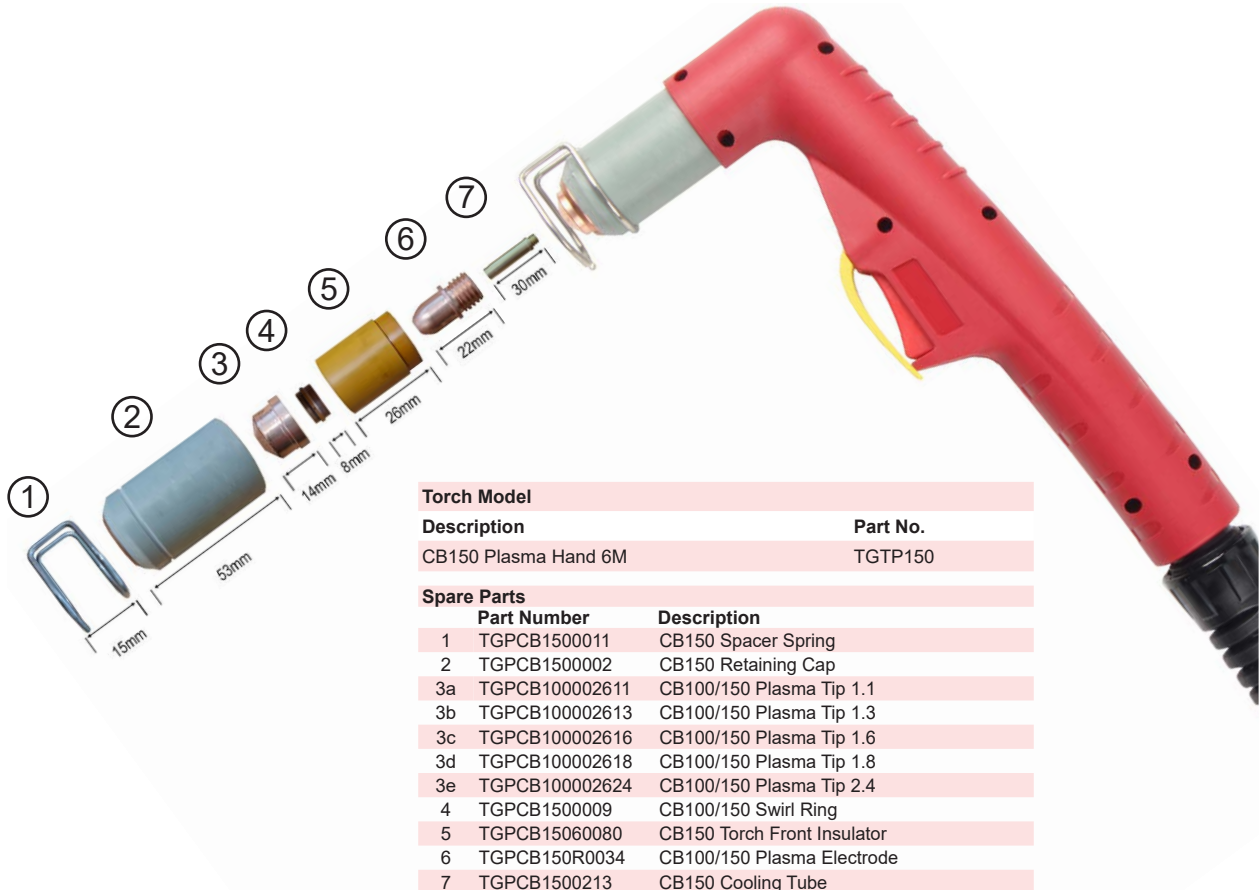

Torch Model	
Description	Part No.
CB150 Plasma Hand 6M	TGTP150
Spare Parts	
Part Number	Description
1 TGPCB1500011	CB150 Spacer Spring
2 TGPCB1500002	CB150 Retaining Cap
3a TGPCB100002611	CB100/150 Plasma Tip 1.1
3b TGPCB100002613	CB100/150 Plasma Tip 1.3
3c TGPCB100002616	CB100/150 Plasma Tip 1.6
3d TGPCB100002618	CB100/150 Plasma Tip 1.8
3e TGPCB100002624	CB100/150 Plasma Tip 2.4
4 TGPCB1500009	CB100/150 Swirl Ring
5 TGPCB15060080	CB150 Torch Front Insulator
6 TGPCB150R0034	CB100/150 Plasma Electrode
7 TGPCB1500213	CB150 Cooling Tube



# GAS EQUIPMENT



## Top Gun Oxygen/Acetylene Gas Cutting Kit

Part no.	Description
TGGKOM37	Gas Kit Oxy/Acet

### Gas Kit Includes:

1 x Heavy Duty Tool Box	3 x Cutting Nozzles 8 / 12 / 15
1 x Oxygen Regulator	1 x Heating Tip
1 x Acetylene OR LPG Regulator	1 x Oxy Goggles
1 x Cutting Handle	1 x Tip Cleaner
1 x Cutting Attachment	1 x Single Flint Lighter
1 x Mixer	2 x Flashback Arrestors (handle)
1 x 10 Metre Twin Gas Hose	2 x Flashback Arrestors (regs)
3 x Brazing Tips 3N / 5N / 6N	1 x Combination Spanner



## Top Gun Oxygen/LPG Gas Cutting Kit

Part no.	Description
TGGKOM38	Gas Kit Oxy/LPG

### Gas Kit Includes:

1 x Heavy Duty Tool Box	3 x Cutting Nozzles 8 / 12 / 15
1 x Oxygen Regulator	1 x Heating Tip
1 x Acetylene OR LPG Regulator	1 x Oxy Goggles
1 x Cutting Handle	1 x Tip Cleaner
1 x Cutting Attachment	1 x Single Flint Lighter
1 x Mixer	2 x Flashback Arrestors (handle)
1 x 10 Metre Twin Gas Hose	2 x Flashback Arrestors (regs)
3 x Brazing Tips 3N / 5N / 6N	1 x Combination Spanner



# GAS EQUIPMENT



Topgun Regulators	
Part no.	Description
1 TGRARBO	Topgun Argon Regulator with Bobbin 0-32L/M
2 TGRRB25	Topgun Flowmeter 0-25L/M
3 TGRRARGS	Topgun Argon Regulator 0-32L/M
4 TGRROXY	Topgun Oxygen Regulator 0-1000KPA
5 TGRRLPG	Topgun LPG Regulator 0-350KPA
6 TGRRACET	Topgun Acetylene Regulator 0-150KPA
7 TGRRCO2	Topgun CO2 Regulator 0-50L/M
8 GAHFYVR	Topgun Y Piece R/Hand W/Valve
9 RRCO2H	CO2 Heater 240V



Top Gun Gas Cutting Hand Piece	
Part no.	Description
TGGCA	Cutting Attachment



Top Gun Gas Cutting Handle	
Part no.	Description
TGGCH	Cutting Handle

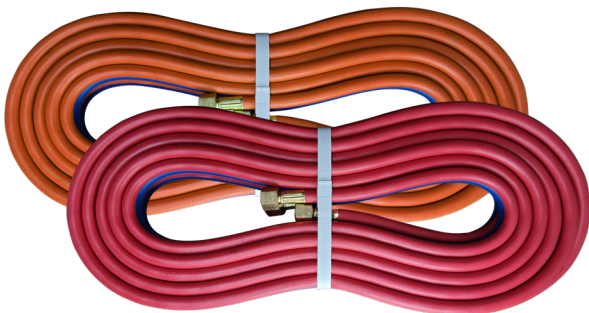

Top Gun Twin Gas Hose	
Part no.	Description
HOACE610	Acetylene 5mm Twin Hose 10 Mtr
HOACE615	Acetylene 5mm Twin Hose 15 Mtr
HOACE620	Acetylene 5mm Twin Hose 20 Mtr
HOLPG610	LPG 5mm Twin Hose 10 Mtr
HOLPG620	LPG 5mm Twin Hose 20 Mtr



Top Gun Gas Cylinder Chocks	
Part no.	Description
GABCH105	Cylinder Holder 150mm - 163mm
GABCH106	Cylinder Holder 165mm - 181mm
GABCH107	Cylinder Holder 181mm - 203mm
GABCH108	Cylinder Holder 203mm - 222mm
GABCH109	Cylinder Holder 231mm - 246mm
GABCH110	Cylinder Holder 258mm - 273mm
GABCH112	Cylinder Holder 305mm - 330mm
GABCH114	Cylinder Holder 368mm - 387mm

# GAS CUTTING CONSUMABLES

OXY / ACETYLENE

## Cutting Nozzles



Oxy/Acetylene Cutting Tips - Type 41		
Part no.	Size	Cut Size
GACN416	6	1-6mm
GACN418	18	6-10mm
GACN4110	10	10-12mm
GACN4112	12	12-20mm
GACN4115	15	20-75mm
GACN4120	20	100-125mm
GACN4124	24	150-200mm

## Gouging Nozzles

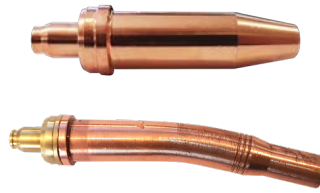

Oxy/Acetylene Gouging Tips - Type 41		
Part no.	Size	Shape
GAGNS4132	32GS	Straight
GAGNB4132	32GB	Bent
GAGNB4148	48GB	Bent

## Heating Barrels



Oxy/Acetylene Heating Tips - Type 41		
Part no.	Size	Gas
GAHNSHA1	8 x 12	Oxy/Acet
GAHNSHA2	12 x 12	Oxy/Acet

OXY / LPG

## Cutting Nozzles

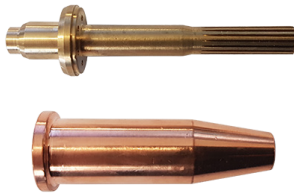

Oxy/LPG Cutting Tips - Type 44		
Part no.	Size	Cut Size
GACN446	6	3-6mm
GACN448	8	6-12mm
GACN4412	12	12-20mm
GACN4415	15	25-75mm
GACN4420	20	100-125mm
GACN4424	24	150-200mm
GACN4432	32	225-300mm

## Gouging Nozzles

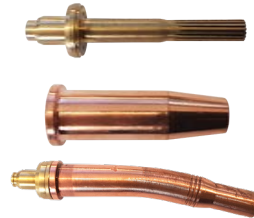

Oxy/LPG Gouging Tips - Type 44		
Part no.	Size	Shape
GAGNS4432	32GS	Straight
GAGNB4432	32GB	Bent
GAGNB4448	48GB	Bent

## Heating Tips



Oxy/LPG Heating Tips - Type 44		
Part no.	Size	Gas
TGGCHT18X12	8 x 12	Oxy/LPG
TGGCHT36X12	36 x 12	Oxy/LPG
TGGCHT48X12	48 x 12	Oxy/LPG



Gas Mixers	
Part no.	Description
TGGCM	Mixer 10mm
TGGCM13	Mixer 13mm
TGGCM13HF	Mixer 13mm High Flow

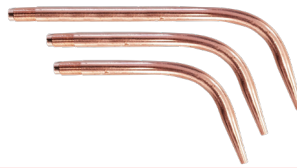

Brazing Tips Acetylene		
Part no.	Size	Description
GAWT5518	8	Tip Type 551
GAWT55110	10	Tip Type 551
GAWT55112	12	Tip Type 551
GAWT55115	15	Tip Type 551
GAWT55120	20	Tip Type 551
GAWT55126	26	Tip Type 551



Heating Barrels	
Part no.	Description
TGGCHB450S	Heating Barrel 400mm Stainless Steel Bent
TGGCHB700S	Heating Barrel 700mm Stainless Steel Bent



Single Flint Lighters	
Part no.	Description
GAFL1T	Single Flint Lighter
GAFR1	Single Flint Spares (5pk)



Tri-Flint Lighters	
Part no.	Description
GAFL3T	Triple Flint Lighter
GAFR3	Triple Flint Spares (5pk)



# ABRASIVES



## Topgun Cutting Discs

Part no.	Description
DCTG100161A	Cutting Disc 4" 1.6mm Stainless Steel (10 Pack)
DCTG125221A	Cutting Disc 5" 1mm Stainless Steel (10 Pack)
DCTG1252216A	Cutting Disc 5" 1.6mm Stainless Steel (10 Pack)

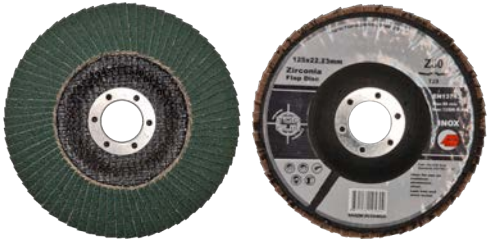

## Topgun Flap Discs

Part no.	Description
DFTG10016Z40	Flap Disc 4" 40 Grit (Zirconia) ea
DFTG10016Z60	Flap Disc 4" 60 Grit (Zirconia) ea
DFTG10016Z80	Flap Disc 4" 80 Grit (Zirconia) ea
DFTG12522Z40	Flap Disc 5" 40 Grit (Zirconia) ea
DFTG12522Z60	Flap Disc 5" 60 Grit (Zirconia) ea
DFTG12522Z80	Flap Disc 5" 80 Grit (Zirconia) ea
DFTG12522Z120	Flap Disc 5" 120 Grit (Zirconia) ea



## Topgun Grinding Discs

Part no.	Description
DGTG100166	Grinding Disc 4" 6mm 30 Grit ea
DGTG125226	Grinding Disc 5" 6mm 30 Grit ea

# SAFETY EQUIPMENT



## Top Gun Hi-Vis Welding Jacket

Part No. TGACWJHVL

### Description

High grade fire retardant (FR) cotton with cowhide leather sleeves and high visibility reflective stripes.

Sizes: L, XL, XXL, XXXL



## Top Gun Premium Welding Jacket

Part No. TGACWJLEL

### Description

Premium Cowhide leather welding jacket.

Sizes: L, XL, XXL, XXXL



## Top Gun Professional Welding Jacket

Part No. TGACWJRBL

### Description

High grade fire retardant (FR) cotton centre with premium grain leather sleeves

Sizes: L, XL, XXL, XXXL



## Top Gun Welding Apron

Part No. TGACAP1

### Description

Premium Split Cowhide Leather Welding Apron

## Top Gun Welding Sleeves

Part No. TGACSL1

### Description

High Grade Fire Retardant (FR) Cotton Centre w/ Split Cowhide Leather Sleeves.

Sizes: L, XL, XXL, XXXL



## Top Gun Welding Hoods

Part No. TGACLHOOD

### Description

Premium Split Cowhide Leather Welding Hood w/ Press Studs

Part No. TGACPBHOOD

High Grade Fire Retardant (FR) Cotton Welding Hood w/ Press Studs



## Top Gun Welding Spats

Part No. TGACSP1

### Description

Premium Split Cowhide Leather Welding Spats



## SAFETY EQUIPMENT



**Top Gun Alumized Welding Gloves**  
Part No. TGACGAL

**Description**

Alumized Leather



**Top Gun Red/Black Premium Welding Gloves**  
Part No. TGACGBRP

**Description**

Premium Leather  
Cow/Goat/Pig Skin  
Combination



**Top Gun Black/White Premium Welding Gloves**  
Part No. TGACGBWP

**Description**

Premium Leather  
Cow/Goat/Pig Skin  
Combination



**Top Gun Blue/Yellow Mig Welding Gloves**  
Part No. TGACGBY

**Description**

Split Cowhide  
Kevlar Stitched  
Blue/Yellow



**Top Gun Premium Tig Welding Gloves**  
Part No. TGACGTP

**Description**

Sheep skin/Cow hide  
Long Cuff  
Kevlar stitched



**Top Gun Red/Gold Mig Welding Gloves**  
Part No. TGACGRG

**Description**

Split Cowhide  
Kevlar Stitched  
Red/Gold



**Top Gun "Lefties" Mig Welding Gloves**  
Part No. TGACGGL

**Description**

Split Cowhide  
Kevlar Stitched  
Green "Lefties"



**Top Gun Riggers Gloves**  
Sizes S, M, L, XL, XXL  
Part No. TGACGRI

**Description**

Split Cowhide  
Gold

## WELDING CURTAINS AND BLANKETS



**Top Gun Welding Curtains**

Size	Part No.
1800mm x 1800mm Red	ACWC1818R
1800mm x 1800mm Green	ACWC1818G
1800mm x 2400mm Red	ACWC1824R
1800mm x 2400mm Green	ACWC1824G
Welding Curtain Frame 1800x1800mm	ACWCF66
Welding Curtain Frame 1800x2400mm	ACWCF68



**Top Gun Welding Blankets**

- Manufactured from 1.9mm thick 1150gsm woven heat treated E-Glass Fabric.
- Heat Treated for low smoke emissions above 220°C.
- Metal eyelets for hanging or tying down.
- Hemmed for increased fabric stability.

Size	Part No.
Welding Blanket 500°C 1800mm x 900mm	ACSB51
Welding Blanket 500°C 1800mm x 1800mm	ACSB52
Welding Blanket 700°C 1800mm x 900mm	ACSB81
Welding Blanket 700°C 1800mm x 1800mm	ACSB82

## High Definition Plasma CNC

For over 30 years, we have been industry leading suppliers of the latest CNC Plasma cutting machines the market has to offer. With our huge range of plasma cutting knowledge and consumable stock, we are able to offer both support and supply of the best CNC plasma cutting solutions in Australia.

### What is CNC Plasma Cutting?

A CNC (**Computer Numerical Control**) plasma cutter is a machine that is specifically designed to cut through electrically conductive materials by using a computer to control and direct an accelerated jet of hot plasma at the material being cut. CNC plasma cutters can cut through a wide range of different materials, including steel, aluminum, brass, and copper, and can be used for a selection of different industries.

There are various configurations available for CNC Plasma tables specific to both size and/or functionality. We help you find the solution that works best for your industry, including altering power supplies and air supplies, depending on the material thickness you are wishing to cut and cutting speeds that you require, all at an affordable price

## TRAILBLAZER



**Model:** HBTO-1530

**Working Size:** 1500mm x 3000mm

Desktop type

0-10000mm/min cutting speed

Step motor and servo motors for option:



### Technical Parameters:

<b>Working Area</b>	1500*3000mm
<b>Drive system</b>	Japan AC servo motor and Gear & step motor for optional
<b>Cutting Thickness</b>	0.5-25mm mild steel by plasma; 6-50mm mild steel by oxy-fuel cutting
<b>Cutting Speed</b>	0-10m/min
<b>Moving Speed</b>	0-10m/min
<b>Power</b>	3KW+Plasma power
<b>Input Voltage</b>	3 phase 440V, or 1 phase 220V
<b>Power Frequency</b>	50Hz, 60Hz
<b>Files Transfer</b>	USB Interface
<b>Arc</b>	Hypertherm
<b>Software</b>	FastCAM



We are suppliers of some of the highest quality laser cutting machines on the market. As warehouse automation has been proven to improve efficiency and production within many industries, we strive to stay ahead of the curve by not only offering high-end equipment, but offering a wealth of expertise and knowledge allowing us to provide the optimum solution for your automation needs.

## SF3015H



**3015H 3KW Laser Cutter - 3000m x 1500mm**

### Technical Parameters

Model	SF3015H
Working size	3000mm*1500mm
X-axis travel	3000mm
Y -axis travel	1500mm
Z -axis travel	220mm
Laser power	3000W
X/Y Axis positioning accuracy	±0.05mm/m
X/Y Axis repeated positioning	±0.02mm
Maximum velocity of movement	100m/min
Machine weight	4888KG
Outline size	4735*2720*2100



**PROUDLY STOCKED BY**